



# City of Killeen

## Agenda City Council Workshop

---

Tuesday, May 19, 2015

5:00 PM

Killeen City Hall  
101 North College Street  
Main Conference Room

---

### IMMEDIATELY FOLLOWING SPECIAL CITY COUNCIL MEETING

#### Items for Discussion at Workshop

- [DS-15-049](#) Discuss Agenda Items and Land Use Cases
- [DS-15-050](#) Receive a Briefing on City Council Rules of Procedure and Protocol
- [DS-15-051](#) Receive a Briefing on Exempt Parking at the Airport

#### Items for Regular City Council Meeting of May 26, 2015

#### Minutes

- [MN-15-004](#) Consider minutes of Regular City Council meeting of May 12, 2015.  
*Attachments:* [Minutes](#)
- [MN-15-005](#) Consider minutes of Special City Council meeting of May 19, 2015.  
*Attachments:* [Minutes](#)

#### Resolutions

- [RS-15-015A](#) Consider a memorandum/resolution authorizing the City Manager to enter into an advance funding agreement with the Texas Department of Transportation for the Gateway Monument (on SH 195 at the southern city limits) project.  
*Attachments:* [Council Memorandum Agreement](#)  
[Cost Estimate](#)
- [RS-15-015B](#) Consider a memorandum/resolution to authorize the City Manager to execute a landscape maintenance agreement for the Gateway Monument project with the Texas Department of Transportation.

**Attachments:** [Council Memorandum](#)

[TxDOT Letter](#)

[Agreement](#)

[Attachment-A](#)

[RS-15-016](#) Consider a memorandum/resolution authorizing Change Order No. 37 with James Construction Group, LLC to the US 190/FM 2410/Rosewood Drive project.

**Attachments:** [Council Memorandum](#)

[Change Order](#)

[RS-15-017](#) Consider a memorandum/resolution authorizing Change Order No. 38 with James Construction Group, LLC to the US 190/FM 2410/Rosewood Drive project.

**Attachments:** [Council Memorandum](#)

[Change Order](#)

[RS-15-018](#) Consider a memorandum/resolution authorizing the award of a professional services agreement with Kasberg, Patrick & Associates, LP to design the Onion Road Area Water Line Project.

**Attachments:** [Council Memorandum](#)

[Agreement](#)

[RS-15-019](#) Consider a memorandum/resolution authorizing a lease agreement with C&M Golf and Grounds Equipment for Parks and Recreation mowing equipment utilizing the TASB Buy Board.

**Attachments:** [Council Memorandum](#)

[Equipment Lease](#)

[RS-15-020](#) Consider a memorandum/resolution to authorize the award of a professional services contract to Halff & Associates to prepare a Parks Master Plan.

**Attachments:** [Council Memorandum](#)

[Agreement](#)

[Scope of Services](#)

[RS-15-021](#) Consider a memorandum/resolution authorizing the lease of a dozer for the Solid Waste Transfer Station.

**Attachments:** [Council Memorandum](#)

[WPI Quote](#)

[Dozer Picture and Standard Equipment List](#)

[RS-15-022](#) Consider a memorandum/resolution authorizing the donation of obsolete City property to the Bell County Information Technology Department.

**Attachments:** [Council Memorandum](#)  
[Property Donation](#)

[RS-15-023](#) Consider a memorandum/resolution approving the investment report for the quarter that ended March 31, 2015.

**Attachments:** [Council Memorandum](#)  
[Quarterly Report](#)

## Ordinances

[OR-15-009](#) Consider an ordinance approving a negotiated settlement between the Atmos Cities Steering Committee and Atmos Energy, Corp., Mid-Tex Division, regarding the 2014 and 2015 Rate Review Mechanism Filings.

**Attachments:** [Council Memorandum](#)  
[Ordinance](#)  
[Attachments to Ordinance](#)

## Public Hearings

[PH-15-021A](#) Consider a memorandum/resolution to purchase mechanic toolkits for Fleet Services.

**Attachments:** [Council Memorandum](#)  
[Quote](#)  
[Tools](#)

[PH-15-021B](#) HOLD a public hearing and consider an ordinance amending the FY 2015 Annual Budget and Plan of Municipal Services of the City of Killeen by increasing a Water and Sewer Fund account by \$152,749 to fund the purchase of 14 tool kits for Fleet Services.

**Attachments:** [Council Memorandum](#)  
[Ordinance](#)

## Adjournment

*I certify that the above notice of meeting was posted on the Internet and on the bulletin boards at Killeen City Hall and at the Killeen Police Department on or before 5:00 p.m. on May 15, 2015.*

---

*Dianna Barker, City Secretary*

*The public is hereby informed that notices for City of Killeen meetings will no longer distinguish between matters to be discussed in open or closed session of a meeting. This practice is in accordance with rulings by the Texas Attorney General that, under the Texas Open Meetings Act, the City Council may convene a closed session to discuss any matter listed on the agenda, without prior or further notice, if the matter is one that the Open Meetings Act allows to be discussed in a closed session..*

*This meeting is being conducted in accordance with the Texas Open Meetings Law [V.T.C.A., Government Code, § 551.001 et seq.]. This meeting is being conducted in accordance with the Americans with Disabilities Act [42 USC 12101 (1991)]. The facility is wheelchair accessible and handicap parking is available. Requests for sign interpretive services are available upon requests received at least 48 hours prior to the meeting. To make arrangements for those services, please call 254-501-7700, City Manager's Office, or TDD 1-800-734-2989.*

## **Future Workshop Items**

*The following items have been scheduled for workshop discussion on the dates shown. The final scheduling of these items is dependent upon the presenters/interested parties being available on the dates projected.*

## **Notice of Meetings**

*The Mayor and/or City Council have been invited to attend and/or participate in the following meetings/conferences/events. Although a quorum of the members of the City Council may or may not be available to attend this meeting, this notice is being posted to meet the requirements of the Texas Open Meetings Act and subsequent opinions of the Texas Attorney General's Office.*

- KISD Starmakers Banquet, May 19, 2015, 6:00 p.m., Killeen Civic and Conference Center*
- 2015 Bell County Police Officers Memorial, May 21, 2015, 10:00 a.m., Killeen Police Headquarters*
- Army Birthday Celebration, June 13, 2015, 9:00 a.m., Downtown Killeen*
- Juneteenth Festivities, June 18-20, 2015, Killeen Arts and Activity Center - Downtown Killeen*

**Dedicated Service -- Every Day, for Everyone!**





# City of Killeen

## Legislation Details

---

**File #:** DS-15-049    **Version:** 1    **Name:** Discuss Agenda Items and Land Use Cases  
**Type:** Discussion Items    **Status:** Discussion Items  
**File created:** 5/1/2015    **In control:** City Council Workshop  
**On agenda:** 5/19/2015    **Final action:**  
**Title:** Discuss Agenda Items and Land Use Cases  
**Sponsors:** City Manager Department  
**Indexes:**  
**Code sections:**  
**Attachments:**

Date	Ver.	Action By	Action	Result
------	------	-----------	--------	--------



# City of Killeen

## Legislation Details

---

**File #:** DS-15-050    **Version:** 1    **Name:** Discuss City Council Rules of Procedure and Protocol  
**Type:** Discussion Items    **Status:** Discussion Items  
**File created:** 5/8/2015    **In control:** City Council Workshop  
**On agenda:** 5/19/2015    **Final action:**  
**Title:** Receive a Briefing on City Council Rules of Procedure and Protocol  
**Sponsors:** City Attorney Department, City Manager Department  
**Indexes:**  
**Code sections:**  
**Attachments:**

Date	Ver.	Action By	Action	Result
------	------	-----------	--------	--------



# City of Killeen

## Legislation Details

---

**File #:** DS-15-051    **Version:** 1    **Name:** Receive a Briefing on Exempt Parking at the Airport  
**Type:** Discussion Items    **Status:** Discussion Items  
**File created:** 5/7/2015    **In control:** City Council Workshop  
**On agenda:** 5/19/2015    **Final action:**  
**Title:** Receive a Briefing on Exempt Parking at the Airport  
**Sponsors:** Aviation Department  
**Indexes:**  
**Code sections:**  
**Attachments:**

Date	Ver.	Action By	Action	Result
------	------	-----------	--------	--------



# City of Killeen

## Legislation Details

---

**File #:** MN-15-004    **Version:** 1    **Name:** Minutes of Regular City Council Meeting of May 12, 2015  
**Type:** Minutes    **Status:** Minutes  
**File created:** 5/1/2015    **In control:** City Council Workshop  
**On agenda:** 5/19/2015    **Final action:**  
**Title:** Consider minutes of Regular City Council meeting of May 12, 2015.  
**Sponsors:** City Secretary  
**Indexes:**  
**Code sections:**  
**Attachments:** [Minutes](#)

Date	Ver.	Action By	Action	Result
------	------	-----------	--------	--------

**City of Killeen**  
Regular City Council Meeting  
Killeen City Hall  
May 12, 2015 at 5:00 p.m.

Presiding: Mayor Scott Cospers

Attending: Council members Terry Clark, Juan Rivera, Wayne Gilmore, Steve Harris, Jonathan Okray, and Jose Segarra

Absent: Mayor Pro-Tem Elizabeth Blackstone

Also attending were City Manager Glenn Morrison, Deputy City Attorney Traci Briggs, City Secretary Dianna Barker, and Sergeant-at-Arms McDaniel.

Dr. Campbell gave the invocation, and Councilmember Gilmore led everyone in the pledge of allegiance.

**Approval of Agenda**

*Motion was made by Councilmember Gilmore to approve the agenda as written. Motion seconded by Councilmember Rivera. The motion carried unanimously.*

**Minutes**

*Motion was made by Councilmember Gilmore to approve the minutes of the April 28th Regular City Council Meeting. Motion was seconded by Councilmember Okray. Motion carried unanimously.*

**Resolutions**

**RS-15-011** Consider a memorandum/resolution approving the use of Killeen Arts Commission funding for the 240th Army Birthday Celebration in Downtown Killeen.

**Staff comments:** Hilary Shine

Staff recommends that City Council approve the use of \$10,000 from account #214-0000-531.55-43 to host the Army Birthday Celebration June 13, 2015, which will promote the arts, celebrate Fort Hood and the Army and encourage Downtown revitalization.

*Motion was made by Councilmember Rivera to approve RS-011. Motion was seconded by Councilmember Segarra. Motion carried unanimously.*

**RS-15-012** Consider a memorandum/resolution authorizing the award of Bid No. 15-14 for street materials, rock, and top soil.

**Staff comments:** Scott Osburn

City staff recommends that the City Council award purchase contracts to APAC Wheeler and Lonestar Grading for the purchase of various street materials, rock, and top soil; authorize the City Manager to enter into a contract with the same, including the proposed extensions described; and finally, authorize the City Manager to execute any and all change orders in the amounts established by state and local law.

*Motion was made by Councilmember Gilmore to approve RS-012. Motion was seconded by Councilmember Clark. Motion carried unanimously.*

**RS-15-013** Consider a memorandum/resolution confirming the City Manager's annual evaluation and pay increase.

**Staff comments:** Mayor Cospers

Recommend City Council confirms the 2% increase to the City Manager's annual salary.

*Motion was made by Councilmember Rivera to approve RS-013. Motion was seconded by Councilmember Segarra. Motion expired. No vote called for.*

*Motion was made by Councilmember Okray to consider the evaluation and pay increase separately. Motion was made by Councilmember Clark. Motion carried unanimously.*

*Motion was made by Councilmember Okray to approve the evaluation of the city manager. Motion was seconded by Councilmember Harris. Motion carried unanimously.*

*Motion was made by Councilmember Gilmore to approve a 2% pay increase for the city manager. Motion was seconded by Councilmember Segarra. Motion carried 4 to 2 with Councilmember Okray and Councilmember Harris opposing.*

### **Public Hearings**

**PH-15-019** HOLD a public hearing and consider an ordinance requested by Eddie W. Levell and Gracie E. Levell (Case #Z15-08) to rezone 1.625 acres from "R-1" (Single-Family Residential District) to "B-5" (Business District), being part of the G.W. Farris Survey, Abstract No. 306. The property is located adjacent to, and north of, Tabernacle of Praise Replat and west of Extreme Addition, Killeen, Texas.

The City Secretary read the caption of the ordinance.

**AN ORDINANCE AMENDING THE ZONING ORDINANCE OF THE CITY OF KILLEEN BY CHANGING THE ZONING OF CERTAIN PROPERTY OUT OF THE CITY OF KILLEEN, BELL COUNTY, TEXAS, FROM R-1 (SINGLE-FAMILY RESIDENTIAL DISTRICT) TO B-5 (BUSINESS DISTRICT); PROVIDING A SAVINGS CLAUSE; PROVIDING FOR THE REPEAL OF CONFLICTING PROVISIONS; PROVIDING FOR AN EFFECTIVE DATE.**

**Staff comments:** Tony McIlwain

Staff notified nine (9) surrounding property owners within the 200 foot notification area. Two (2) responses were received for approval of the rezoning request from William D. Morris who owns 2 properties just to the east of the subject property. One (1) response was received in opposition to the rezoning request from Sandra Cloud who owns 4900 Trimmier Rd. After hearing comments from the realtor and agent regarding the intended use of the subject property, the Planning and Zoning Commission recommended approval of "B-5" (Business District) by a vote of 5 to 1.

Mayor Cospers opened the public hearing.

Michelle Lee, 2901 E. Stan Schlueter Loop - was present to answer questions regarding rezoning.

David Barr, David Barr Properties, 3800 Trimmier - explained the reasons for the client purchasing property.

With no one else appearing the public hearing was closed.

*Motion was made by Councilmember Gilmore to approve PH-019. Motion was seconded by Councilmember Okray. Motion carried unanimously.*

**PH-15-020** HOLD a public hearing and consider an ordinance requested by FAI Killeen Partners, Ltd. (Case #Z15-06) to rezone approximately 63.20 acres from "M-1" (Manufacturing District) to "B-5" (Business District), being out of the the James C. McKee Survey, Abstract No. 992 and out of the Robert Cunningham Survey, Abstract No. 158. The property is located north of the intersection of Stan Schlueter Loop (FM 3470) and Martin Luther King Jr. Boulevard (FM 2410), Killeen, Texas.

The City Secretary read the caption of the ordinance.

**AN ORDINANCE AMENDING THE ZONING ORDINANCE OF THE CITY OF KILLEEN BY CHANGING THE ZONING OF CERTAIN PROPERTY OUT OF THE CITY OF KILLEEN, BELL COUNTY, TEXAS, FROM M-1 (MANUFACTURING DISTRICT) TO B-5 (BUSINESS DISTRICT); PROVIDING A SAVINGS CLAUSE; PROVIDING FOR THE REPEAL OF CONFLICTING PROVISIONS; PROVIDING FOR AN EFFECTIVE DATE.**

**Staff comments:** Tony McIlwain

Staff notified 13 surrounding property owners within the 200' notification area. Staff has received one response of support from Robert Fogle, the owner of 5101 Martin Luther King Jr. Boulevard, Killeen, Texas. The Planning and Zoning Commission recommended approval of "B-5" (Business District) by a vote of 6 to 0.

Mayor Cospoer opened the public hearing.

Gary Davis, 2700 Barton Creek Blvd, Austin TX - gave a brief description of the project. With no one else appearing the public hearing was closed.

*Motion was made by Councilmember Clark to approve PH-020. Motion was seconded by Councilmember Rivera. Motion carried unanimously.*

### **Adjournment**

With no further business, upon motion being made by Councilmember Okray, seconded by Councilmember Gilmore, and unanimously approved, the meeting was adjourned at 5:29 p.m.



# City of Killeen

## Legislation Details

---

**File #:** MN-15-005    **Version:** 1    **Name:** Minutes of Special City Council Meeting of May 19, 2015  
**Type:** Minutes    **Status:** Minutes  
**File created:** 5/1/2015    **In control:** City Council Workshop  
**On agenda:** 5/19/2015    **Final action:**  
**Title:** Consider minutes of Special City Council meeting of May 19, 2015.  
**Sponsors:** City Secretary  
**Indexes:**  
**Code sections:**  
**Attachments:** [Minutes](#)

Date	Ver.	Action By	Action	Result
------	------	-----------	--------	--------



**City of Killeen**  
Special City Council Meeting  
Killeen City Hall  
May 19, 2015 at 5:00 p.m.

Minutes of the Special City Council meeting will be provided in the agenda packet for May 26, 2015.



# City of Killeen

## Legislation Details

---

**File #:** RS-15-015A    **Version:** 1    **Name:** Landscaping - Gateway Monument at SH 195  
**Type:** Resolution    **Status:** Resolutions  
**File created:** 4/17/2015    **In control:** City Council Workshop  
**On agenda:** 5/19/2015    **Final action:**  
**Title:** Consider a memorandum/resolution authorizing the City Manager to enter into an advance funding agreement with the Texas Department of Transportation for the Gateway Monument (on SH 195 at the southern city limits) project.  
**Sponsors:** Public Works Department, Transportation Division  
**Indexes:**  
**Code sections:**  
**Attachments:** [Council Memorandum Agreement](#)  
[Cost Estimate](#)

Date	Ver.	Action By	Action	Result
------	------	-----------	--------	--------

## CITY COUNCIL MEMORANDUM

### AGENDA ITEM

**AUTHORIZE THE CITY MANAGER TO ENTER INTO AN ADVANCE FUNDING AGREEMENT WITH THE TEXAS DEPARTMENT OF TRANSPORTATION FOR THE GATEWAY MONUMENT (ON SH 195 AT THE SOUTHERN CITY LIMITS) PROJECT**

### ORIGINATING DEPARTMENT

**PUBLIC WORKS - TRANSPORTATION DIVISION**

### BACKGROUND INFORMATION

Keep Texas Beautiful, in partnership with the Texas Department of Transportation (TxDOT), has awarded the prestigious Governor's Community Achievement Awards (GCAA) to ten Texas communities having the best grassroots environmental programs in the state each year. This award annually endows Texas communities with a share of landscaping prize money to be used in the construction of a beautification project within the winning community. The projects are completed on selected state rights-of-way and conform to both the winning city's aesthetic expectations and stringent standards of safety, design, and maintenance laid out by TxDOT.

Keep Killeen Beautiful (KKB), a committee of Killeen Volunteers, Inc., has been a promoter of educating citizens and encouraging them to invest in the health and beauty of their surroundings. In 2011, KKB presented a GCAA application and was awarded a \$290,000 landscape award.

The Volunteer Services Division staff, as a representative for KKB, approached the Transportation Division staff for ideas on a project to expend the award. A Gateway Monument project with landscaping on SH 195 at the southern city limits was devised and the Transportation Division proposed to provide design services. On April 23, 2013, the City Manager signed a contract with Walker Partners to design the SH 195 Landscaping - Gateway Monument. Design services are primarily complete. The scope of this project shall offer a means for the local government to fund and the State to manage the construction of a gateway monument within the State's roadway border area of SH 195 at the south city limits of Killeen.

### DISCUSSION/CONCLUSION

TxDOT requires the City of Killeen to enter into an advanced funding agreement (AFA), which is attached hereto and incorporated herein. By entering into this agreement with TxDOT, the City agrees the project will include funding through the State Governor's GCAA program to a maximum amount of \$290,000 and that the City of Killeen is responsible for 100% of all estimated construction costs above that amount and any overruns associated with project construction. The Engineer's Opinion of Probable Cost is \$230,204.70.

## **FISCAL IMPACT**

The total estimated fiscal impact associated with this project is \$230,204.70, which will be funded by the maximum award of \$290,000 to Keep Killeen Beautiful. Since the GCAA funds are managed and distributed by TxDOT, there will be no initial payment from the City to TxDOT required to be sent with the executed advanced funding agreement. In the event that the construction costs exceed the \$290,000 award, funds are available in the PTF SH 195/201 Interchange General Obligation Bond, account number 342-3490-800.58-34.

## **RECOMMENDATION**

City staff recommends that the City Council authorize the City Manager to enter into an advance funding agreement with the Texas Department of Transportation for the Gateway Monument project.

**ORIGINAL**

STATE OF TEXAS       §  
COUNTY OF TRAVIS   §

**ADVANCE FUNDING AGREEMENT FOR VOLUNTARY  
LOCAL GOVERNMENT CONTRIBUTIONS  
TO TRANSPORTATION IMPROVEMENT  
PROJECTS WITH NO REQUIRED MATCH**

**THIS AGREEMENT** is made by and between the State of Texas, acting by and through the Texas Department of Transportation, called the "State", and the City of Killeen, acting by and through its duly authorized officials, called the "Local Government."

**WITNESSETH**

**WHEREAS**, Transportation Code, Chapters 201, 221, and 361, authorize the State to lay out, construct, maintain, and operate a system of streets, roads, and highways that comprise the State Highway System; and,

**WHEREAS**, Government Code, Chapter 791, and Transportation Code, §201.209 and Chapter 221, authorize the State to contract with municipalities and political subdivisions; and,

**WHEREAS**, Commission Minute Order Number 114125 authorizes the State to undertake and complete a highway improvement generally described as the on-system construction of scenic enhancements; and,

**WHEREAS**, the Local Government has requested that the State allow the Local Government to participate in said improvement by funding that portion of the improvement described as landscape enhancements consisting of a gateway monument, called the "Project"; and,

**WHEREAS**, the State has determined that such participation is in the best interest of the citizens of the State;

**NOW, THEREFORE**, in consideration of the premises and of the mutual covenants and agreements of the parties hereto, to be by them respectively kept and performed as hereinafter set forth, the State and the Local Government do agree as follows:

**AGREEMENT**

**1. Time Period Covered**

This agreement becomes effective when signed by the last party whose signing makes the agreement fully executed, and the State and the Local Government will consider it to be in full force and effect until the Project described in this agreement has been completed and accepted by all parties or unless terminated, as provided for by this agreement.



## **2. Project Funding and Work Responsibilities**

- A.** The State will authorize the performance of only those Project items of work which the Local Government has requested and has agreed to pay for as described in Attachment A, Payment Provision and Work Responsibilities which is attached to and made a part of this contract. In addition to identifying those items of work paid for by payments to the State, Attachment A, Payment Provision and Work Responsibilities, also specifies those Project items of work that are the responsibility of the Local Government and will be carried out and completed by the Local Government, at no cost to the State.
- B.** At least sixty (60) days prior to the date set for receipt of the construction bids, the Local Government shall remit its remaining financial share for the State's estimated construction oversight and construction costs.
- C.** In the event that the State determines that additional funding by the Local Government is required at any time during the Project, the State will notify the Local Government in writing. The Local Government shall make payment to the State within thirty (30) days from receipt of the State's written notification.
- D.** Whenever funds are paid by the Local Government to the State under this agreement, the Local Government shall remit a check or warrant made payable to the "Texas Department of Transportation Trust Fund." The check or warrant shall be deposited by the State in an escrow account to be managed by the State. Funds in the escrow account may only be applied by the State to the Project. If, after final Project accounting, excess funds remain in the escrow account, those funds may be applied by the State to the Local Government's contractual obligations to the State under another advance funding agreement with approval by appropriate personnel of the Local Government.

## **3. Right of Access**

If the Local Government is the owner of any part of the Project site, the Local Government shall permit the State or its authorized representative access to the site to perform any activities required to execute the work.

## **4. Adjustments Outside the Project Site**

The Local Government will provide for all necessary right of way and utility adjustments needed for performance of the work on sites not owned or to be acquired by the State.

## **5. Responsibilities of the Parties**

The State and the Local Government agree that neither party is an agent, servant, or employee of the other party and each party agrees it is responsible for its individual acts and deeds as well as the acts and deeds of its contractors, employees, representatives, and agents.

## **6. Document and Information Exchange**

The Local Government agrees to electronically deliver to the State all general notes, specifications, contract provision requirements and related documentation in a Microsoft® Word or similar document. If requested by the State, the Local Government will use the State's document template. The Local Government shall also provide a detailed construction time estimate including types of activities and month in the format required by the State. This requirement applies whether the local government creates the documents with its own forces or

by hiring a consultant or professional provider. At the request of the State, the Local Government shall submit any information required by the State in the format directed by the State.

**7. Interest**

The State will not pay interest on funds provided by the Local Government. Funds provided by the Local Government will be deposited into, and retained in, the State Treasury.

**8. Inspection and Conduct of Work**

Unless otherwise specifically stated in Attachment A, Payment Provision and Work Responsibilities, to this contract, the State will supervise and inspect all work performed hereunder and provide such engineering inspection and testing services as may be required to ensure that the Project is accomplished in accordance with the approved plans and specifications. All correspondence and instructions to the contractor performing the work will be the sole responsibility of the State. Unless otherwise specifically stated in Attachment A to this contract, all work will be performed in accordance with the Standard Specifications for Construction and Maintenance of Highways, Streets, and Bridges adopted by the State and incorporated in this agreement by reference, or special specifications approved by the State.

**9. Increased Costs**

- A.** If the Local Government's financial responsibility is a specified percentage as reflected in Attachment A, Payment Provision and Work Responsibilities, and changed site conditions are discovered that result in the Local Government's funding being insufficient to cover the State's cost for performance of the Local Government's requested work, the Local Government will pay to the State the additional funds necessary to cover the additional cost. The State shall send the Local Government a written notification stating the amount of additional funding needed and stating the reasons for the additional funds. The Local Government shall pay the funds to the State within thirty (30) days of the written notification, unless otherwise agreed to by the parties to this agreement. Should the Local Government fail to pay the additional funds, this agreement shall be mutually terminated in accordance with Article 11 – Termination.
- B.** If any existing or future local ordinances, commissioners court orders, rules, policies, or other directives, including but not limited to outdoor advertising billboards and storm water drainage facility requirements, are more restrictive than State or Federal Regulations, or if any other locally proposed changes, including but not limited to plats or replats, result in increased cost to the department for a highway improvement project, then any increased costs associated with the ordinances or changes will be paid by the Local Government. The cost of providing right of way acquired by the State shall mean the total expenses in acquiring the property interests either through negotiations or eminent domain proceedings, including but not limited to expenses related to relocation, removal, and adjustment of eligible utilities.



**10. Maintenance**

Upon completion of the Project, the State will assume responsibility for the maintenance of the completed Project unless otherwise specified in Attachment A to this agreement.

**11. Termination**

- A. This agreement may be terminated in the following manner:
  - 1. By mutual written agreement and consent of both parties;
  - 2. By either party upon the failure of the other party to fulfill the obligations set forth in this agreement; or
  - 3. By the State if it determines that the performance of the Project is not in the best interest of the State.
- B. If the agreement is terminated in accordance with the above provisions, the Local Government will be responsible for the payment of Project costs incurred by the State on behalf of the Local Government up to the time of termination.
- C. Upon completion of the Project, the State will perform an audit of the Project costs. Any funds due to the Local Government, the State, or the Federal Government will be promptly paid by the owing party.

**12. Notices**

All notices to either party by the other required under this agreement shall be delivered personally or sent by certified or U.S. mail, postage prepaid or sent by electronic mail, (electronic notice being permitted to the extent permitted by law but only after a separate written consent of the parties), addressed to such party at the following addresses:

<b>Local Government:</b>	<b>State:</b>
City Manager	Director of Contract Services Office
City of Killeen	Texas Department of Transportation
P.O. Box 1329	125 E. 11 <sup>th</sup> Street
Killeen, Texas 76540	Austin, Texas 78701

All notices shall be deemed given on the date so delivered or so deposited in the mail, unless otherwise provided in this agreement. Either party may change the above address by sending written notice of the change to the other party. Either party may request in writing that such notices shall be delivered personally or by certified U.S. mail and such request shall be honored and carried out by the other party.



**13. Sole Agreement**

In the event the terms of the agreement are in conflict with the provisions of any other existing agreements between the Local Government and the State, the latest agreement shall take precedence over the other agreements in matters related to the Project.

**14. Successors and Assigns**

The State and the Local Government each binds itself, its successors, executors, assigns, and administrators to the other party to this agreement and to the successors, executors, assigns, and administrators of such other party in respect to all covenants of this agreement.

**15. Amendments**

By mutual written consent of the parties, this agreement may be amended prior to its expiration.

**16. State Auditor**

The state auditor may conduct an audit or investigation of any entity receiving funds from the State directly under the contract or indirectly through a subcontract under the contract. Acceptance of funds directly under the contract or indirectly through a subcontract under this contract acts as acceptance of the authority of the state auditor, under the direction of the legislative audit committee, to conduct an audit or investigation in connection with those funds. An entity that is the subject of an audit or investigation must provide the state auditor with access to any information the state auditor considers relevant to the investigation or audit.

**17. Insurance**

If this agreement authorizes the Local Government or its contractor to perform any work on State right of way, before beginning work the entity performing the work shall provide the State with a fully executed copy of the State's Form 1560 Certificate of Insurance verifying the existence of coverage in the amounts and types specified on the Certificate of Insurance for all persons and entities working on State right of way. This coverage shall be maintained until all work on the State right of way is complete. If coverage is not maintained, all work on State right of way shall cease immediately and the State may recover damages and all costs of completing the work.

**18. Signatory Warranty**

Each signatory warrants that the signatory has necessary authority to execute this agreement on behalf of the entity represented.

**THIS AGREEMENT IS EXECUTED** by the State and the Local Government in duplicate.

**THE LOCAL GOVERNMENT**

\_\_\_\_\_  
Signature

\_\_\_\_\_  
Typed or Printed Name

\_\_\_\_\_  
Title

\_\_\_\_\_  
Date

**THE STATE OF TEXAS**

\_\_\_\_\_  
District Engineer

\_\_\_\_\_  
Date

## **ATTACHMENT A PAYMENT PROVISION AND WORK RESPONSIBILITIES**

### **Description of the Work Items**

The scope of this project shall offer a means for the Local Government to fund and State to manage the construction of a gateway monument within the State's roadway border area of SH 195 @ the south city limits of Killeen. This work will enhance the movement of traffic in this rapidly growing area of Bell County.

### **Actual Costs Agreement**

The project will include funding through the State's Governor's Community Achievement Award (Landscape Incentive) Award program to a maximum amount of \$290,000. The Local Government is responsible for 100% of all estimated construction costs above that amount and any overruns associated with project construction.

Preliminary estimates indicate estimated construction costs equaling \$290,000.

Any direct or indirect cost charges associated with the State's participation in the Project will be the responsibility of the State.

### **Schedule of Payments**

The Local Government will submit any required payments as outlined in Article 2 of the agreement.

### **Maintenance**

The Local Government will maintain the project area that is within the State's ROW upon completion of the project as described in the Landscape Maintenance Agreement.

*"Opinion of Probable Cost"*  
**KILLEEN GATEWAY MONUMENT @ S.H. 195**

*Killeen, Texas*

Prepared by David C. Baldwin Inc. /Landscape Architecture and Planning  
 February 5, 2015

Item	Unit	Quantity	Unit Cost	Total	
0500 6001	Mobilization	L.S.	1	\$3,000.00	\$3,000.00
0502 6001	Barricades, Signs, & Traffic Handling	Month	2	\$1,500.00	\$3,000.00
0110 6001	Excavation and Grading	C.Y.	193	\$40.00	\$7,720.00
0160 6003	Furnishing & Placing 4" Topsoil - all beds & Colorado River Rock areas	S.Y.	950	\$5.00	\$4,750.00
1002 6002	LS Amenity (TY 1) - Monument Tower	Each	1	\$25,000.00	\$25,000.00
1002 6002	LS Amenity (TY 1) - Sign Footing	L.F.	46	\$60.00	\$2,760.00
1002 6002	LS Amenity (TY 1) - Sign CMU	S.F.	380	\$25.00	\$9,500.00
1002 6002	LS Amenity (TY 1) - Sign Stone (includes cast stone)	S.F.	910	\$30.00	\$27,300.00
1002 6002	LS Amenity (TY 1) - Sign Column	Each	1	\$4,000.00	\$4,000.00
1002 6002	Planter Wall Footing	L.F.	46	\$30.00	\$1,380.00
0423 6004	Retaining Wall (Conc. Block)	S.F.	288	\$25.00	\$7,200.00
0424 6006	Retaining Wall (Stone) - includes cast stone cap	S.F.	288	\$30.00	\$8,640.00
0416 6001	Drilled Shaft 18" dia. Piers - for sign wall/tower/column	L.F.	60	\$130.00	\$7,800.00
0416 6052	Drilled Shaft 12" dia. Piers - for terraced planter walls	L.F.	40	\$100.00	\$4,000.00
0529 6013	Concrete Curb (Special) (Type II) - 12" Conc. Mowstrip	L.F.	1,380	\$12.00	\$16,560.00
1002 6003	LS Amenity (TY 2) - Total System: Lighting, Controller, & PV Panels	Each	3	\$4,000.00	\$12,000.00
0192 6027	Plant Material (100 gal. tree) - Live Oak	Each	11	\$900.00	\$9,900.00
0192 6030	Plant Material (3 gal. shrub) - Maiden Grass	Each	276	\$28.00	\$7,728.00
0192 6028	Plant Material (1 gal. shrub) - Weeping Love Grass & Mexican Feathergrass	Each	978	\$14.00	\$13,692.00
	Loose Aggregate for Groundcover - Colorado River Rock	S.F.	2,065	\$7.50	\$15,487.50
0192 6017	Vegetation Barrier - Filter fabric behind ret. walls & at Colorado River Rock beds	S.Y.	270	\$2.25	\$607.50
0192 6016	Plant Bed Preparation	S.Y.	600	\$15.00	\$9,000.00
0192 6013	Mulch	S.Y.	600	\$4.00	\$2,400.00
0164 6054	Bond FBR MTRX Seed (PERM) (RURAL) (SAND) - Hydromulch	S.Y.	4,222	\$1.00	\$4,222.00
	Tree Gator Bags - (1) per tree	Each	11	\$50.00	\$550.00
0168 6001	Vegetative Watering - First 90 days (water truck)	MG	45	\$12.00	\$540.00
0168 6006	Vegetative Watering - After first 90 days (water truck)	MG	45	\$12.00	\$540.00

<b>TOTAL</b>				<b>\$209,277.00</b>
<b>10% Contingency</b>				<b>\$20,927.70</b>
<b>Sub-Total I</b>				<b>\$230,204.70</b>

<b>Subtotal I</b>	\$230,204.70
<b>10% General Conditions</b>	\$23,020.47
<b>Subtotal II</b>	\$253,225.17
<b>Sub-Total II</b>	\$253,225.17
<b>10% Bonds &amp; Contractors Fee</b>	\$25,322.52
<b>Total</b>	\$278,547.69
<b>GRAND TOTAL</b>	<b>\$278,547.69</b>

The design professional has no control over the cost of labor, materials, or equipment, the contractor's method of determining prices, the competitive bidding process or market conditions. Opinions of probable cost provided here are made on the basis of experience and qualifications. These opinions represent the best judgment as a design professional familiar with the construction industry. However, the design professional cannot and does not guarantee that proposals, bids, or construction cost will not vary from the opinions of probable cost that have been prepared. If the owner wishes greater assurance as to the construction cost, an independent cost estimator should be employed.

**Note: OPINION OF COST DOES NOT INCLUDE:**

- 1. Professional fees.**



# City of Killeen

## Legislation Details

---

**File #:** RS-15-015B    **Version:** 1    **Name:** Landscape Maintenance Agreement for the Gateway Monument (at SH 195 city limits)

**Type:** Resolution    **Status:** Resolutions

**File created:** 4/21/2015    **In control:** City Council Workshop

**On agenda:** 5/19/2015    **Final action:**

**Title:** Consider a memorandum/resolution to authorize the City Manager to execute a landscape maintenance agreement for the Gateway Monument project with the Texas Department of Transportation.

**Sponsors:** Public Works Department, Transportation Division

**Indexes:**

**Code sections:**

**Attachments:** [Council Memorandum](#)  
[TxDOT Letter Agreement](#)  
[Attachment-A](#)

Date	Ver.	Action By	Action	Result
------	------	-----------	--------	--------

## CITY COUNCIL MEMORANDUM

### AGENDA ITEM

Consider a memorandum/resolution to authorize the City Manager to execute a landscape maintenance agreement for the Gateway Monument project with the Texas Department of Transportation

### ORIGINATING DEPARTMENT

Public Works - Transportation Division

### BACKGROUND INFORMATION

On April 25, 2014, the City of Killeen (City) and the Texas Department of Transportation (TxDOT) entered into a municipal maintenance agreement, wherein the City agreed to retain all functions and responsibilities for maintenance and operations which are not specifically described as the responsibility of TxDOT. On April 20, 2015, the City received a letter from TxDOT requesting the City enter into a landscape maintenance agreement associated with the proposed gateway and landscaping to be located near the Killeen city limits on SH 195.

### DISCUSSION/CONCLUSION

As part of the Gateway Monument project, the overpass includes aesthetic elements where watering and maintenance are required. These elements include, but are not limited to, trees, shrubs, grasses, sidewalks, irrigation systems, and hardscape features. Section 221.002 of the Transportation Code authorizes the State, at its discretion, to enter into agreements with cities to fix responsibilities for maintenance, control, supervision, and regulation of State highways within and through the corporate limits of such cities.

By entering into this landscape maintenance agreement, the City accepts responsibility for the maintenance of all landscape elements within the limits of the right of way including all median and island areas, but excluding paved areas intended for vehicular travel; landscape maintenance shall include, but not be limited to, plant maintenance, plant replacement, mowing and trimming, hardscape element maintenance, and irrigation system operation and maintenance.

The Gateway Monument landscape maintenance will be funded by the PTF 195/201 Construction Fund through the closing of the project. Upon completion, the landscape maintenance should convert to City standard procedures. The timeframe for the project completion is unknown at this time. The construction management, including bidding, will be performed by TxDOT.

### FISCAL IMPACT

There is no cost involved with this agreement at this time. Upon completion of the project, the landscape maintenance should convert to City standard procedures.

## **RECOMMENDATION**

Staff recommends that the City enter into the landscape maintenance agreement for the Gateway Monument project with the Texas Department of Transportation and that the City Manager is authorized to execute any and all change orders within the amounts set by state and local law.





## Texas Department of Transportation

100 SOUTH LOOP DRIVE • WACO, TEXAS 76704-2858 • (254) 867-2700

April 20, 2015

George Lueck  
City of Killeen  
200 East Ave. D  
Killeen, TX 76541

CSJ 0836-02-069  
Bell County – SH 195 Gateway  
Landscape Construction Project

Dear Mr. Lueck:

Enclosed you will find two copies of the Landscape Maintenance Agreement between the city of Killeen and the Texas Department of Transportation. This agreement covers the proposed gateway and landscape located near the Killeen city limits on SH 195 associated with the 2011 Governor's Community Achievement Award.

If you would please have the city manager sign both copies, return them to me, and I will have Mr. Littlefield sign them. One original will be for the city, and the other original will be for the State's records. We very much appreciate the willingness of the city of Killeen to provide long term maintenance for this project and thank you in your support of not only beautifying your city, but also beautifying the right-of-way of the state of Texas.

I just need to mention that in the event of future construction in the area, the State will coordinate with the City of Killeen in the removal and possible replacement/relocation of the landscape mentioned above. Please do not hesitate to contact me at (254)867-2726 should you have any further questions. I'm looking forward to seeing this "welcoming addition" to the city of Killeen!

Sincerely,

Betsy F. Pittman, RLA  
Waco District Landscape Architect  
Texas Department of Transportation

Enclosure

2 Landscape Maintenance Agreements with Attachments

## LANDSCAPE MAINTENANCE AGREEMENT

**ORIGINAL**

THE STATE OF TEXAS

THE COUNTY OF TRAVIS

This AGREEMENT made this \_\_\_\_\_ day of \_\_\_\_\_, 2015, by and between the Texas Department of Transportation, hereinafter referred to as the "State," and the City of Killeen, Bell County, Texas, acting by and through its duly authorized officers, hereinafter called the "City".

### WITNESSETH

**WHEREAS**, Chapter 311 of the Transportation Code gives the City exclusive dominion, control, and jurisdiction over and under the public streets within its corporate limits and authorizes the City to enter into agreements with the State to fix responsibilities for maintenance, control, supervision, and regulation of State highways within and through its corporate limits; and

**WHEREAS**, Section 221.002 of the Transportation Code authorizes the State, at its discretion, to enter into agreements with cities to fix responsibilities for maintenance, control, supervision, and regulation of State highways within and through the corporate limits of such cities; and

**WHEREAS**, the State and the City have entered into a Municipal Maintenance Agreement dated April 25, 2014, **the provisions of which are incorporated herein by reference**, and wherein the City has agreed to retain all functions and responsibilities for maintenance and operations which are not specifically described as the responsibility of the department; and

**WHEREAS**, the State has existing and proposed landscape improvements, such as, but not limited to, the installation of tree, shrub, and turf plantings, irrigation systems, and other aesthetic elements for areas within the right of way of state highway routes within the City as shown on Attachment "A"; and

**WHEREAS**, the State will provide such landscape improvements, provided that the City agrees to be responsible for all required maintenance of the landscape improvements.

## **AGREEMENT**

**NOW, THEREFORE**, in consideration of the premises and of the mutual covenants and agreements of the parties hereto to be by them respectively kept and performed, it is agreed as follows:

### **Contract Period**

This Agreement becomes effective upon the date of final execution by the State, and shall remain in effect until terminated or modified as hereinafter provided.

### **Coverage**

This agreement prescribes the responsibilities of the State and the City relating to the installation and maintenance of landscape elements on non-controlled access state highways, as defined in the Municipal Maintenance Agreement, and described and graphically shown as "State Maintained and Operated" in that agreement.

### **Amendment**

The parties agree that this agreement may be amended. Such amendments, to be effective, must be in writing and signed by both parties.

### **State's Responsibilities**

The State shall install landscape elements including but not limited to trees, shrubs, grasses, sidewalks, irrigation systems, and hardscape features through its employees or duly appointed agents.

### **City's Responsibilities**

The City may install landscape elements including but not limited to trees, shrubs, grasses, sidewalks, irrigation systems, and hardscape features through its employees or duly appointed agents. Any installations shall be performed in accordance with Texas Department of Transportation specifications and standards, and must be approved by the State in writing prior to any work being performed.



FILE LOCATION AND NAME

COUNTY BELL PROJ. NO. \_\_\_\_\_  
 HWY. NO. SH 195 LETTING DATE \_\_\_\_\_  
 DATE ACCEPTED \_\_\_\_\_

INDEX OF SHEETS

SHEET NO.	DESCRIPTION
1	TITLE SHEET
1A	INDEX OF SHEETS

# STATE OF TEXAS DEPARTMENT OF TRANSPORTATION

## PLANS OF PROPOSED STATE HIGHWAY IMPROVEMENT

FEDERAL AID PROJECT: NH 1502 (345)  
 BELL COUNTY  
 S.H. 195

NET LENGTH OF PROJECT = 270 FT = 0.051 MI.

LIMITS: AT KILLEEN SOUTH CITY LIMITS  
 FOR THE CONSTRUCTION OF LANDSCAPE & SCENIC ENHANCEMENT  
 CONSISTING OF LANDSCAPING AND GATEWAY

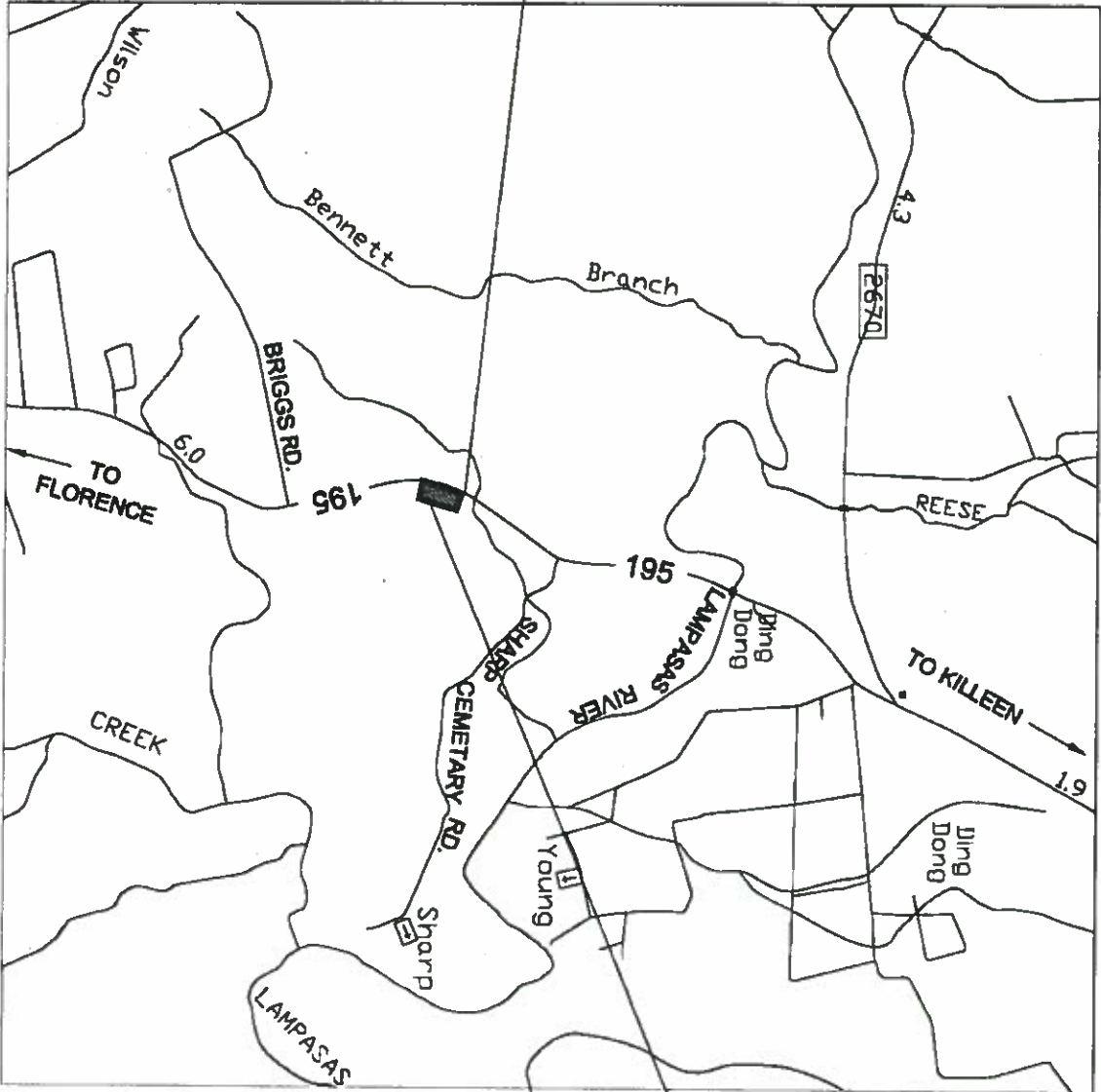

BEGAIN PROJECT  
 CSJ 0836-02-069  
 STA. 644+81  
 REF. 394+0.122

SPECIFICATIONS ADOPTED BY THE TEXAS DEPARTMENT OF TRANSPORTATION, NOVEMBER 1, 2014 AND SPECIFICATION ITEMS LISTED AND DATED AS FOLLOWS, SHALL GOVERN ON THIS PROJECT: REQUIRED CONTRACT PROVISIONS FOR ALL FEDERAL-AID CONSTRUCTION CONTRACTS (FORM FHWA 1273, MAY 2012).

EXCEPTIONS: N/A  
 EIGHTHED: N/A  
 RAILROAD CROSSINGS: N/A  
 SCALE: 1:4000

©2015 by Texas Department of Transportation; all rights reserved.

DATE	ISSUE NO.	REVISION
08/30/15	02	069

END PROJECT  
 CSJ: 0836-02-069  
 STA. 647+51  
 REF. MKR. 394+0.173

SUBMITTED FOR LETTING  
 3/24/2015  
 PROJECT MANAGER  
 WALKER PARTNERS, LLC  
 Scott Bell



RECOMMENDED FOR LETTING  
 4/13/2015  
 AREA ENGINEER  
 Carl B. Beck, P.E.

RECOMMENDED FOR LETTING  
 4-8-2015  
 DIRECTOR OF TRANSPORTATION PLANNING & DEVELOPMENT  
 Kevin G. Dierker, P.E.

APPROVED FOR LETTING  
 4-10-15  
 DISTRICT ENGINEER  
 D. D. [Signature]

ATTACHMENT 'A' (19 Pgs.)

**INDEX OF SHEETS**

SHEET NO.	DESCRIPTION
1	TITLE SHEET
1A	INDEX OF SHEETS
2, 2A-2D	GENERAL NOTES
3	ESTIMATE AND QUANTITY
4	SUMMARY OF QUANTITIES
5	SITE LAYOUT PLAN
6-7	HARDSCAPE PLANS
8-10	HARDSCAPE DETAILS
11-13	STRUCTURAL DETAILS
14	LANDSCAPE PLANS
15	LANDSCAPE DETAILS
16-17	PLANTING AND ESTABLISHMENT
18	SW3P
19	EPIC
20-31	*BC(1)-14 THRU BC(12)-14
32	*TCP(2-1)-12
33-42	*TA-BMP
43	*EC(1)-09

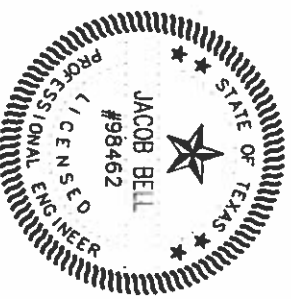

\*THE STANDARD SHEETS SPECIFICALLY IDENTIFIED ABOVE HAVE BEEN ISSUED BY ME AND ARE APPLICABLE TO THIS PROJECT.

*Jacob Bell*  
PE

4/8/2015



**KILLEEN GATEWAY  
MONUMENT AT S.H. 195**  
KILLEEN, TEXAS

**INDEX OF SHEETS**

NO.	REV.	DESCRIPTION	DATE	BY
1	A			
2	A			
3	A			
4	A			

**Texas Department of Transportation**  
© 2015

**DAVID C. BALDWIN**  
INCORPORATED



300 East Park Boulevard  
Suite 300 Temple, TX 76788  
TEL: 817/251-2288  
FAX: 817/251-2280  
WWW.DCBALDWIN.COM

CHARACTER	STATE	COUNTY	SHEET NO.
OWNER	TEXAS	WACO	BELL
SECTION	CONTROL	SECTION	JOB
PROJECT	0836	02	069
			1A



**SUMMARY OF QUANTITIES**

ITEM 0110 6001	EXCAVATION (ROADWAY)	ITEM 0160 6003	FURNISHING & PLACING TOPSOIL (4")	ITEM 0164 6054	BOND FIBR MTRX SEED (PERM) (RURAL) (SAND)	ITEM 0166 *	FERTILIZER	ITEM 0168 6001	VEGETATIVE WATERING	ITEM 0192 6013	MULCH	ITEM 0192 6016	PLANT BED PREPARATION	ITEM 0192 6017	VEGETATION BARRIER	ITEM 0192 6027	PLANT MATERIAL (100 GAL) (TREE)	ITEM 0192 6028	PLANT MATERIAL (1 GAL) (SHRUB)	ITEM 0192 6030	PLANT MATERIAL (3 GAL) (SHRUB)	ITEM 0193 6001	PLANT MAINTENANCE	ITEM 0193 6006	VEGETATIVE WATERING
CY	193	SY	950	SY	4222	TON	0.16	MG	280	SY	617	SY	600	SY	270	EA	11	EA	978	EA	276	MO	9	MG	105

ITEM 0416 6001	DRILL SHAFT (18 IN)	ITEM 0416 6052	DRILL SHAFT (12 IN)	ITEM 0423 6004	RETAINING WALL (CONC BLOCK)	ITEM 0423 6006	RETAINING WALL (STONE)	ITEM 0432 6047	RIPRAP (MOWSTRIP) (6 IN)	ITEM 0506 6038	TEMPSEDMT CONT FENCE (INSTALL)	ITEM 0506 6039	TEMPSEDMT CONT FENCE (REMOVE)	ITEM 1002 6002	LANDSCAPE AMENITY (TY 1)	ITEM 1002 6003	LANDSCAPE AMENITY (TY 2)	ITEM 1005 6001	LOOSE AGGREGATE FOR GROUNDCOVER (TYPE 1)
LF	60	LF	40	SF	288	SF	288	CY	26	LF	895	LF	895	EA	1	EA	3	CY	26

\* FOR CONTRACTOR'S INFORMATION ONLY.

FOR CONTRACTOR'S INFORMATION:

- ITEM 0160 6003 FURNISHING & PLACING TOPSOIL (4") INCLUDES:
  - SOIL AMENDMENT & FERTILIZER/COMPOST IS SUBSIDIARY TO THIS ITEM
- ITEM 0166 FERTILIZER INCLUDES:
  - FERTILIZER FOR ALL SEEDED AREA (0764 6054)
  - SUBSIDIARY TO ITEM 164
- ITEM 0168 6001 VEGETATIVE WATERING TO BE USED FOR THE FIRST 90 DAYS INCLUDES:
  - THE WATERING OF TREE GATOR BAGS IS SUBSIDIARY TO THIS ITEM
  - TURF GRASS WATERING IS BASED ON 13,100 GAL/AC PER APPLICATION (2 TIMES PER WEEK FOR 8 WEEKS)
  - TURF GRASS WATERING IS BASED ON 13,100 GAL/AC PER APPLICATION (1 TIME PER WEEK FOR THE FOLLOWING 4 WEEKS)
  - PLANT AND TREE WATERING IS BASED ON 1/2 X PLANT GALLON SIZE PER PLANT (3 TIMES PER WEEK)
- ITEM 0192 6027 (PLANT MATERIAL) (100 GAL TREE) (1 BAG PER TREE)
- ITEM 0193 6006 VEGETATIVE WATERING TO BE USED FOR 9 MONTHS AFTER THE FIRST 90 DAYS (0168 6001) INCLUDES:
  - THE WATERING OF TREE GATOR BAGS IS SUBSIDIARY TO THIS ITEM
  - NO TURF GRASS WATERING
  - PLANT AND TREE WATERING IS BASED ON 1/2 X PLANT GALLON SIZE PER PLANT (2 TIMES PER WEEK)
- ITEM 1002 6002 LANDSCAPE AMENITY (TY 1) INCLUDES:
  - MONUMENT TOWER
  - SIGN FOOTING
  - SIGN CMU
  - SIGN STONE
  - SIGN COLUMN
  - TERRACED PLANTER WALL FOOTING
- ITEM 1002 6003 LANDSCAPE AMENITY (TY 2) INCLUDES:
  - SOLAR LIGHTING SYSTEM



**KILLEEN GATEWAY MONUMENT AT S.H. 195**  
KILLEEN, TEXAS



1-25-15

**SUMMARY OF QUANTITIES**

**DAVID C. BALDWIN**  
INCORPORATED

LANDSCAPE ARCHITECTURE PLANNING

700 EAST TAKE BOWMAN  
SUITE 200 STAMPA, TX 76788

2015

Texas Department of Transportation

PROJECT NO. 0836

SECTION 02

DATE 069

NO. 4

COI	REV	DESCRIPTION	DATE	BY



CITY OF GEORGETOWN WATER LINE MAY BE PRESENT IN VICINITY OF CONSTRUCTION. LOCATE THIS UTILITY AND ALL UTILITIES PRIOR TO CONSTRUCTION. COORDINATE WITH ENGINEER TO RELOCATE PROPOSED FEATURES AS NECESSARY IN THE EVENT OF A UTILITY CONFLICT.

PROJECT SITE  
LANDSCAPE PLAN - SHEET 6  
LANDSCAPE PLAN - SHEET 14

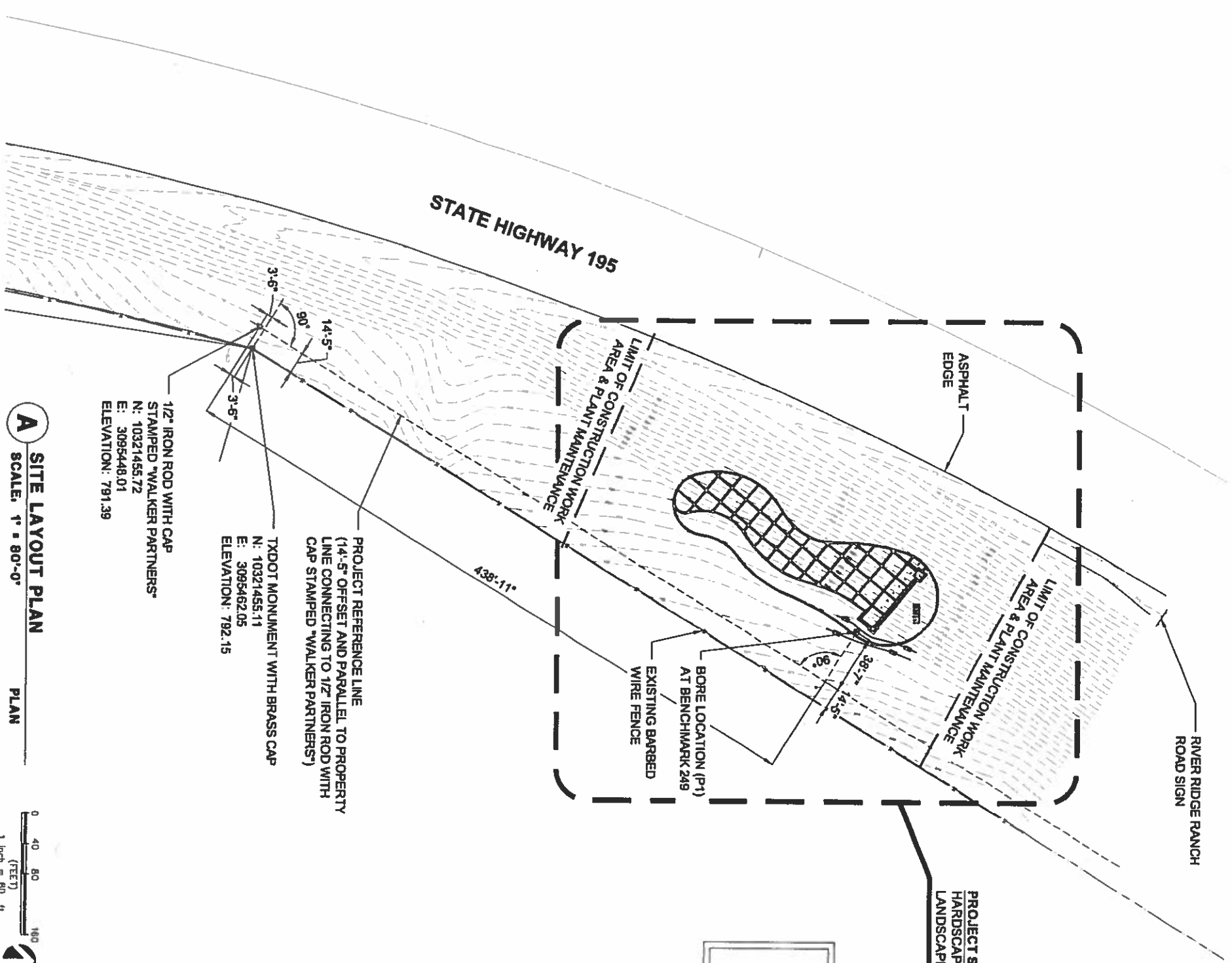

1/2" IRON ROD WITH CAP  
STAMPED "WALKER PARTNERS"  
N: 10321455.72  
E: 3095462.05  
ELEVATION: 791.39

PROJECT REFERENCE LINE  
(14'-5" OFFSET AND PARALLEL TO PROPERTY LINE CONNECTING TO 1/2" IRON ROD WITH CAP STAMPED "WALKER PARTNERS")  
TXDOT MONUMENT WITH BRASS CAP  
N: 10321455.11  
E: 3095462.05  
ELEVATION: 792.15

**A** SITE LAYOUT PLAN

SCALE: 1" = 80'-0"

PLAN





**KILLEEN GATEWAY MONUMENT AT S.H. 195**  
KILLEEN, TEXAS

**DAVID C. BALDWIN**  
INCORPORATED

LANDSCAPE ARCHITECTURE PLANNING & DESIGN

1001 EAST PEARL BOULEVARD  
SUITE 300 FLORENCE, TX 76734

TEL: 817.725.8088  
FAX: 817.725.8088  
WWW.DCBALDWIN.COM

**Texas Department of Transportation**  
2015

301 EAST PEARL BOULEVARD  
SUITE 300 FLORENCE, TX 76734

TEL: 817.725.8088  
FAX: 817.725.8088  
WWW.TDTPART.COM

NO.	REV.	DESCRIPTION	DATE	BY
1				
2				
3				

DESIGNER	STATE	DISTRICT	COUNTY	PROJECT NO.	DATE
DAVID C. BALDWIN	TEXAS	WACO	BELL	SH 195	08/31/15
DESIGNER	STATE	DISTRICT <td>COUNTY <td>PROJECT NO. <td>DATE </td></td></td>	COUNTY <td>PROJECT NO. <td>DATE </td></td>	PROJECT NO. <td>DATE </td>	DATE
DAVID C. BALDWIN	TEXAS	WACO	BELL	SH 195	08/31/15

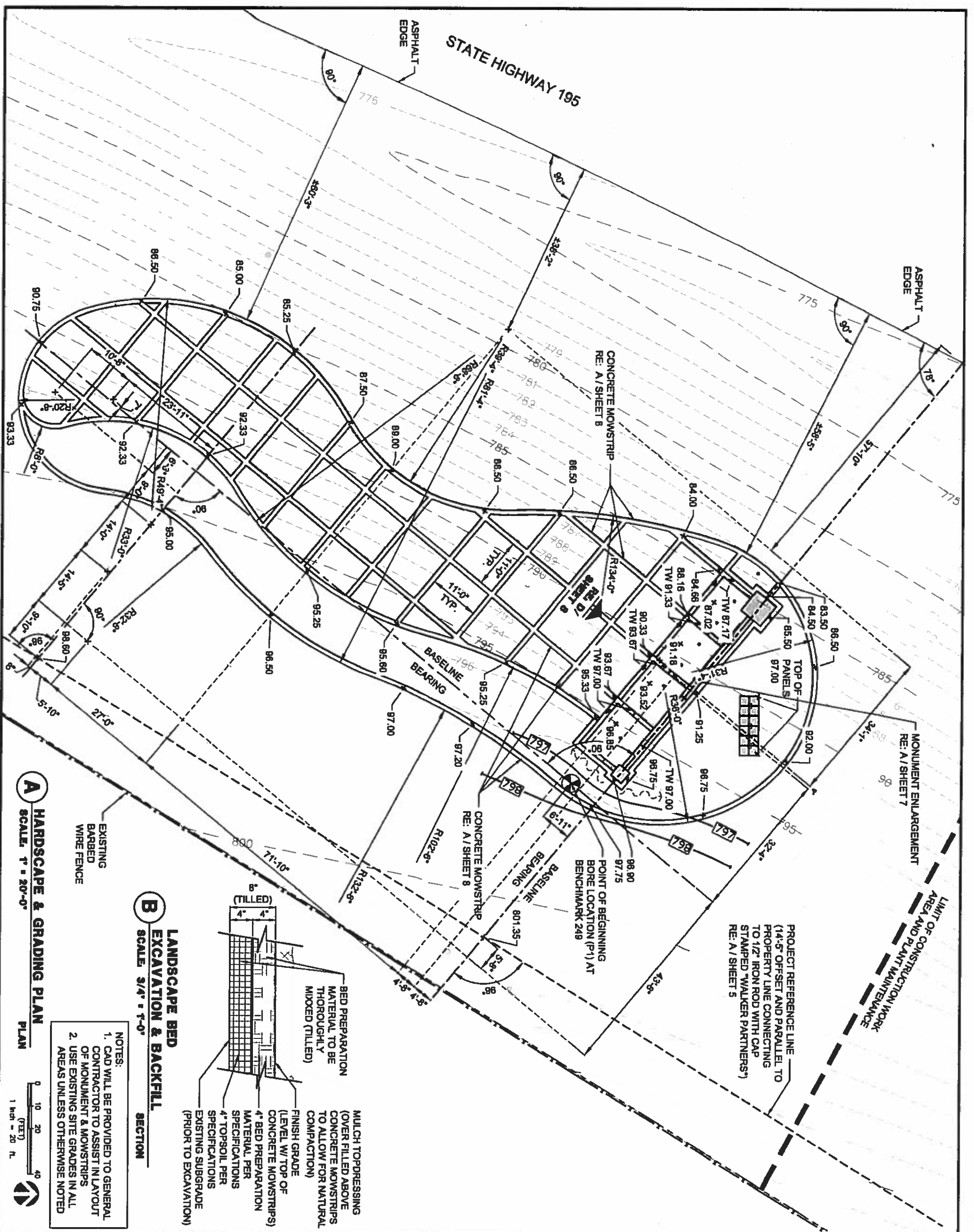

**A HARDSCAPE & GRADING PLAN**  
SCALE: 1" = 20'-0"

**B LANDSCAPE BED EXCAVATION & BACKFILL SECTION**  
SCALE: 3/4" = 1'-0"

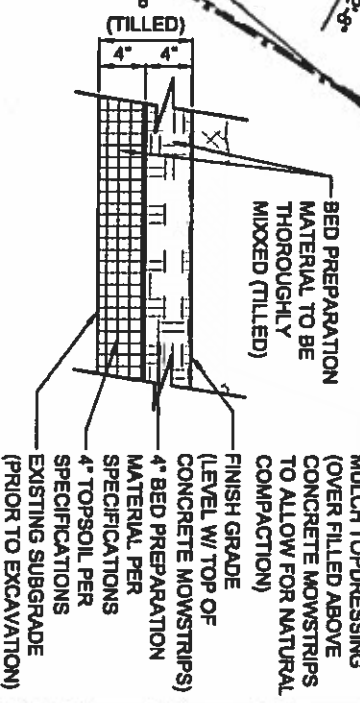

- NOTES:**
1. CAD WILL BE PROVIDED TO GENERAL CONTRACTOR TO ASSIST IN LAYOUT OF MONUMENT & MOWSTRIPS
  2. USE EXISTING SITE GRADES IN ALL AREAS UNLESS OTHERWISE NOTED

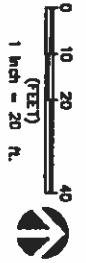

**KILLEEN GATEWAY MONUMENT AT S.H. 195**  
KILLEEN, TEXAS

**HARDSCAPE PLANS**

NO.	REV.	DESCRIPTION	DATE	BY
1	A			
2	B			

**DAVID C. BALDWIN**  
INCORPORATED  
LANDSCAPE ARCHITECTURE PLANNING

Texas Department of Transportation  
© 2015

NO.	DATE	SECTION	QUANTITY	BY
1	08/31/15	SH-195		
2	09/01/15	SH-195		
3	09/01/15	SH-195		
4	09/01/15	SH-195		
5	09/01/15	SH-195		
6	09/01/15	SH-195		

**TURN-KEY LIGHTING SCHEDULE**

KEY	QTY.	MODEL NO. & DESCRIPTION	MANUFACTURER
SOLAR LIGHTING SYSTEM	3	SYSTEM DESCRIPTION (EACH): BL-3FL-FD1B-03-20-P12 RUN TIME: DUSK-DAWN (2) 125W PANELS AT 30 DEGREES (3) 20W FLOODLIGHT LED LUMINAIRES (3) 100 AMP-HOUR BATTERIES FOR 5 DAY BACKUP (1) LOCKING BATTERY BOX WITH CONTROL PLATE (1) SUNLIGHT-20 CONTROLLERS SET DUSK TO DAWN (1) 12" ALUMINUM EMBEDDED POLE ENTIRE SYSTEM POWDER COATED IN BLACK	SOL. INC. CONTACT: CAROL HORTON PHONE: 772-873-7822 OR APPROVED EQUIVALENT

**LIGHTING NOTE:** PROPOSED LIGHTING AND ASSOCIATED ELECTRICAL SERVICE TO BE PROVIDED TURN-KEY BY INSTALLER. COORDINATE WITH MANUFACTURER AS REQUIRED.

**NOTE:**  
CONCRETE TO EXTEND 5 1/2" FROM EDGE OF FIXTURE ON ALL SIDES, SLOPE AWAY FROM FIXTURE ON ALL SIDES, AND PROVIDE 3/4" ROUNDED CORNERS ON ALL EDGES.

CONCRETE APPROX 3000 PSI  
(1) #3 E.W. REINFORCING STEEL TO PREVENT CONCRETE CRACKING DUE TO FIXTURE HEAT EXPANSION

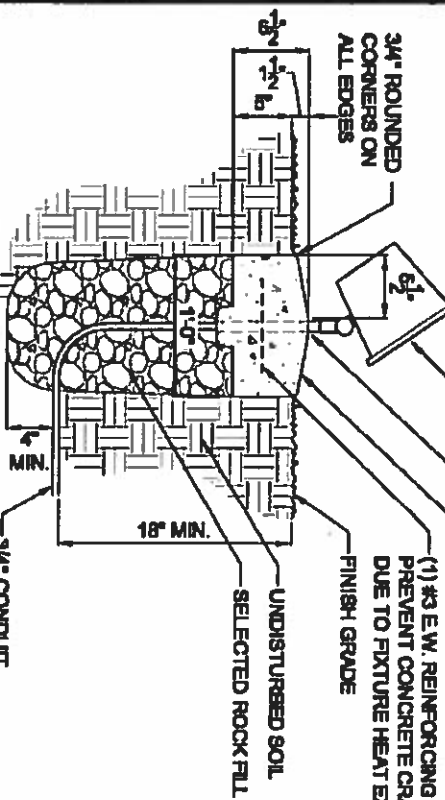

**B LIGHT FIXTURE (ISOLAR POWERED)**  
SCALE: 3/4" = 1'-0"

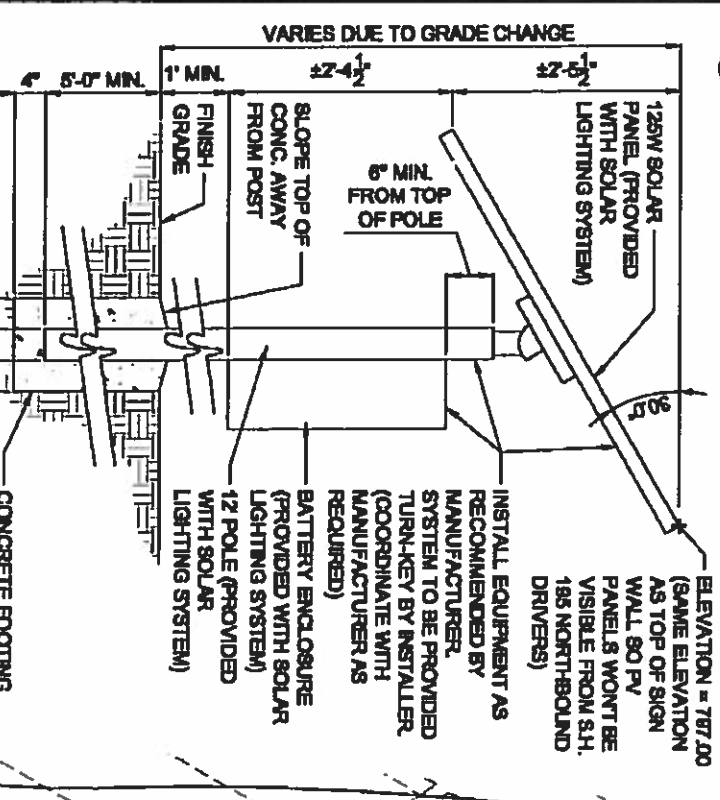

**C POLE FOOTING & ASSEMBLY SECTION**  
SCALE: 1/2" = 1'-0"

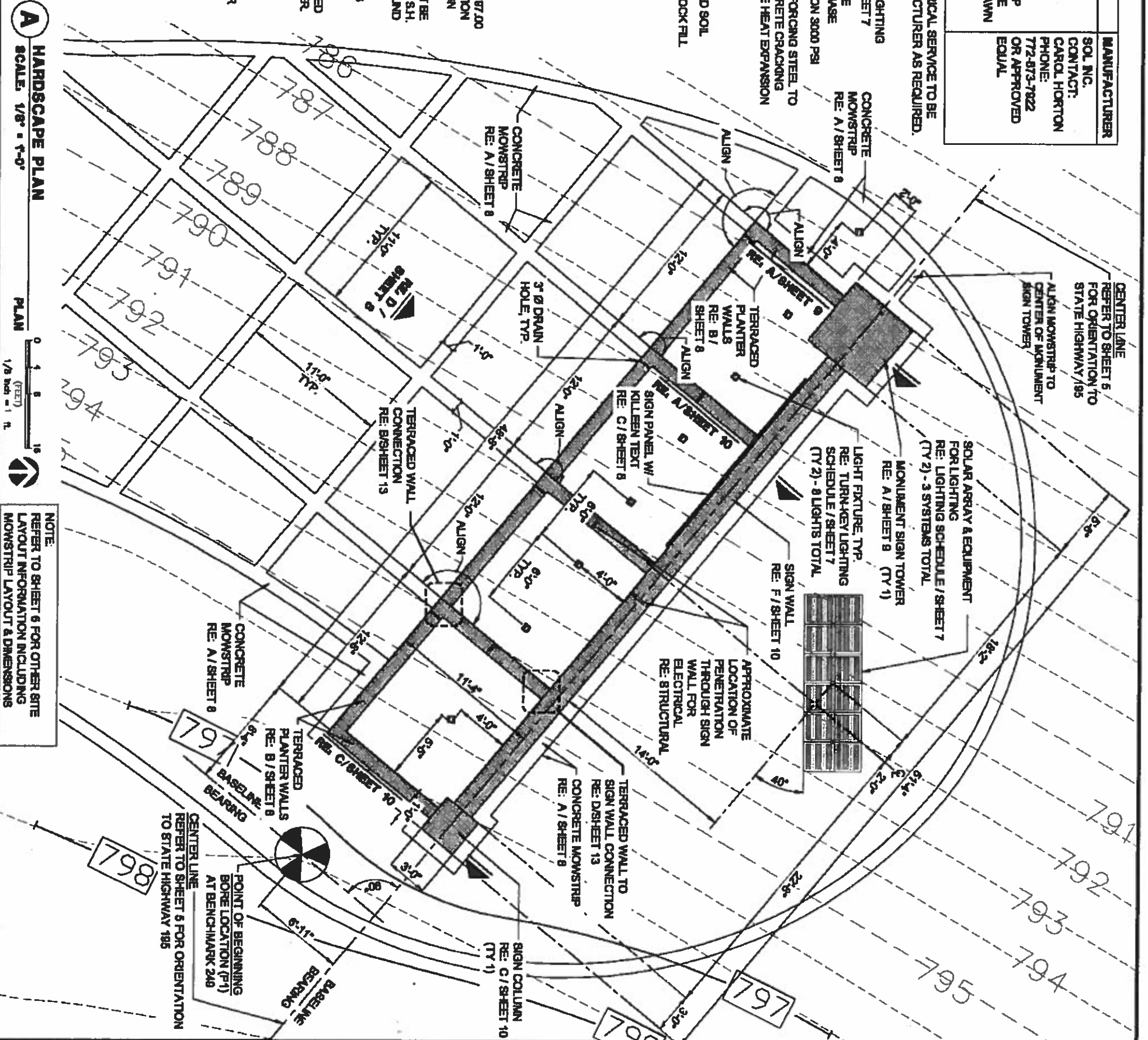

**A HARDSCAPE PLAN**  
SCALE: 1/8" = 1'-0"

NOTE:  
REFER TO SHEET 6 FOR OTHER SITE LAYOUT INFORMATION INCLUDING MOWSTRIP LAYOUT & DIMENSIONS

**KILLEEN GATEWAY MONUMENT AT S.H. 185**  
KILLEEN, TEXAS



3-25-15

**HARDSCAPE PLANS**

NO.	REV.	DESCRIPTION	DATE	BY
1	A			
2	A			

**DAVID C. BALDWIN INCORPORATED**  
LANDSCAPE ARCHITECTS P.L.L.C.

2815  
Texas Department of Transportation

DATE: 08/31/15  
SHEET: 7 OF 7

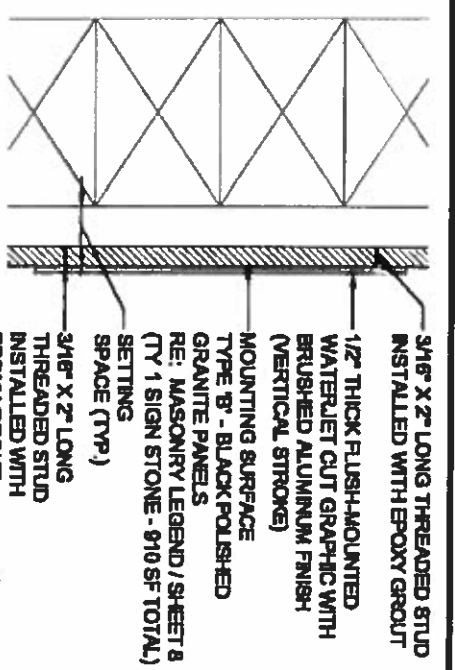

3/8" X 2" LONG THREADED STUD INSTALLED WITH EPOXY GROUT

1/2" THICK FLUSH-MOUNTED WATERJET CUT GRAPHIC WITH BRUSHED ALUMINUM FINISH (VERTICAL STROKES)

MOUNTING SURFACE

TYPE 'B' - BLACK POLISHED GRANITE PANELS  
RE: MASONRY LEGEND / SHEET 8 (TY 1 SIGN STONE - 910 SF TOTAL)

SETTING SPACE (TYP)

3/8" X 2" LONG THREADED STUD INSTALLED WITH EPOXY GROUT

MASONRY LEGEND			AVAILABLE LOCATION
ITEM	DESCRIPTION	AVAILABLE LOCATION	
CAST STONE (CAP & TRIM)	CAST STONE / SANDSTONE COLOR	AVAILABLE FROM ARLINGTON CAST STONE CONTACT: 817-284-6933 (OR APPROVED EQUAL.)	
TYPE 'A' BLACK POLISHED GRANITE (MONUMENT TOWER)	'MABABI BLACK', 2" MINIMUM THICKNESS, POLISHED, QUIRK JOINTS BETWEEN EDGES (4) PANELS TOTAL	COLD SPRINGS GRANITE COMPANY CONTACT: TERRY DUBE (612) 264-0191 (OR APPROVED EQUAL.)	
TYPE 'B' BLACK POLISHED GRANITE (BEHIND 'KILLEEN' TEXT)	'MABABI BLACK', 2" MINIMUM THICKNESS, POLISHED, QUIRK JOINTS BETWEEN EDGES (3) PANELS TOTAL	COLD SPRINGS GRANITE COMPANY	
HONED FINISH LIMESTONE	'RATTLESNACK' STONE SAWCUT WITH HONED (SMOOTH) FACE FINISH, 2" MINIMUM THICKNESS, QUIRK JOINTS BETWEEN STONE EDGES	ALLIANCE MATERIALS, INC. CONTACT: CHAD ROGERS (817) 578-0727 (OR APPROVED EQUAL.)	
RANDOM RECTANGULAR STONE	CHOPPED 'RATTLESNACK' STONE IN 6", 10" & 14" WIDTHS X RANDOM LENGTHS-RANDOM RECTANGULAR PATTERN	ALLIANCE MATERIALS, INC.	

**LOGO & TEXT NOTES:**

- THE LANDSCAPE ARCHITECT WILL PROVIDE A JPG FILE OF THE KILLEEN LOGO TO THE CONTRACTOR FOR THEIR USE.
- THE 'KILLEEN' TEXT WILL BE 2'-0" TALL AND THE FONT IS TO BE BASKERVILLE OLD FACE (REGULAR). IT WILL BE CENTERED IN THE PANELS AS SHOWN IN DETAIL D / SHEET 8.

MANUFACTURER: BENT INTO SHAPE, LLC  
CONTACT: CURT ROWLAND (888) 228-0688 (OR APPROVED EQUAL.)

**C GRAPHIC INSTALLATION KILLEEN LOGO AND TEXT I**  
SCALE: 1" = 7'-0" SECTION

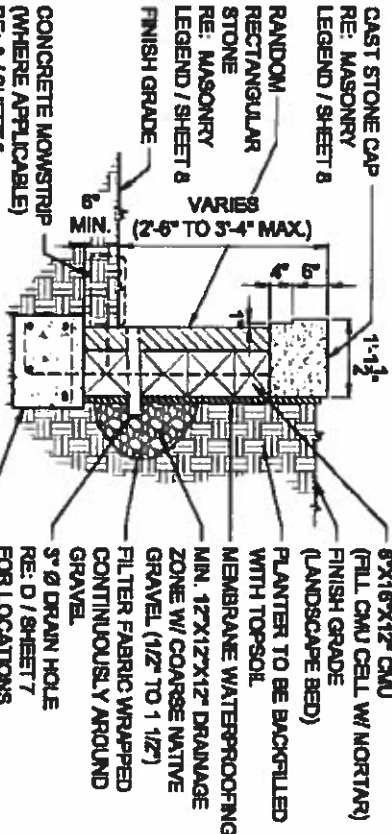

**B TERRACED PLANTER WALL**  
SCALE: 3/8" = 1'-0" SECTION

**A CONCRETE MOWSTRIP**  
SCALE: 1/2" = 1'-0" SECTION

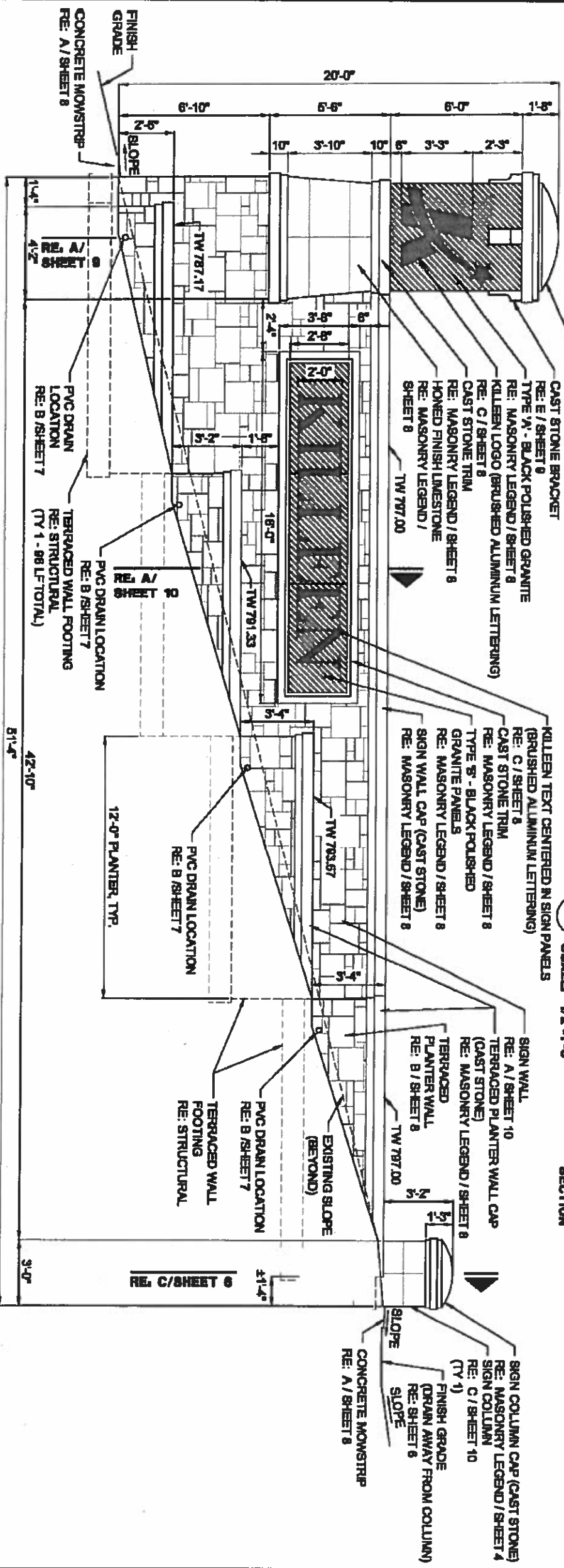
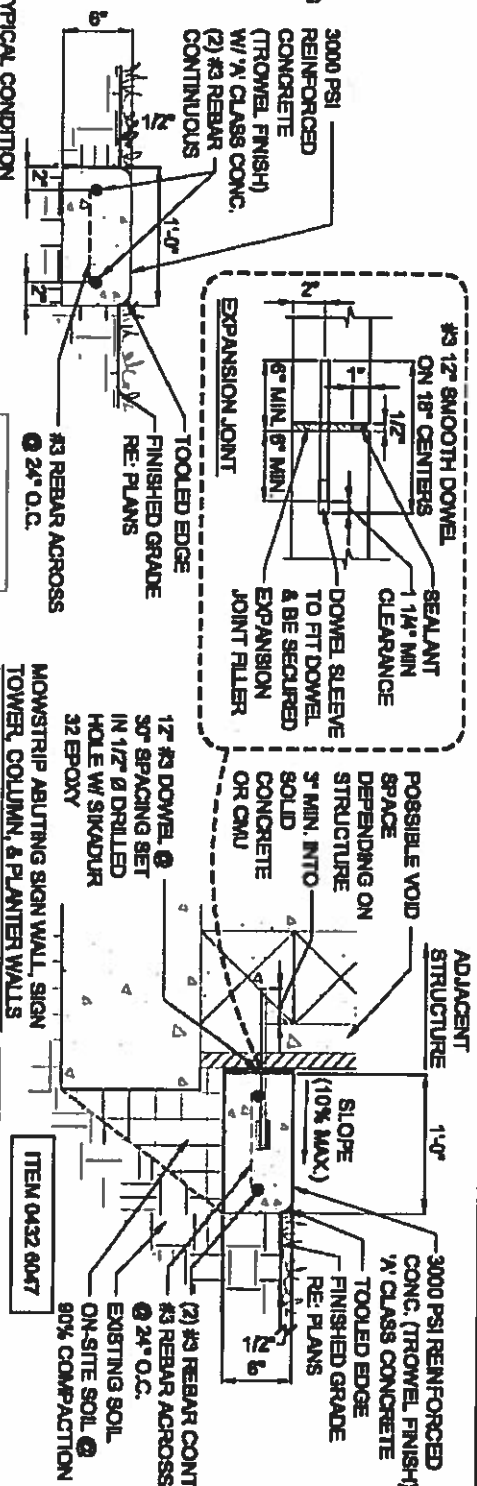

**D MONUMENT SIGN**  
SCALE: 3/16" = 1'-0" ELEVATION

NOTE: KILLEEN TEXT AND LOGO ARE ONLY LOCATED ON THE SOUTH SIDE OF MONUMENT SIGN (VISIBLE FROM THE S.H. 195 NORTHBOUND DIRECTION)



**HARDSCAPE DETAILS**

NO.	REV.	DESCRIPTION	DATE	BY
01	A			
02	A			

David C. Baldwin  
INCORPORATED  
2015



DATE	BY	DESCRIPTION
06/30/15	DAVID C. BALDWIN	FINAL DESIGN
06/30/15	DAVID C. BALDWIN	FINAL DESIGN



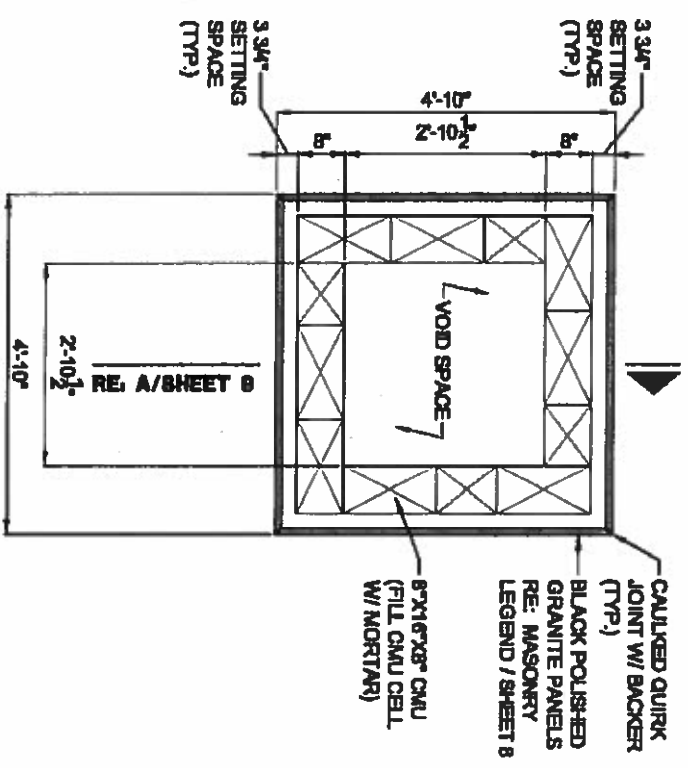

**C** MONUMENT SIGN TOWER SECTION  
SCALE: 3/8" = 1'-0"

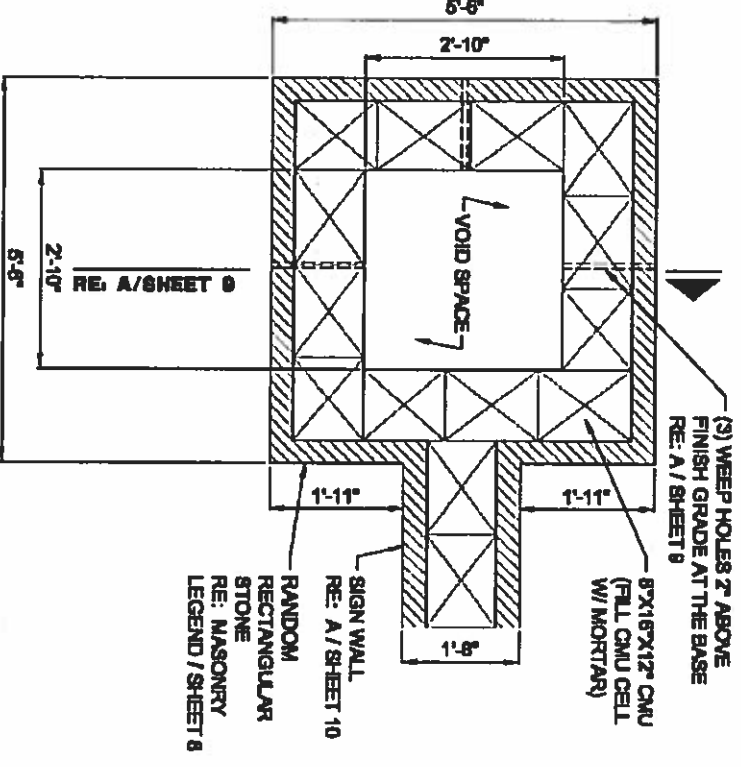

**B** MONUMENT SIGN TOWER SECTION  
SCALE: 3/16" = 1'-0"

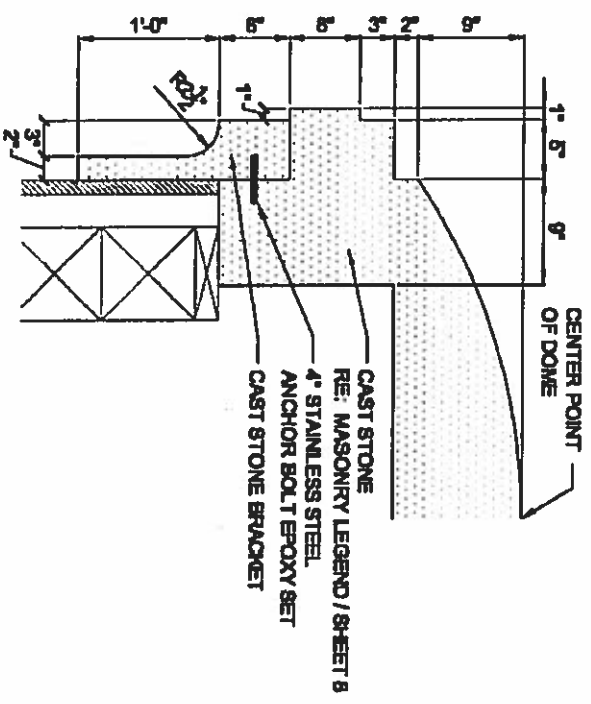

**E** MONUMENT SIGN TOWER CAP SECTION  
SCALE: 3/4" = 1'-0"

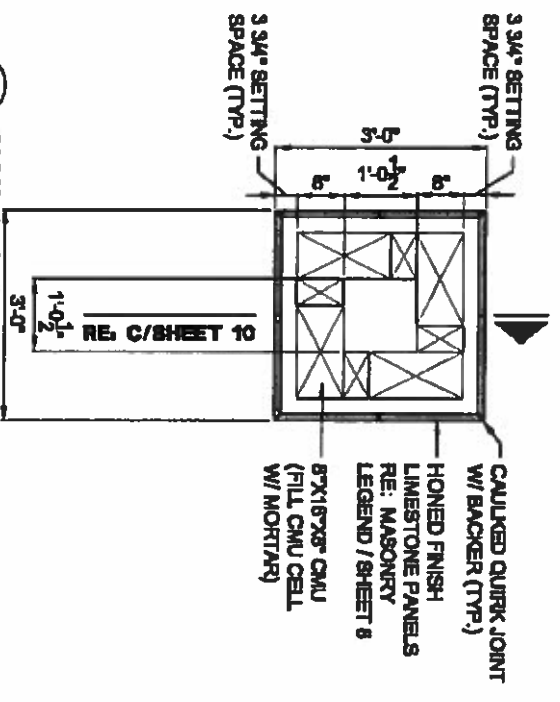

**D** SIGN COLUMN SECTION  
SCALE: 3/8" = 1'-0"

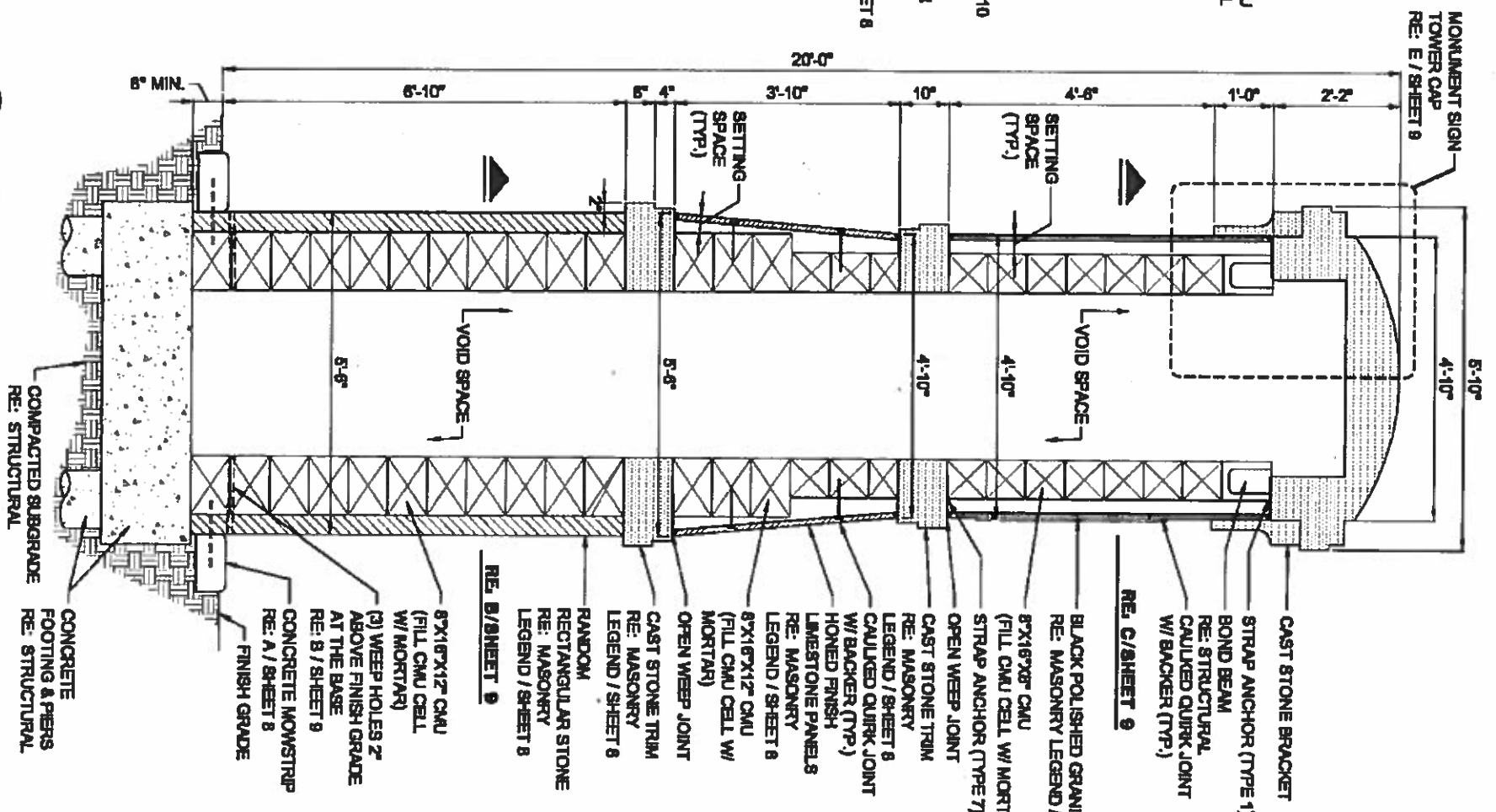

**A** MONUMENT SIGN TOWER SECTION  
SCALE: 3/8" = 1'-0"



**KILLEEN GATEWAY  
MONUMENT AT S.H. 195  
KILLBUCK, TEXAS**



**HARDSCAPE DETAILS**

NO.	REV.	DESCRIPTION	DATE	BY
01	A			
02	A			

**DAVID C. BALDWIN**  
INCORPORATED  
Texas Department of Transportation  
© 2015



PROJECT	LANDSCAPE ARCHITECTURE PLAN NO. 0	SHEET	SH 195
DATE	08/16	SCALE	AS SHOWN
DESIGNER	DAVID C. BALDWIN	CHECKER	DAVID C. BALDWIN
APPROVER	DAVID C. BALDWIN	DATE	08/16

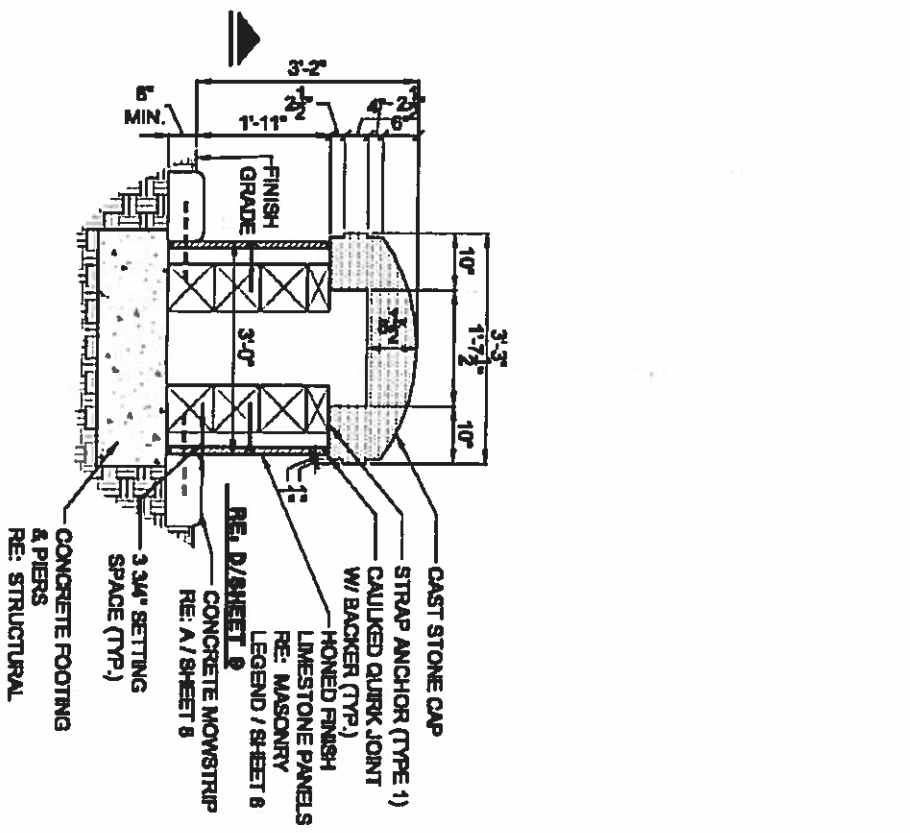

**C SIGN COLUMN**  
SCALE: 3/8" = 1'-0"  
SECTION

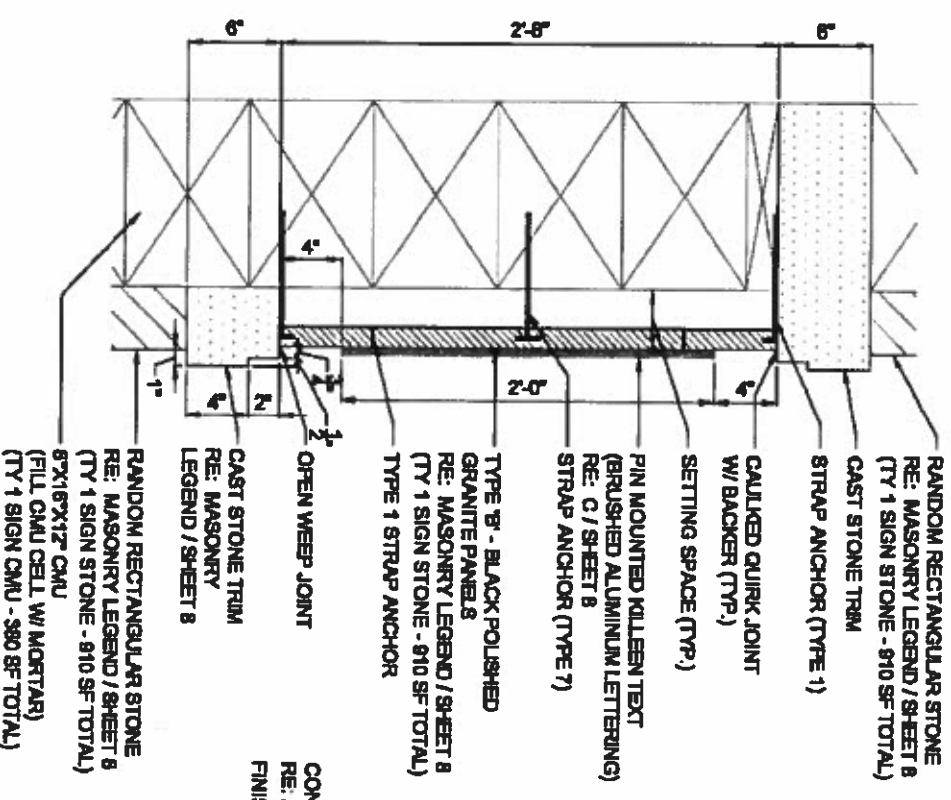

**B SIGN PANEL**  
SCALE: 1" = 1'-0"  
SECTION

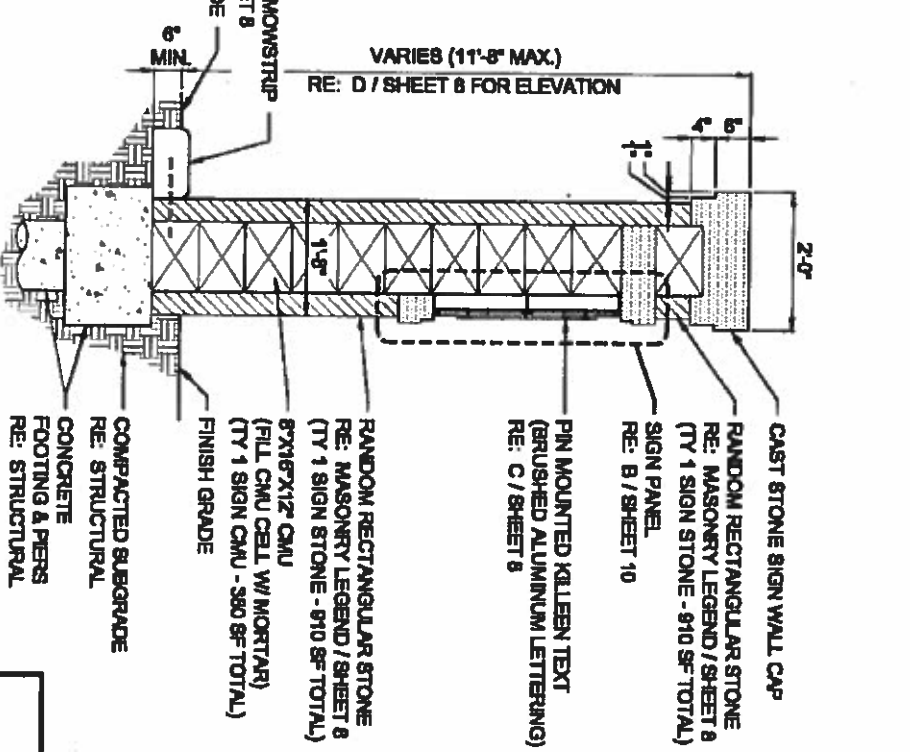

**A SIGN WALL**  
SCALE: 3/8" = 1'-0"  
SECTION



**KILLEEN GATEWAY MONUMENT AT S.H. 195**  
KILLEEN, TEXAS



3.25.15

**HARDSCAPE DETAILS**

NO.	REV.	DESCRIPTION	DATE	BY
1	A			
2	A			

**DAVID C. BALDWIN**  
INCORPORATED



200 East Park Boulevard  
Suite 100 Dallas, TX 75244  
© 2015

**Texas Department of Transportation**

CLIENT	PROJECT	DATE	BY
LAKSCAPE ARCHITECTURAL PLANNING	TEXAS WACO	02	069

Seismic Design Category - A, Risk Category I/II, Site Class C, Importance Factor 1.0  
 Design Wind Load - 30 psf 3sec gust - 115 mph, Exposure C

GENERAL NOTES:

1. Design complies with the 2012 International Building Code.
2. These details and specifications are applicable only for the site conditions & heights shown herein. If conditions change from those described herein, the engineer should be notified immediately to determine the effect, if any, on the design.
3. Pre-pour observation of footings and beams is recommended by or under the direction of a licensed professional engineer.
4. Positive drainage will be maintained at all times during & after construction and the ground around the structure should be watered during any dry periods. The intent is to maintain ground moisture as uniform as possible.

MATERIALS:

1. ALL MORTAR will be Type 'S' 1,800 psi @ 28 days. Grout shall be 2,500 psi w/ 6"-8" slump.
2. STONE & PATTERN will be approved by owner. Min. compressive strength will be 6,000 psi. Contractor shall provide quarry certification for stone materials provided.
3. CONCRETE will be as described in TxDOT Standard Specifications Item 421 and as follows:

LOCATION	CLASS
FOOTINGS/PIERS	'C'
MOWSTRIPS/FLATWORK	'A'

No. joint is allowed except as shown on these plans or approved in writing by the Engineer.

4. MASONRY construction will be in accordance with the latest edition of the Building Code Requirements for Masonry Structures (ASCE 5) & Specification for Masonry Structures (ASCE 6).
5. Reinforcing bars will be deformed Grade 60 bars conforming to ASTM A-615. Tie or stake all steel at 24" maximum spacing. Welding of reinforcing steel is not permitted unless specifically noted herein.
6. All reinforcing will top 40 bar diameters at splices for #7 bar and smaller, and 50 bar diameters for #8 and larger.
7. Detail concrete reinforcing and accessories accordance with the latest edition of ACI Publication 315 - "Details and Detailing of Concrete Reinforcement" and CRSI Manual of Standard Practice.

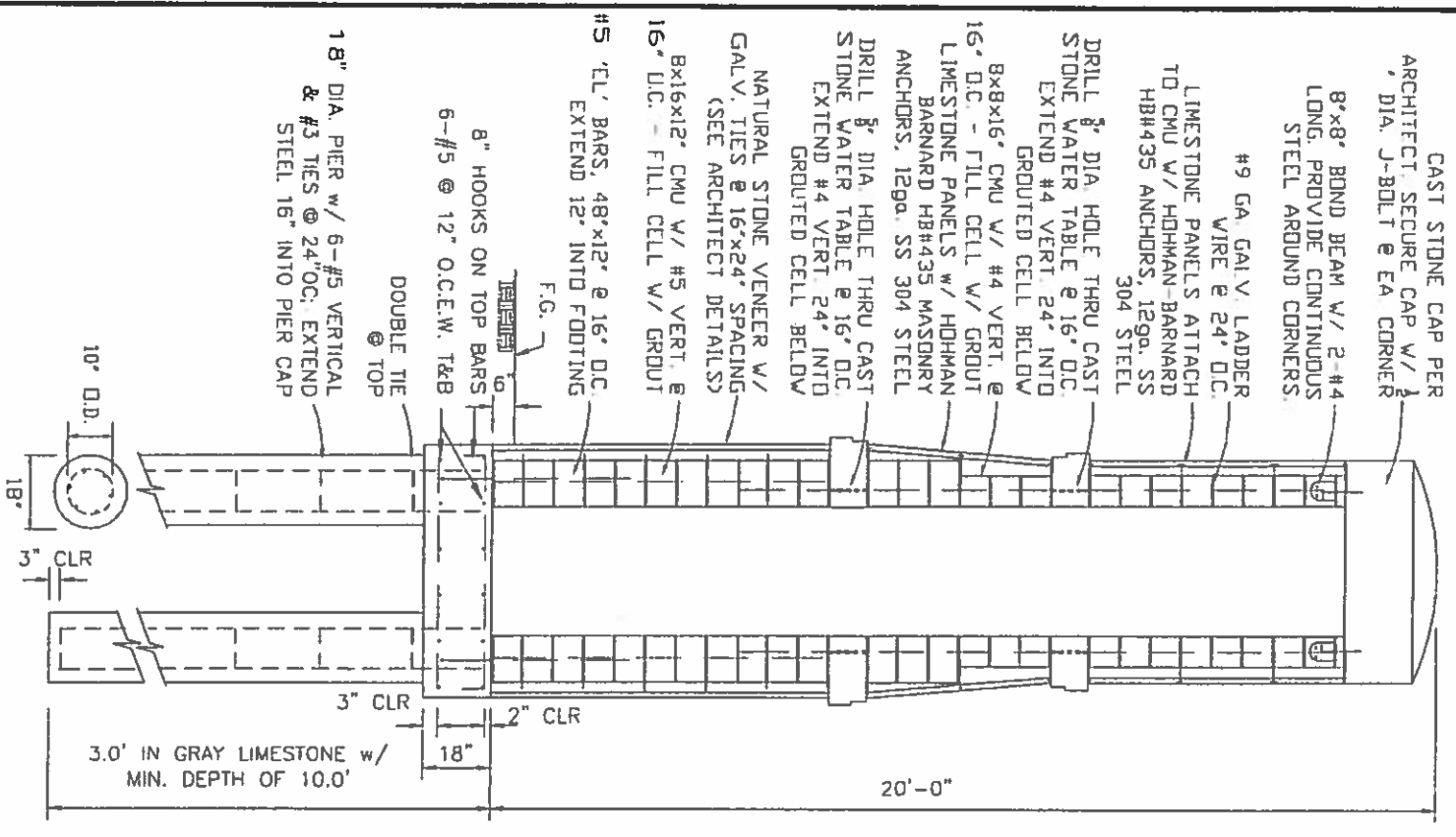

**A** TOWER SECTION  
1'-4"=1'

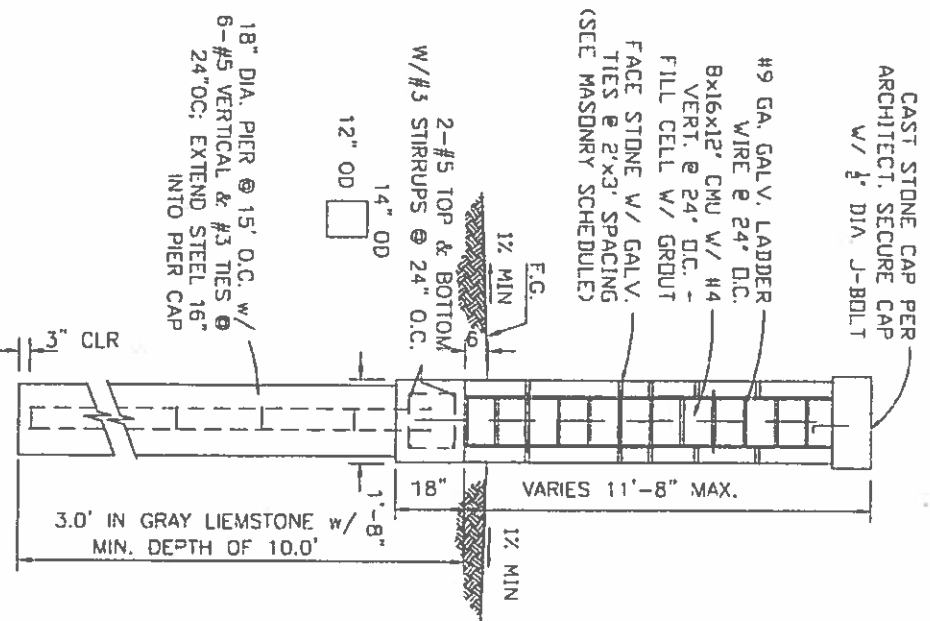

**C** SIGN WALL SECTION  
1'-4"=1'

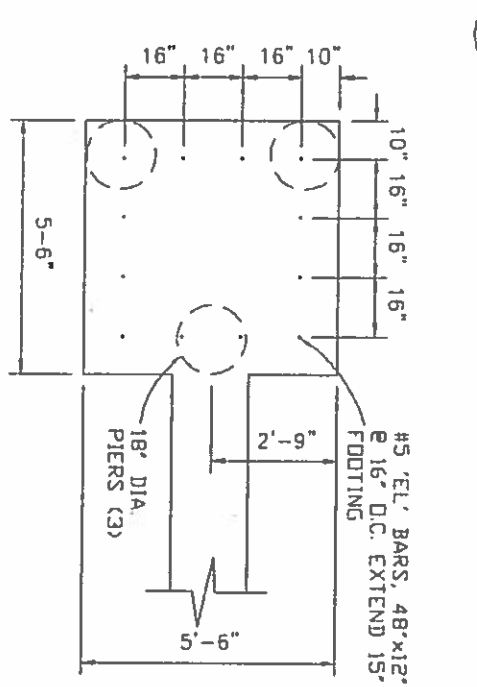

**B** TOWER FOUNDATION & DOWEL PLAN  
1'-4"=1'

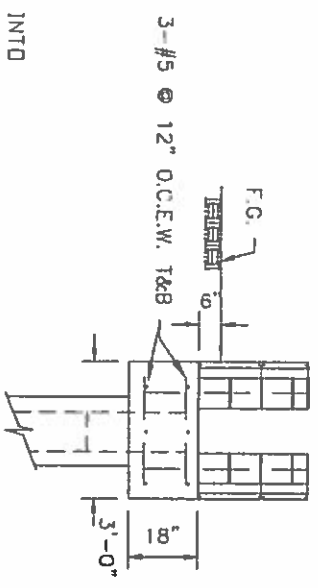

**E** COLUMN FOUNDATION SECTION  
1'-4"=1'

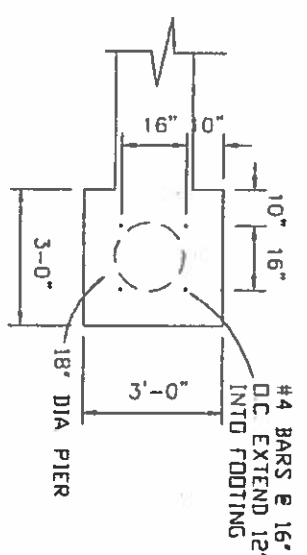

**D** COLUMN FOUNDATION & DOWEL PLAN  
1'-4"=1'

NOTE: DETAILS ARE FOR STRUCTURAL REFERENCE ONLY.  
 SEE ARCHITECT PLANS FOR APPEARANCE & DIMENSIONS

**KILLEN GATEWAY MONUMENT AT S.H. 195**  
KILLEN, TEXAS

**DAVID C. BALDWIN**  
INCORPORATED

120 East Park Building  
3000 East Road, Ft. Worth, TX 76104  
© 2015

Texas Department of Transportation

LANDSCAPE ARCHITECTURE & PLANNING

DESIGN	FIELD	FEDERAL AID PROJECT NO.	PROJECT NO.
DCBI	6		54 195
DATE	STATE	DISTRICT	SHEET
08/36	TEXAS	WACO	BELL
	DRAWN	SECTION	JOB
	02		069

NO.	REV.	DESCRIPTION	DATE	BY
1	A			

STRUCTURAL DETAILS

*David C. Baldwin* 3/25/15

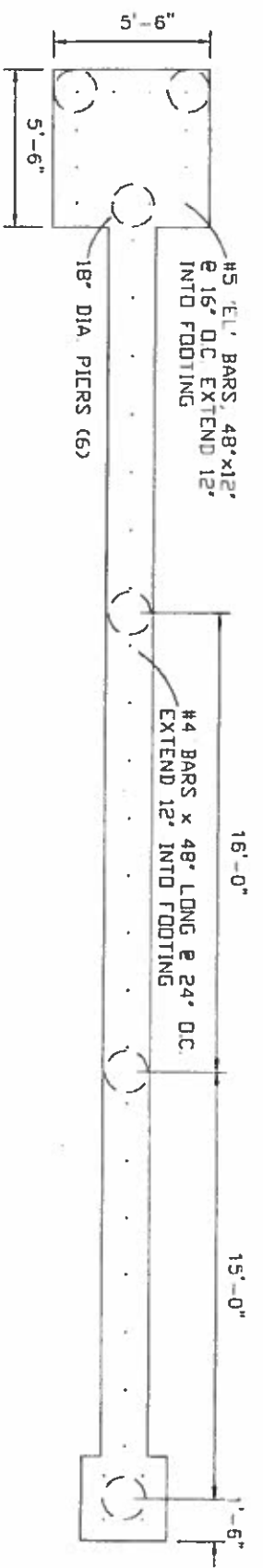

**A** SIGN FOUNDATION PLAN  
1-4/07

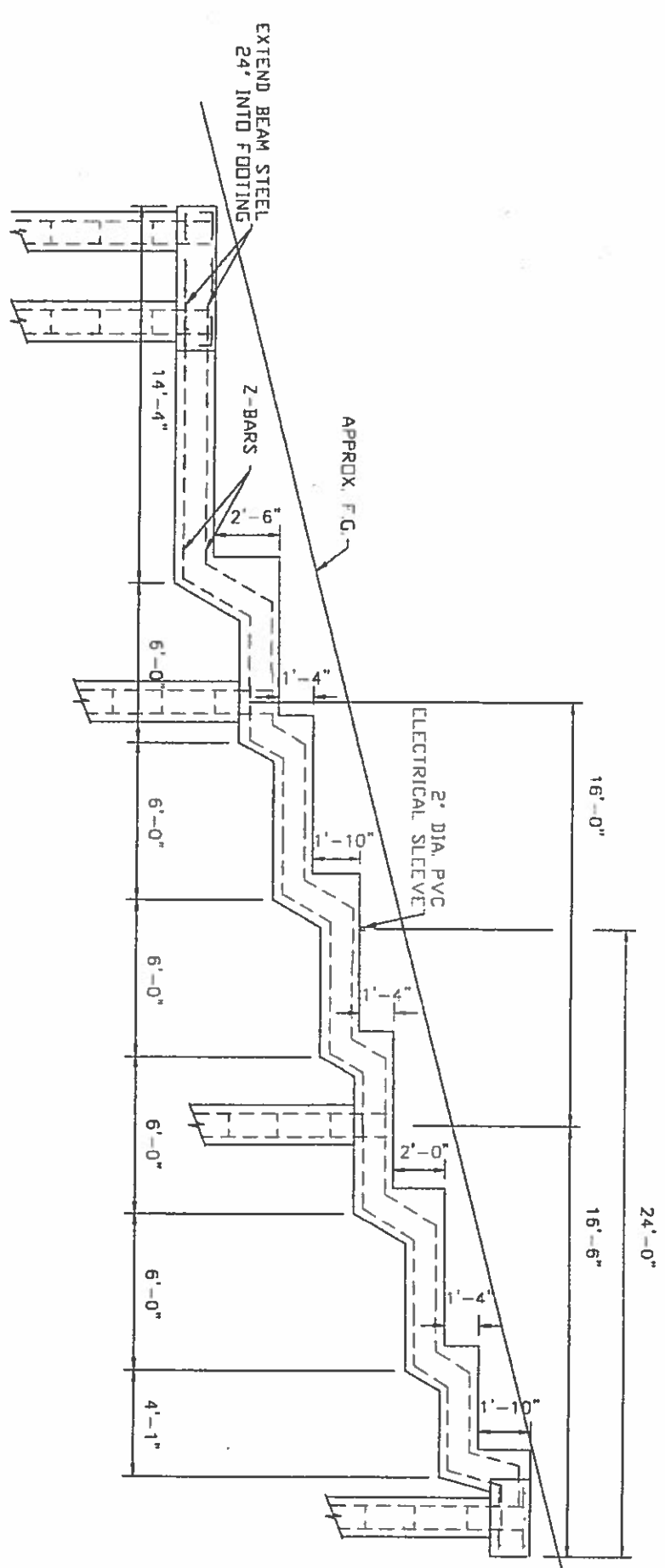

**B** SIGN FOUNDATION SECTION  
1-6/07

NOTE: DETAILS ARE FOR STRUCTURAL REFERENCE ONLY.  
SEE ARCHITECT PLANS FOR APPEARANCE & DIMENSIONS



**KILLEEN GATEWAY MONUMENT AT S.H. 195**  
KILLEEN, TEXAS

APPROVED FOR CONSTRUCTION  
  
 David C. Baldwin 3/25/15  
 STRUCTURAL DETAILS

CO. REV.	DESCRIPTION	DATE	BY
A			
A			

Texas Department of Transportation  
© 2015

**DAVID C. BALDWIN**  
INCORPORATED

REGION	DCB1	TIDISTRICT	5	FEDERAL PROJECT NO.	514 195	PROJECT NO.	08316	SECTION	02
STATE	TEXAS	COUNTY	WACO	BILL	08316	SECTION	02	069	12



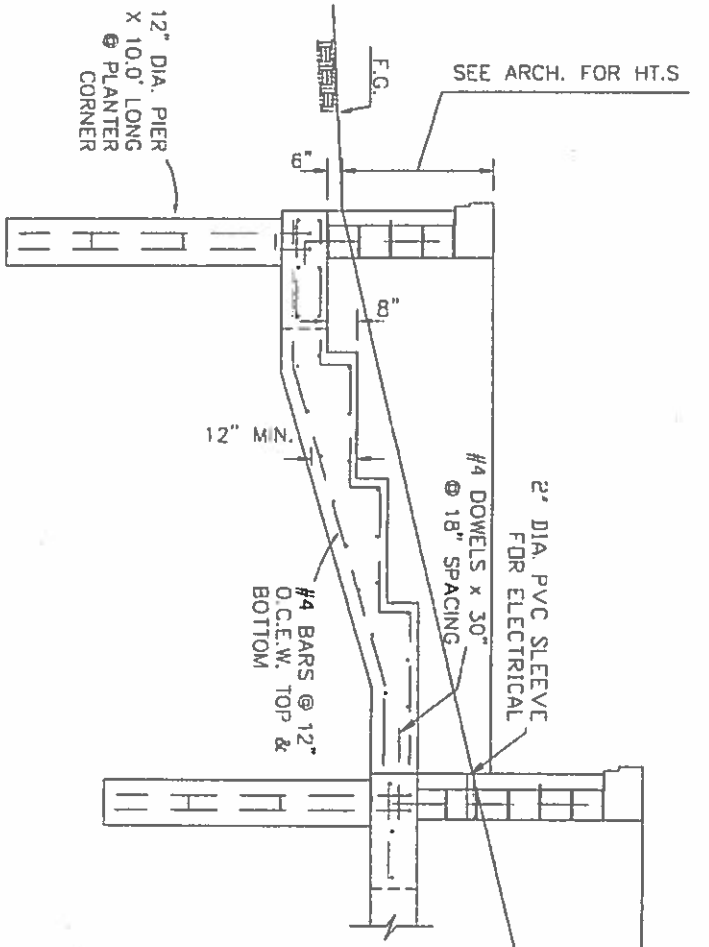

**B**  
PARTIAL PLANTER ELEVATION  
NTS

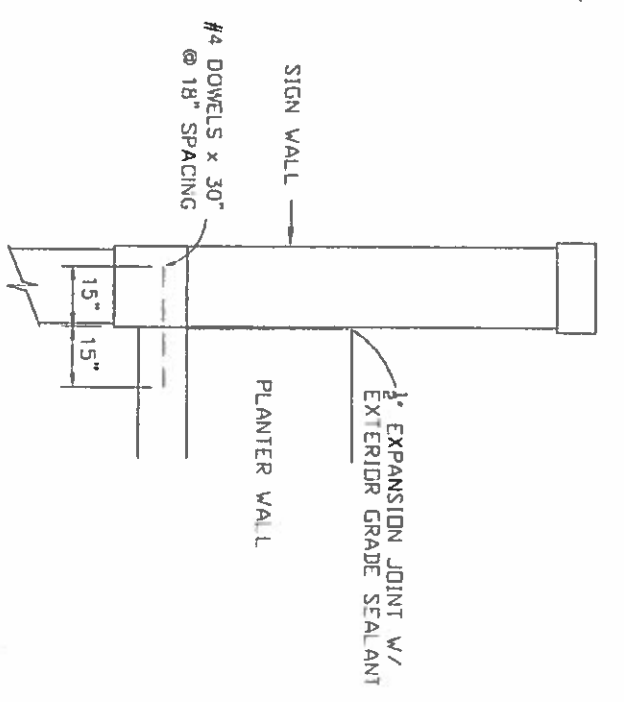

**D**  
PLANTER TO SIGN WALL CONNECTION  
NTS

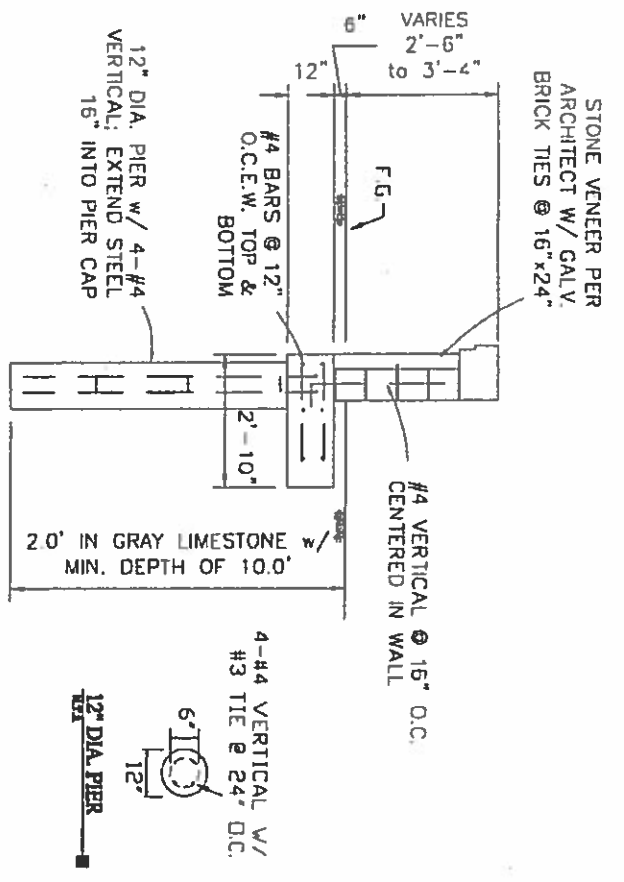

**A**  
PLANTER WALL SECTION  
NTS

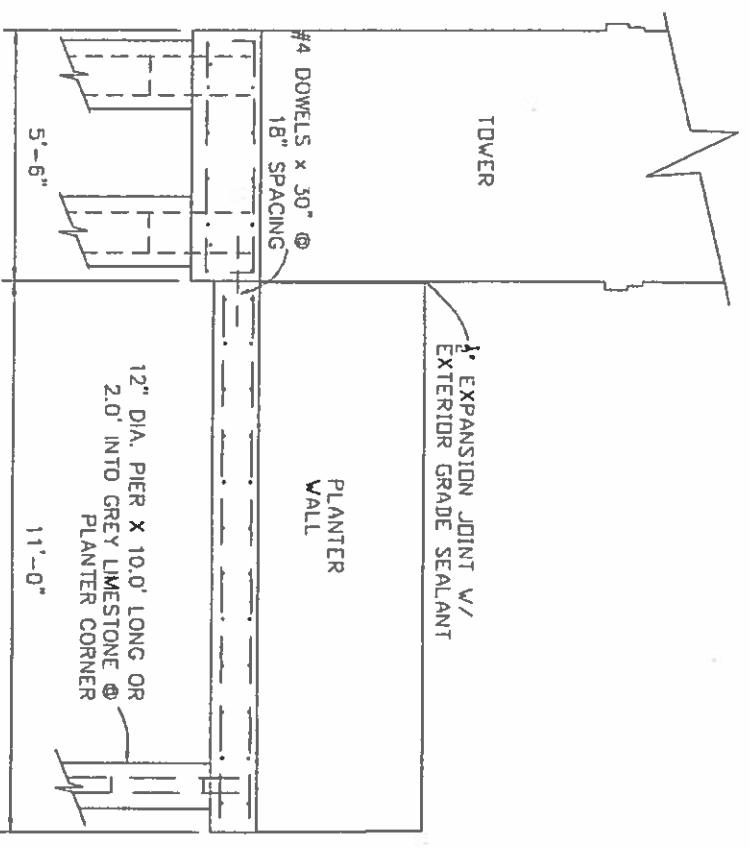

**C**  
TOWER / PLANTER SIDE ELEVATION  
NTS

NOTE: DETAILS ARE FOR STRUCTURAL REFERENCE ONLY. SEE ARCHITECT PLANS FOR APPEARANCE & DIMENSIONS.



**KILLEEN GATEWAY MONUMENT AT S.H. 195**  
KILLEEN, TEXAS

**DAVID C. BALDWIN**  
INCORPORATED

LANDSCAPE ARCHITECTURE & PLANNING

700 EAST PEARL STREET, SUITE 100, KILLEEN, TEXAS 76734  
TEL: 254.333.1888 FAX: 254.333.1889

© 2015  
Texas Department of Transportation

NO.	REV.	DESCRIPTION	DATE	BY
1	A			
2	B			
3	C			
4	D			
5	E			

DESIGNER: DCB

DRAWN BY: G

CHECKED BY: TEAS

DATE: 08/30/15

PROJECT NO: 009

DATE: 02

SCALE: 1/8" = 1'-0"

DESCRIPTION	QTY.	UNIT	SIZE/REMARKS
0190 6003 FURNISHING & PLACING TOPSOIL (4")	950	SY	ALL BEDS & COLORADO RIVER ROCK AREAS, A / SHEET 14
0194 6054 BOND FBR MTRX SEED (PERM) RURAL) (SAND)	4222	SY	HYDROMULCH
0192 6013 MULCH	617	SY	3" DEPTH, ALL BEDS & AROUND TREES
0192 6016 PLANT BED PREPARATION	600	SY	RE: B / SHEET 8
0192 6017 VEGETATION BARRIER	270	SY	RE: B / SHEET 8
0192 6027 PLANT MATERIAL (100 GAL TREE)	11	EA	LIVE OAK
0192 6028 PLANT MATERIAL (1 GAL) (SHRUB)	978	EA	WEEPING LOVE GRASS & MEXCAN FEATHER GRASS
0192 6030 PLANT MATERIAL (3 GAL) (SHRUB)	276	EA	MAIDEN GRASS
0193 6001 PLANT MAINTENANCE	9	MO	
1005 6001 LOOSE AGGREGATE FOR GROUND COVER (TYPE 1)	26	CY	COLORADO RIVER ROCK

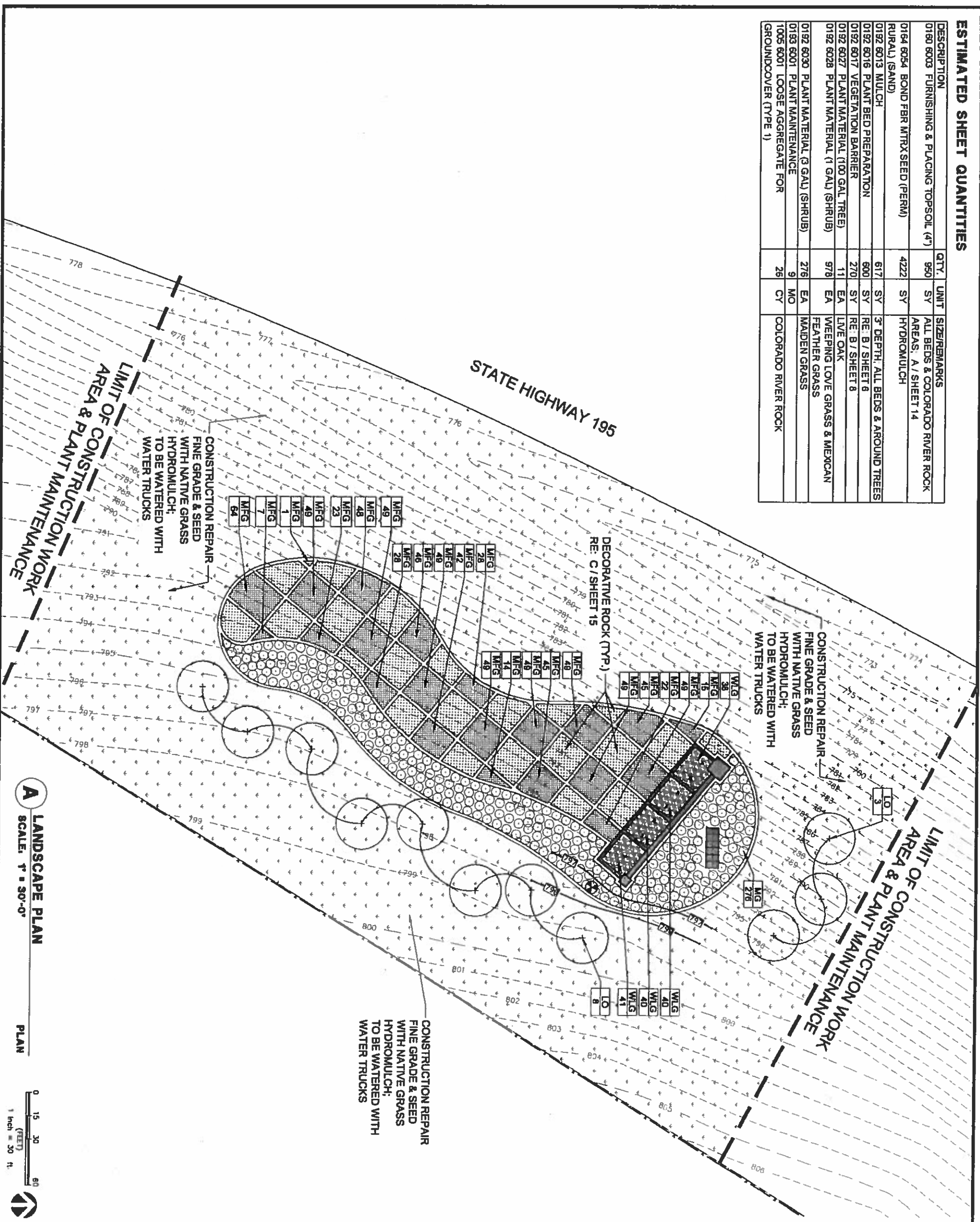

**A** LANDSCAPE PLAN  
SCALE: 1" = 30'-0"

PLAN

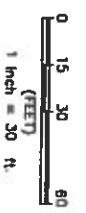



**KILLEEN GATEWAY MONUMENT AT S.H. 195**  
KILLEEN, TEXAS

LANDSCAPE PLANS

3.25.15

NO.	REV.	DESCRIPTION	DATE	BY
1	A			
2	A			

**DAVID C. BALDWIN**  
INCORPORATED

200 LAKE PARK BOULEVARD  
SUITE 200 FARMERS, TEXAS 76804

2815

**Texas Department of Transportation**

1029 10th Street  
Austin, Texas 78701

PROJECT NO. 069

DESIGNER	STATE	DISTRICT	COUNTY	PROJECT NO.	DATE
6	TEXAS	WACO	BELL	SH 195	14
CHECK					
0835				069	

**PLANT LIST**

KEY	QUANTITY (LANDSCAPE ARCHITECTS ESTIMATE ONLY)	COMMON NAME	BOTANICAL NAME	SIZE	REMARKS
LO	11	LIVE OAK	Quercus virginiana	100 gallon, minimum 4" caliper x 16' height x 6" spread	Container-grown, full head branching at ± 6' matched
M/G	276	MAIDEN GRASS	Miscanthus sinensis	3 gallon, minimum 12" height x 12" spread	Full; plant 42" o.c.
MFG	819	MEXICAN FEATHERGRASS	Stipa tenuissima	1 gallon, minimum 8" height x 8" spread	Full; plant 18" o.c.
WLG	159	WEeping LOVE GRASS	Eragrostis curvula	1 gallon, minimum 8" height x 8" spread	Full; plant 18" o.c.

**LANDSCAPE GENERAL NOTES:**

- QUANTITIES SHOWN ON PLANT LIST ARE LANDSCAPE ARCHITECTS ESTIMATE ONLY AND SHOULD BE VERIFIED PRIOR TO BIDDING. CONTRACTOR WILL BE RESPONSIBLE FOR BIDDING AND PROVIDING QUANTITY OF PLANTS REQUIRED AT SPACING DESIGNATED FOR BED SIZES AND CONFIGURATIONS SHOWN ON PLANS REGARDLESS OF QUANTITIES DESIGNATED ON PLANT LIST.
- CONTRACTOR WILL NOTIFY LANDSCAPE ARCHITECT OF ANY DISCREPANCIES, AMBIGUITY, OR UNLABELED PLANTS ON PLANS PRIOR TO BID SUBMITTAL. IF DISCREPANCY, AMBIGUITY, OR UNLABELED PLANT IS NOT CLARIFIED BY LANDSCAPE ARCHITECT PRIOR TO BID SUBMITTAL DATE, CONTRACTOR WILL NOTE SUCH ITEM ON BID.
- CONTRACTOR WILL PROVIDE REPRESENTATIVE SAMPLES OF SHRUB AND GROUND COVER STOCK FOR LANDSCAPE ARCHITECTS AND/OR OWNERS APPROVAL PRIOR TO MAJOR SHIPMENT OF MATERIALS TO SITE. IF REPRESENTATIVE SAMPLES CANNOT BE PROVIDED, CONTRACTOR WILL FURNISH GOOD QUALITY PHOTOGRAPH OF LANDSCAPE MATERIALS TO LANDSCAPE ARCHITECT AND/OR OWNERS. PHOTOGRAPHS WILL HAVE A MEANS OF DETERMINING SCALE AND SIZE OF MATERIALS WITHIN THE PHOTOGRAPH (I.E. FIELD POLE WITH ONE FOOT INCREMENT FOR TREES).
- AFTER TILLAGE AND CLEANING, ALL AREAS TO BE GRASSED WILL BE LEVELED, AND FINE GRADED. THE REQUIRED RESULT WILL BE THE ELIMINATION OF RUTS, DEPRESSIONS, HUMPS, AND OBJECTIONABLE SOIL CLODS. DURING THE SOIL PREPARATION PROCESS, A "ROCK PICK" OR "ROCK RAKE" WILL BE USED TO GATHER SURFACE STONES AS SMALL AS ONE INCH (1") IN DIAMETER.
- CONTRACTOR WILL GUARANTEE A FULL STAND OF GRASS, REGARDLESS OF WHETHER A PERMANENT LANDSCAPE IRRIGATION SYSTEM IS INSTALLED. CONTRACTOR WILL PROVIDE TEMPORARY IRRIGATION OR HAND WATER AS REQUIRED FOR TURF ESTABLISHMENT.
- SOIL AMENDMENT: "A PROFESSIONAL BEDDING SOIL" AS PRODUCED BY LIVING EARTH TECHNOLOGIES, INC., 1808 W. NORTHWEST HIGHWAY, DALLAS, TEXAS (PHONE: 214-869-4332) OR "NATURAL T. L. COMPOST" AS PRODUCED BY SOIL BUILDING SYSTEMS, INC., 1770 "Y" STREET, DALLAS, TEXAS (PHONE: 972-831-8187), OR APPROVED EQUAL. (SOIL AMENDMENT & FERTILIZER/COMPOST IS SUBSIDIARY TO ITEM 0160 6003 FURNISHING & PLACING TOPSOIL (4"))
- TREE HOLES TO BE EXCAVATED 2' GREATER THAN BALL DIAMETER AND 6" DEEPER.
- TREE BACKFILL SHOULD BE COMPOSED OF 5 PARTS OF EXISTING SOIL EXCAVATED FROM THE HOLE TO ONE PART SOIL AMENDMENT, THOROUGHLY MIXED WITH 5 LBS. PER CUBIC YARD BACKFILL FERTILIZER (13.13.13 ANALYSIS BULK FERTILIZER). TREE BACKFILL TO BE MECHANICALLY MIXED PRIOR TO BACKFILL OPERATIONS. (PAID AS ITEM 0192 8027 PLANT MATERIAL (100 GAL) (TREE))
- SHRUB PITS WILL BE EXCAVATED 12" GREATER THAN CONTAINER DIAMETER AND 6" DEEPER. BACKFILL WITH 1/2 EXISTING SOIL AND 1/2 SOIL AMENDMENT (OR APPROVED EQUAL) AS NOTED UNDER NOTE 7. ABOVE. THOROUGHLY BLENDED BY MECHANICAL MEANS PRIOR TO BACKFILL.
- SOIL PREPARATION FOR GROUND COVER, SHRUB, AND SEASONAL COLOR BEDS (PAID AS ITEM 0192-8018 PLANT BED PREPARATION):  
 A) EXCAVATE EXISTING SOIL, IF NECESSARY, AND ADD TO SHRUB, GROUND COVER, AND SEASONAL COLOR AREAS THE FOLLOWING:  
 - 4" LAYER OF COMPOST MIX (SOIL AMENDMENT & FERTILIZER/COMPOST IS SUBSIDIARY TO ITEM 0160 6003 FURNISHING & PLACING TOPSOIL (4"))  
 - 14-14-14 SLOW RELEASE FERTILIZER (OSMACOTE) AT A RATE OF 5 LBS. / 100 S.F. (SOIL AMENDMENT & FERTILIZER/COMPOST IS SUBSIDIARY TO ITEM 0160 6003 FURNISHING & PLACING TOPSOIL (4"))  
 B) SPREAD MATERIALS UNIFORMLY AND CULTIVATE THOROUGHLY BY MEANS OF A MECHANICAL TILLER. TILL TO A MINIMUM DEPTH OF 8".  
 C) POCKET PLANTING OF SHRUB, GROUND COVER, AND SEASONAL COLOR IS NOT ALLOWED.
- MULCH TOPDRESSING TO BE MINIMUM 3" LAYER DOUBLE SHREDDED HARDWOOD. SPREAD UNIFORMLY ON ALL SHRUB AND GROUND COVER BEDS AND ON ALL TREE SAUCERS. AVAILABLE FROM LIVING EARTH TECHNOLOGY (PHONE: 214-869-4332) OR APPROVED EQUAL.
- ALL HOLES FOR TREES AND LARGE SHRUBS WILL BE TESTED FOR WATER RETENTION PRIOR TO TREE OR SHRUB INSTALLATION. AFTER HOLE IS EXCAVATED, IT IS TO BE FILLED WITH WATER TO THE TOP OF THE EXCAVATION. IF, AFTER 24 HOURS, THE HOLE STILL HOLDS WATER, THE CONTRACTOR WILL EXCAVATE AN ADDITIONAL 6" FROM THE BOTTOM OF THE HOLE. THE LANDSCAPE CONTRACTOR WILL THEN INSTALL 6" OF NATIVE WASHED GRAVEL COVERED ON THE TOP (AND UP TO A MINIMUM OF 12" ON THE SIDES OF THE HOLE) WITH FILTER FABRIC. THE CONTRACTOR WILL ALSO INSTALL A CAPPED 3" DIAMETER PVC SUMP WHICH WILL EXTEND FROM NEAR THE BOTTOM OF THE ROCK LAYER TO 3" ABOVE THE PROPOSED FINISH GRADE SO THE HOLE CAN BE EVACUATED THROUGH MECHANICAL MEANS.

NOTE: THIS DETAIL APPLIES TO ALL LARGE ORNAMENTAL TREES 3" CALIBER AND GREATER.

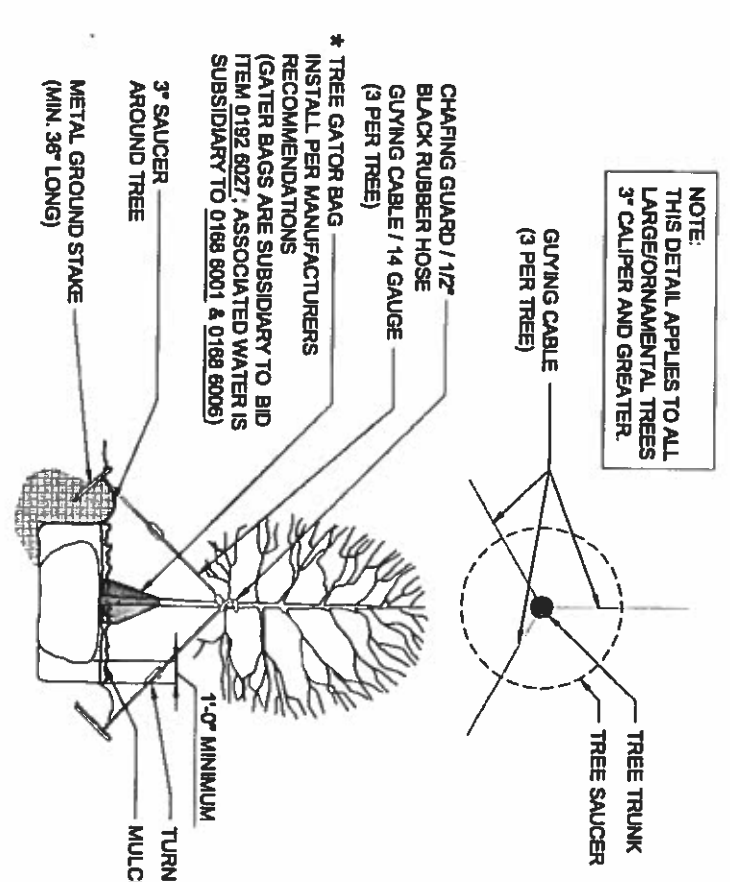

**A TREE GUYING DETAIL SECTION/ELEVATION**  
SCALE: N.T.S.

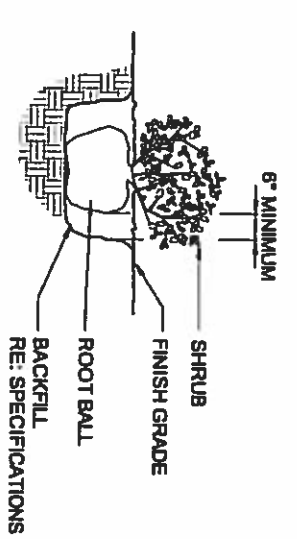

**B SHRUB PLANTING DETAIL SECTION/ELEVATION**  
SCALE: N.T.S.

RIVER ROCK TO BE "COLORADO RIVER ROCK"  
COLOR: SALT & PEPPER  
SIZE: 2" TO 3" DIA.  
SOURCE: CUSTOM STONE  
PHONE: 1 (844) 576-1364  
(OR APPROVED EQUAL)

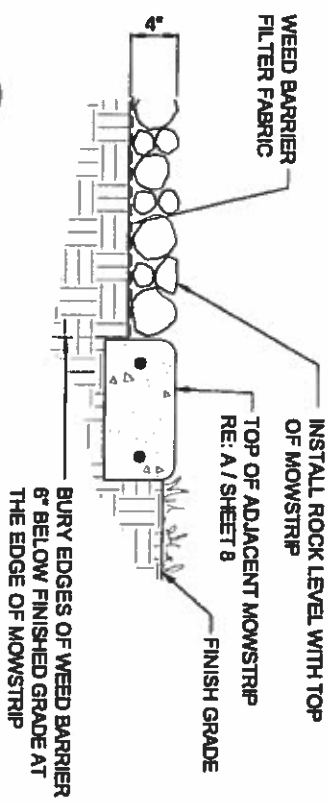

**C DECORATIVE ROCK SECTION**  
SCALE: N.T.S.

**KILLEEN GATEWAY MONUMENT AT S.H. 195**  
KILLEEN, TEXAS

3-25-15

**LANDSCAPE DETAILS**

NO.	REV.	DESCRIPTION	DATE	BY
1				
2				

Texas Department of Transportation  
2015

DAVID C. BALDWIN  
INCORPORATED

NO.	REV.	DESCRIPTION	DATE	BY
1				
2				

LANDSCAPE ARCHITECTURE PLAN  
NO. 15  
DATE: 08/31/15

**ITEM 192 LANDSCAPE PLANTING MAINTENANCE REQUIREMENTS**

After completion of the project installation, as shown in the plans and approved, begin maintenance activities for a period of 90 calendar days as described in ITEM 192.3.15. Payment in accordance with ITEM 192.5. is subject to completion of all scheduled maintenance activities, timeline may also be suspended for failure to complete scheduled maintenance activities. All maintenance work is incidental and is not paid for separately unless otherwise shown on plans. Reference Item 170, 192 of the Texas Standard Specifications for Construction and Maintenance of Highways, Streets and Bridges 2014 for specifications, dimensions, volumes and measurements that are not shown. Notify Engineer prior to each site visit, determination of the completeness of work will be done in the presence of the engineer some day as work activity.

DESCRIPTION OF WORK	TIMELINE (Days)																	
	0	30	60	90														
192.3.15.1. WATERING (See PLANTING AND ESTABLISHMENT SHEET 1 OF 4, VEGETATIVE WATERING SCHEDULE FOR TREES, SHRUBS, VINES)	✓	✓	✓	✓	✓	✓	✓	✓	✓	✓	✓	✓	✓	✓	✓	✓	✓	✓
192.3.15.2. MOWING, TRIMMING, AND EDGING (6" mow width ground bed preparation areas unless otherwise shown on plans)			✓															
192.3.15.3. PLANT BASIN, BED, AND WORKSITE MAINTENANCE (Includes keeping all inlets within or near the bed preparation areas free of debris, litter and compost)	✓	✓	✓	✓	✓	✓	✓	✓	✓	✓	✓	✓	✓	✓	✓	✓	✓	✓
192.3.15.4. PLANT SUPPORTS (Remove plant stakes and all appurtenances within last 10 days of this schedule unless this item 192 maintenance period is followed by Item 193 establishment period, or as directed.)																		
192.3.15.5. PRUNING	✓																	
192.3.15.6. INSECT, DISEASE, AND ANIMAL INSPECTION AND TREATMENT	✓	✓	✓	✓	✓	✓	✓	✓	✓	✓	✓	✓	✓	✓	✓	✓	✓	✓
192.3.15.7. LITTER AND DEBRIS COLLECTION AND DISPOSAL	✓	✓	✓	✓	✓	✓	✓	✓	✓	✓	✓	✓	✓	✓	✓	✓	✓	✓
192.3.15.8. TREE TRUNK WRAP AND PROTECTION GUARD REMOVAL AND DISPOSAL (Not applicable)																		
192.3.15.9. PLANT REPLACEMENT		✓																
IRRIGATION SYSTEM (Only when Item 170 Irrigation System or a temporary irrigation system is part of the contract, see IRRIGATION DETAILS AND MATERIALS SHEET 1 OF 3 GUARANTEE AND ACCEPTANCE)	✓	✓	✓	✓	✓	✓	✓	✓	✓	✓	✓	✓	✓	✓	✓	✓	✓	✓

Remove any materials damaged by actions described in Item 7.18.1. Removal and disposal of damaged materials is incidental to Item 192. Contractor may be reimbursed for plant replacement in accordance with Item 7.18.1. This is not a reimbursable repair.

✓ Work required during defined period of timeline.

  
**Texas Department of Transportation**
  
 WACO DISTRICT

**PLANTING AND ESTABLISHMENT**
  
**SHEET 1 OF 2**

FILE#	160	FEDERAL PROJECT NUMBER	MAINTENANCE
STATE	TEXAS	SHEET	16
COUNTY	BELL	CONTROL SECT	02
DIST	0836	JOB	059
NO		SH	195

STD K-4

**ITEM 193 LANDSCAPE ESTABLISHMENT REQUIREMENTS**

After completion of the Item 192 maintenance period, as shown in the plans and approved, begin Item 193 establishment activities for a period of 12 months. Reference Item 193 of the Texas Standard Specifications for Construction and Maintenance of Highways, Streets and Bridges 2014 for specifications, dimensions, volumes and measurements that are not shown. All establishment work is paid for separately in accordance with Item 193 unless otherwise shown on plans. Notify Engineer prior to each site visit, determination of the completeness of work will be done in the presence of the engineer some day as work activity.

**DESCRIPTION OF WORK**

**TIMELINE (Days)**

	0	30	60	90	120	150	180	210	240	270	300	330	365
193.3.1. PRUNING		1 8 15 22 30 37 45 52 60 67 75 82 90 97 105 112 120 127 135 142 150 157 165 172 180 187 195 202 210 217 225 232 240 247 255 262 270 277 285 292 300 307 315 322 330 337 345 354 365	✓	✓	✓	✓	✓	✓	✓	✓	✓	✓	✓
193.3.2. INSECT, DISEASE, AND ANIMAL CONTROL		✓	✓	✓	✓	✓	✓	✓	✓	✓	✓	✓	✓
193.3.3. FERTILIZATION (General, all-purpose fertilizer)		✓	✓	✓	✓	✓	✓	✓	✓	✓	✓	✓	✓
193.3.4. MULCHING, PLANT BASIN, AND PLANT BED MAINTENANCE (Includes keeping all inlets within or near the bed preparation areas free of debris, litter and compost)		✓	✓	✓	✓	✓	✓	✓	✓	✓	✓	✓	✓
193.3.5. MOWING, TRIMMING, AND EDGING (6' mow width around bed preparation areas unless otherwise shown on plans. Includes areas around any structures within the outer limits adjacent to roadways, of the bed preparation areas)		✓	✓	✓	✓	✓	✓	✓	✓	✓	✓	✓	✓
193.3.6. STAKING, GUYING, AND BRACING OF PLANTS (Remove plant stakes and all appurtenances unless otherwise directed by engineer)													✓
193.3.2. PLANT REPLACEMENT						✓							
193.3.3. VEGETATIVE WATERING (See PLANTING AND ESTABLISHMENT SHEET 1 OF 4 VEGETATIVE WATERING SCHEDULE FOR TREES, SHRUBS, VINES)		✓	✓	✓	✓	✓	✓	✓	✓	✓	✓	✓	✓
193.3.4. IRRIGATION SYSTEM OPERATION AND MAINTENANCE (IF APPLICABLE)		✓	✓	✓	✓	✓	✓	✓	✓	✓	✓	✓	✓
LITTER AND DEBRIS COLLECTION AND DISPOSAL (Collect litter and debris within the bed preparation areas and designated mowing limits. Dispose of litter and debris as directed)		✓	✓	✓	✓	✓	✓	✓	✓	✓	✓	✓	✓

\* Remove any materials damaged by actions described in Item 7, 18.1. Removal and disposal of damaged materials is incidental to Item 193. ✓ = Work required during defined period of timeline.

**Texas Department of Transportation**  
 WACO DISTRICT

**PLANTING AND ESTABLISHMENT**  
 SHEET 2 OF 2

STATE:	TEXAS	FEDERAL PROJECT NUMBER:		SHEET:	17
COUNTY:	BELL	CONTROL SECT:	083B-02	JOB:	HIGHWAY
FILED:	193	DATE:	08-31-09	BY:	SM

STD-K-4

**SITE DESCRIPTION**

**PROJECT LIMITS:**

CSJ 0836-02-0691 On SH 195 @ South  
Killeen City Limits

**LOCATION MAPS:**

Refer to title sheet for project location map.

**PROJECT DESCRIPTION:**

CSJ 0836-02-0691  
Construction of Scenic Enhancement  
Consisting of Gateway Monument and Landscape

**MAJOR SOIL DISTURBING ACTIVITIES:**

The major soil disturbing activities for this project will consist of excavation, embankment, grading and construction of proposed culvert and roadway.

TOTAL PROJECT AREA:	1.08 AC
TOTAL AREA TO BE DISTURBED:	1.08 AC

**EXISTING CONDITION OF SOIL & VEGETATIVE COVER AND % OF EXISTING VEGETATIVE COVER:**

CSJ 0836-02-0691  
The predominant soil type is Lewisville Silty Clay and Ferruginous association.  
Vegetative cover is in good condition with 90-95% coverage.

**NAME OF RECEIVING WATERS:**

CSJ 0836-02-0691  
Project runoff drains into Stream Segment 1216 (Lampasas River) of the Brazos River Basin.

**EROSION AND SEDIMENT CONTROLS**

**SOIL STABILIZATION PRACTICES:**

- TEMPORARY SEEDING
- PERMANENT PLANTING, SOODING, OR SEEDING
- SOIL RETENTION BLANKET
- NATURAL BARRIERS OR BUFFER ZONES
- MULCHING
- PRESERVATION OF NATURAL RESOURCES

OTHER: TR 150000, Part III, Section 5, 2 Stabilization of disturbed areas must, if a minimum, be initiated immediately whenever any clearing, grading, excavating, or other earth disturbing activities have permanently ceased on any portion of the site, or temporarily ceased on any portion of the site and will not resume for a period exceeding 14 calendar days. Temporary stabilization must be completed no more than 14 calendar days after initiation of soil stabilization measures, and final stabilization must be achieved prior to termination of permit coverage.

**STRUCTURAL PRACTICES:**

- SILT FENCES
- HAY BALES
- SANDBAG OR ROCK BERM
- DIVERSION, INTERCEPTOR, OR PERIMETER DIKES
- DIVERSION DIKE AND SMALE COMBINATIONS
- PIPE SLOPE DRAINS
- PAVED FLOWERS
- ROCK BEDDING AT CONSTRUCTION EXIT
- TIMBER MATTING AT CONSTRUCTION EXIT
- CHANNEL LINERS
- SEDIMENT TRAPS
- SEDIMENT BASINS
- STORM INLET SEDIMENT TRAP
- STONE OUTLET STRUCTURES
- CURBS AND GUTTERS
- STORM SENSERS
- VELOCITY CONTROL DEVICES

**OTHER:**

**NARRATIVE - SEQUENCE OF CONSTRUCTION (STORM WATER MANAGEMENT) ACTIVITIES:**

1. Preserve existing vegetative cover as much as possible.
2. Install temporary sediment control fencing, rock berms and other items as shown on plans prior to any soil disturbing activities.
3. Construct proposed monument, construct and perform and perform any necessary excavation, embankment and grading.
4. Place permanent seeding as shown in the plans and as directed.

**STORM WATER MANAGEMENT:**

An integral part of the SWPPP for this project includes the EPIC Sheet, Item 506, Waco District Notice of the US Notice, Waco District Typical Additions for Best Management Practices, Form 2118 TADOT Inspection Form, Contractor daily inspection forms, miscellaneous general notes on environmental requirements, TADOT EC Standard, 2014 Standard Specifications, TADOT roadway design drawings, SWPPP design and working map drawing, Site Manager Data Base, EMS Slope Gate Inspections and the Waco District environmental folders. The requirements of the TADOT EMS will be fully implemented including training requirements for Contractors and TADOT staff.

**STORM WATER POLLUTION PREVENTION PLAN PERMIT POSTING**

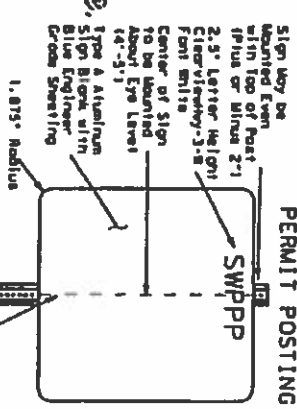

Approved by: *Audrey M. McPeck*  
3/31/2015  
82730

**OTHER EROSION AND SEDIMENT CONTROLS:**

**MAINTENANCE:** All erosion and sediment best management practices (BMPs) will be maintained in good working order per the environmental notes, details and standards included on part of the project plans and contract documents. BMPs will be made of the earliest possible date, but no later than seven calendar days after the inspection report has been completed and immediately after the ground has dried sufficiently to allow equipment access. BMPs damaged by the Contractor will be repaired or replaced immediately. The installation and repair of BMPs of creeks and outfalls will be given priority.

**INSPECTIONS:**

TADOT Form 2118 Inspections to support TR8150000 and 404 permits will be conducted on a seven day interval on the same day of the week, until permits are terminated. The Contractor will provide daily BMP inspection reports on work days. Slope Gate Inspections and other BMP Inspections will be conducted by the District and Area Office Staff based on requirements of the TADOT Environmental Management System (EMS).

**WASTE MATERIALS:**

Any waste materials generated during construction will be disposed of in accordance with existing Federal, state, and local laws.

**HAZARDOUS WASTE (INCLUDING SPILL REPORTING):**

At a minimum, any products in the following categories are considered to be hazardous: fuels, lubricating products, abrasives, or concrete curing compounds and any additives. In the event of a spill which may be hazardous, clean-up will be done in accordance with federal, state, and local regulations. The Contractor will maintain a list of all chemicals and wastes required for the project, including chemicals used by sub-contractors, and will implement written spill prevention and clean-up plans.

**SANITARY WASTE:**

Sanitary waste from portable units will be collected by a licensed sanitary waste management contractor.

**OFF SITE VEHICLE TRACKING:**

- HAUL ROADS DAMPENED FOR DUST CONTROL
- LOADED HAUL TRUCKS TO BE COVERED WITH TARP/ULIN
- EXCESS DIRT ON ROAD REMOVED DAILY
- STABILIZED CONSTRUCTION ENTRANCE

**REMARKS:**

Diurnal erosion, siltation, and haul roads will be constructed in a manner that will minimize and control the amount of sediment that may enter receiving waters. Disposal areas will not be located in any wetland, waterbody or streambed. Construction staging area and vehicle maintenance area will be constructed by the contractor in a manner to minimize the runoff pollutants.

Furnish one SWPP permit posting sign and sign support as detailed on the SWPP Sheet. Install this sign in a location selected by the Engineer. The sign and support should be removed upon completion of the project and is the property of the Contractor. The purchase of the sign and support, installation, relocation if determined necessary by the Engineer and removal or project end will be subsidiary to Item 506.

Sedimentation Basins - Since the area disturbed is less than 10 acres, per outfall location, a sedimentation basin is not required.

Texas Department of Transportation  
Waco District Office  
Advanced Project Development  
100 South Loop Drive  
Maco Texas, 76704-2858

Sign on Post or 6' or Sign  
Approved by: *Audrey M. McPeck*  
3/31/2015  
82730

**WACO DISTRICT  
STORM WATER POLLUTION  
PREVENTION PLAN  
(SW3P)**







# City of Killeen

## Legislation Details

---

**File #:** RS-15-016    **Version:** 1    **Name:** US190-FM2410-Rosewood Change Order #37  
**Type:** Resolution    **Status:** Resolutions  
**File created:** 4/30/2015    **In control:** City Council Workshop  
**On agenda:** 5/19/2015    **Final action:**  
**Title:** Consider a memorandum/resolution authorizing Change Order No. 37 with James Construction Group, LLC to the US 190/FM 2410/Rosewood Drive project.  
**Sponsors:** Public Works Department, Transportation Division  
**Indexes:** US190-Rosewood-FM2410  
**Code sections:**  
**Attachments:** [Council Memorandum](#)  
[Change Order](#)

Date	Ver.	Action By	Action	Result
------	------	-----------	--------	--------



## CITY COUNCIL MEMORANDUM

### AGENDA ITEM

**AUTHORIZE CHANGE ORDER NO. 37 TO THE US 190/FM 2410/ROSEWOOD DRIVE PASS-THROUGH FINANCING CONTRACT WITH JAMES CONSTRUCTION GROUP, LLC.**

### ORIGINATING DEPARTMENT

**PUBLIC WORKS - TRANSPORTATION DIVISION**

### BACKGROUND INFORMATION

On January 8, 2013 (CCM/R 13-001R), the City Council awarded a construction contract to James Construction Group, LLC for the Pass Through Financing (PTF) Project, US 190/FM 2410/Rosewood Drive. This project includes the construction of an overpass at the intersection of US 190 and Rosewood Drive, the widening of FM 2410, and the construction of Rosewood Drive from US 190 to Fawn Drive.

### DISCUSSION/CONCLUSION

Change Order No. 37 is needed in order to compensate the contractor for the eastbound main lanes detour. The detour has become inadequate to carry the heavy loads and heavy traffic volumes. It has been repaired many times because of this past winter's harsher weather conditions. The decision was made to overlay the roadway to minimize the inconvenience to the travelling public because of multiple lane closures to the roadway, necessitated by continuing pavement failures. This approach also provided for increased safety, minimizing future failures and improving rideability.

### FISCAL IMPACT

Change Order No. 37 will increase the expenditure for the Project in the Pass-Thru Finance US 190/FM 2410/Rosewood Drive, General Obligation Bonds, US 190/FM 2410/Rosewood Drive Account #341-3490-800.58-23. The total cost of the change is a net increase of \$81,923.78 for an updated total contract price of \$22,430,593.78, a cumulative 2.18% increase to the original contract.

### RECOMMENDATION

Staff recommends that the City Council authorize the Change Order No. 37 with James Construction Group, LLC increasing the cost of the contract by \$81,923.78.

# CHANGE ORDER

No. 37

DATE OF ISSUANCE 04/16/2015

EFFECTIVE DATE \_\_\_\_\_

OWNER: City Of Killeen  
 CONTRACTOR: James Construction Group, LLC.  
 Contract: Bid No. 13-06  
 TxDOT Project: PTF 1102 (054) ~ US 190 @ Rosewood Drive  
 TxDOT Control No.: 0231-03-129  
 ENGINEER's Contract No. \_\_\_\_\_  
 ENGINEER: \_\_\_\_\_

You are directed to make the following changes in the Contract Documents:

**Description:** Provide for repair and overlay of the East Bound Main Lanes Detour.

**Reason for Change Order:**

The East Bound Main Lanes Detour has become inadequate to carry the heavy loads and heavy traffic volumes. To minimize future repairs and provide for an acceptable rideability, it was decided to overlay the detour.

Existing unit bid pricing was used for HMAC (Ty B) PG 70-22 and Work Zone Pavement Markings Non-Removable. Item 9036-001 Pavement Repair Milling was created to compensate the sub-contractor for milling the additional pavement repairs needed; the item will be paid as per contractor invoice. There were no markups by the Prime Contractor. Labor rates and markups for the sub-contractor were as allowed for in contract documents. Equipment rates were documented by those shown in the Rental Rate Blue Book.

Attachments: Change Order Drawings and Pricing Estimate for proposed work

CHANGE IN CONTRACT PRICE:
Original Contract Price \$ <u>21,952,775.21</u>
Net Increase (Decrease) from previous Change Orders No. <u>1</u> to <u>36</u> : \$ <u>395,894.79</u>
Contract Price prior to this Change Order: \$ <u>22,348,670.00</u>
Net increase (decrease) of this Change Order: \$ <u>81,923.78</u>
Contract Price with all approved Change Orders: \$ <u>22,430,593.78</u>

CHANGE IN CONTRACT TIMES:
Original Contract Times: Substantial Completion: _____ Ready for final payment: _____ (days or dates)
Net change from previous Change Orders No. ___ to No. ___: Substantial Completion: _____ Ready for final payment: _____ (days)
Contract Times prior to this Change Order: Substantial Completion: _____ Ready for final payment: _____ (days or dates)
Net increase (decrease) this Change Order: Substantial Completion: _____ Ready for final payment: _____ (days)
Contract Times with all approved Change Orders: Substantial Completion: _____ Ready for final payment: _____ (days or dates)

**RECOMMENDED:**

**APPROVED:**

**ACCEPTED:**

By: \_\_\_\_\_  
ENGINEER (Authorized Signature)

By: \_\_\_\_\_  
OWNER (Authorized Signature)

By: \_\_\_\_\_  
CONTRACTOR (Authorized Signature)

Date: \_\_\_\_\_  
EJCDC 1910-8-B (1996 Edition)

Date: \_\_\_\_\_

Date: \_\_\_\_\_



# City of Killeen

## Legislation Details

---

**File #:** RS-15-017    **Version:** 1    **Name:** US 190/FM 2410/Rosewood Dr PTF Change Order #38

**Type:** Resolution    **Status:** Resolutions

**File created:** 5/4/2015    **In control:** City Council Workshop

**On agenda:** 5/19/2015    **Final action:**

**Title:** Consider a memorandum/resolution authorizing Change Order No. 38 with James Construction Group, LLC to the US 190/FM 2410/Rosewood Drive project.

**Sponsors:** Public Works Department, Transportation Division

**Indexes:**

**Code sections:**

**Attachments:** [Council Memorandum](#)  
[Change Order](#)

Date	Ver.	Action By	Action	Result
------	------	-----------	--------	--------

## **CITY COUNCIL MEMORANDUM**

### **AGENDA ITEM**

**AUTHORIZE CHANGE ORDER NO. 38 TO THE US 190/FM 2410/ROSEWOOD DRIVE PASS-THROUGH FINANCING CONTRACT WITH JAMES CONSTRUCTION GROUP, LLC.**

### **ORIGINATING DEPARTMENT**

**PUBLIC WORKS/TRANSPORTATION**

### **BACKGROUND INFORMATION**

On January 8, 2013 (CCM/R 13-001R), the City Council awarded a construction contract to James Construction Group, LLC for the Pass Through Financing (PTF) Project, US 190/FM 2410/Rosewood Drive. This project includes the construction of an overpass at the intersection of US 190 and Rosewood Drive, the widening of FM 2410, and the construction of Rosewood Drive from US 190 to Fawn Drive.

### **DISCUSSION/CONCLUSION**

Change Order No. 38 is intended to replace the intermediate layer of pavement on the US 190 main lanes. The porous friction course (PFC) surface mix is not appropriate for placement on roadways that have barrier and curb and gutter on the outside pavement edges. This does not allow water to drain from the pavement. The PFC is being replaced with a stone matrix mix that directs surface drainage of rainwater into existing drainage structures.

### **FISCAL IMPACT**

Change Order No. 38 will decrease the expenditure for the Project in the Pass-Thru Finance US 190/FM 2410/Rosewood Drive, General Obligation Bonds, US 190/FM 2410/Rosewood Drive Account #341-3490-800.58-23. The total cost of the change is a net decrease of \$107,342.92 for an updated total contract price of \$22,323,250.86 or a cumulative 1.69% increase to the original contract.

### **RECOMMENDATION**

City staff recommends that the City Council authorize the Change Order No. 38 with James Construction Group, LLC decreasing the cost of the contract by \$107,342.92.

# CHANGE ORDER

No. 38

DATE OF ISSUANCE 05/1/2015

EFFECTIVE DATE \_\_\_\_\_

OWNER: City Of Killeen  
 CONTRACTOR: James Construction Group, LLC.  
 Contract: Bid No. 13-06  
 TxDOT Project: PTF 1102 (054) ~ US 190 @ Rosewood Drive  
 TxDOT Control No.: 0231-03-129  
 ENGINEER's Contract No. \_\_\_\_\_  
 ENGINEER: \_\_\_\_\_

You are directed to make the following changes in the Contract Documents:

**Description:** Replace Item 342-2002-002 PFC (Asphalt) PG 76-22 and item 342-2006-002 PFC (Aggregate) (PG 76 Mix) (SAC A) with Item 346-2026 STONE-MTRX-ASPH SMA-F (SAC A) (PG76-22). Also, modify planned quantity of Item 3224-2027 D-GR HMA (QCQA) Ty C SAC-B PG 70-22 and 346-2006-002 Stone Matrix Asphalt SMA-C SAC-B PG 76-22.

**Reason for Change Order:**

The Porous Friction Course (PFC) surface mix is not appropriate for placement on roadways that have barrier and curb and gutter on the outside pavement edges. This does not allow water to drain from the pavement. The PFC is being replaced with a Stone Matrix Mix that provides surface drainage of rainwater into existing drainage structures. The substitution allows the use of a Dense Graded Hot Mix Asphalt Concrete for the intermediate layer of pavement.

Attachments: Change Order Pricing Estimate for proposed work.

CHANGE IN CONTRACT PRICE:
Original Contract Price \$ <u>21,952,775.21</u>
Net Increase (Decrease) from previous Change Orders No. <u>1</u> to <u>37</u> : \$ <u>477,818.57</u>
Contract Price prior to this Change Order: \$ <u>22,430,593.78</u>
Net increase (decrease) of this Change Order: \$ <u>&lt;107,342.92&gt;</u>
Contract Price with all approved Change Orders: \$ <u>22,323,250.86</u>

CHANGE IN CONTRACT TIMES:
Original Contract Times: Substantial Completion: _____ Ready for final payment: _____ (days or dates)
Net change from previous Change Orders No. <u>   </u> to No. <u>   </u> : Substantial Completion: _____ Ready for final payment: _____ (days)
Contract Times prior to this Change Order: Substantial Completion: _____ Ready for final payment: _____ (days or dates)
Net increase (decrease) this Change Order: Substantial Completion: _____ Ready for final payment: _____ (days)
Contract Times with all approved Change Orders: Substantial Completion: _____ Ready for final payment: _____ (days or dates)

**RECOMMENDED:**

**APPROVED:**

**ACCEPTED:**

By: \_\_\_\_\_  
ENGINEER (Authorized Signature)

By: \_\_\_\_\_  
OWNER (Authorized Signature)

By: \_\_\_\_\_  
CONTRACTOR (Authorized Signature)

Date: \_\_\_\_\_  
EJCDC 1910-8-B (1996 Edition)

Date: \_\_\_\_\_

Date: \_\_\_\_\_



# City of Killeen

## Legislation Details

---

**File #:** RS-15-018    **Version:** 1    **Name:** Onion Road Area Water Line Project  
**Type:** Resolution    **Status:** Resolutions  
**File created:** 4/30/2015    **In control:** City Council Workshop  
**On agenda:** 5/19/2015    **Final action:**  
**Title:** Consider a memorandum/resolution authorizing the award of a professional services agreement with Kasberg, Patrick & Associates, LP to design the Onion Road Area Water Line Project.  
**Sponsors:** Engineering, Public Works Department, Water & Sewer  
**Indexes:**  
**Code sections:**  
**Attachments:** [Council Memorandum Agreement](#)

Date	Ver.	Action By	Action	Result
------	------	-----------	--------	--------

## CITY COUNCIL MEMORANDUM

### AGENDA ITEM

**Award a Professional Services Agreement to Kasberg, Patrick & Associates, LP to Design the Onion Road Area Water Line Project**

### ORIGINATING DEPARTMENT

**Public Works - Water & Sewer Division**

### BACKGROUND INFORMATION

The 2012 Water and Wastewater Master Plan includes the replacement of a 4-inch water line with an 8-inch water line along Onion Road between Stagecoach Road and Rio Grande Court (Project 4W). Concurrent to this project, City staff determined the need to upsize the adjoining small diameter water lines along Love Road, Grove Drive, and Loop Road. This up-sizing of the water lines is necessary to support future growth and development in the southeastern part of the City. This area was identified in the 2012 Master Plan as having low pressures during peak hour demands and low fire flow availability.

### DISCUSSION/CONCLUSION

Kasberg, Patrick & Associates (KPA) is on the City's prequalified list for engineering services and has extensive experience with the design of water lines. Their proposal includes a final design, bidding documents, and construction administration services necessary for the construction of this project. After negotiating what City staff believes to be a fair and reasonable price for KPA's engineering service, City staff recommends approval of the proposal to design the Onion Road Area Water Line Project for a total amount of \$119,905.00.

### FISCAL IMPACT

Funding for this project is available in the amount of \$119,905.00 through Account Number 386-3495-800.54-84 of the 2012 Water & Sewer Bond.

### RECOMMENDATION

Recommend that the City Council authorize the City Manager to enter into an agreement with KPA for a professional services agreement for the design and contract administration of the Onion Road Area Water Line Project in the amount of \$119,905.00, and that the City Manager be expressly authorized to execute any and all change orders within the amounts set by state and local law.

This document has important legal consequences; consultation with an attorney is encouraged with respect to its use or modification. This document should be adapted to the particular circumstances of the contemplated Project and the Controlling Law.

**STANDARD FORM OF AGREEMENT  
BETWEEN OWNER AND ENGINEER  
FOR  
PROFESSIONAL SERVICES**

*Prepared by*

**ENGINEERS JOINT CONTRACT DOCUMENTS COMMITTEE**

and

Issued and Published Jointly By

PROFESSIONAL ENGINEERS IN PRIVATE PRACTICE  
*a practice division of the*  
NATIONAL SOCIETY OF PROFESSIONAL ENGINEERS

---

AMERICAN CONSULTING ENGINEERS COUNCIL

---

AMERICAN SOCIETY OF CIVIL ENGINEERS

This Agreement has been prepared for use with the Standard General Conditions of the Construction Contract (No. 1910-8, 1996 Edition) of the Engineers Joint Contract Documents Committee. Their provisions are interrelated, and a change in one may necessitate a change in the other. For guidance in the preparation of Supplementary Conditions, see Guide to the Preparation of Supplementary Conditions (No. 1910-17) (1996 Edition). For guidance on the completion and use of this Agreement, see EJCDC Users Guide, No. 1910-50.



Copyright ©1996 National Society of Professional Engineers  
1420 King Street, Alexandria, VA 22314

American Consulting Engineers Council  
1015 15th Street N.W., Washington, DC 20005

American Society of Civil Engineers  
345 East 47th Street, New York, NY 10017

**TABLE OF CONTENTS**

**Page**

ARTICLE 1 - SERVICES OF ENGINEER..... 2  
    1.01 Scope ..... 2

ARTICLE 2 - OWNER’S RESPONSIBILITIES ..... 2  
    2.01 General ..... 2

ARTICLE 3 - TIMES FOR RENDERING SERVICES..... 2  
    3.01 General ..... 2  
    3.02 Suspension..... 2

ARTICLE 4 - PAYMENTS TO ENGINEER..... 2  
    4.01 Methods of Payment for Services and Reimbursable Expenses of ENGINEER ..... 2  
    4.02 Other Provisions Concerning Payments ..... 2

ARTICLE 5 - OPINIONS OF COST ..... 3  
    5.01 Opinions of Probable Construction Cost ..... 3  
    5.02 Designing to Construction Cost Limit ..... 3  
    5.03 Opinions of Total Project Costs ..... 3

ARTICLE 6 - GENERAL CONSIDERATIONS ..... 3  
    6.01 Standards of Performance ..... 3  
    6.02 Authorized Project Representatives ..... 4  
    6.03 Design without Construction Phase Services ..... 4  
    6.04 Use of Documents ..... 4  
    6.05 Insurance ..... 5  
    6.06 Termination ..... 5  
    6.07 Controlling Law ..... 6  
    6.08 Successors, Assigns, and Beneficiaries ..... 6  
    6.09 Hazardous Environmental Condition ..... 6  
    6.10 Allocation of Risks ..... 7  
    6.11 Notices ..... 7  
    6.12 Survival ..... 7  
    6.13 Severability ..... 7  
    6.14 Waiver ..... 7  
    6.15 Headings ..... 8

ARTICLE 7 - DEFINITIONS ..... 8  
    7.01 Defined Terms ..... 8

ARTICLE 8 - EXHIBITS AND SPECIAL PROVISIONS..... 10  
    8.01 Exhibits Included..... 10  
    8.02 Total Agreement..... 11

STANDARD FORM OF AGREEMENT  
BETWEEN OWNER AND ENGINEER  
FOR  
PROFESSIONAL SERVICES

THIS IS AN AGREEMENT effective as of \_\_\_\_\_ (“Effective Date”) between  
the CITY OF KILLEEN (“OWNER”) and Kasberg, Patrick & Associates, LP (“ENGINEER”).

OWNER intends to design and construct an 8-inch water main along Onion Road between Stan Schlueter and Stagecoach Road  
and 6-in water mains along Love Road from Onion Road to Cunningham Road, along Grove Drive from Stagecoach Road to  
Onion Road and along Loop Road from Onion Road to Stagecoach Road. (“Project”)

OWNER and ENGINEER in consideration of their mutual covenants as set forth herein agree as follows:

## ARTICLE 1 - SERVICES OF ENGINEER

---

### 1.01 Scope

A. ENGINEER shall provide the Basic and Additional Services set forth herein and in Exhibit A.

B. Upon this Agreement becoming effective, ENGINEER is authorized to begin Basic Services as set forth in Exhibit A.

C. If authorized by OWNER, ENGINEER shall furnish Resident Project Representative(s) with duties, responsibilities and limitations of authority as set forth in Exhibit D.

## ARTICLE 2 - OWNER'S RESPONSIBILITIES

---

### 2.01 General

A. OWNER shall have the responsibilities set forth herein and in Exhibit B.

## ARTICLE 3 - TIMES FOR RENDERING SERVICES

---

### 3.01 General

A. ENGINEER's services and compensation under this Agreement have been agreed to in anticipation of the orderly and continuous progress of the Project through completion. Unless specific periods of time or specific dates for providing services are specified in this Agreement, ENGINEER's obligation to render services hereunder will be for a period which may reasonably be required for the completion of said services.

B. If in this Agreement specific periods of time for rendering services are set forth or specific dates by which services are to be completed are provided, and if such periods of time or dates are changed through no fault of ENGINEER, the rates and amounts of compensation provided for herein shall be subject to equitable adjustment. If OWNER has requested changes in the scope, extent, or character of the Project, the time of performance of ENGINEER's services shall be adjusted equitably.

C. For purposes of this Agreement the term "day" means a calendar day of 24 hours.

### 3.02 Suspension

A. If OWNER fails to give prompt written authorization to proceed with any phase of services after

completion of the immediately preceding phase, or if ENGINEER's services are delayed through no fault of ENGINEER, ENGINEER may, after giving seven days written notice to OWNER, suspend services under this Agreement.

B. If ENGINEER's services are delayed or suspended in whole or in part by OWNER, or if ENGINEER's services are extended by Contractor's actions or inactions for more than 90 days through no fault of ENGINEER, ENGINEER shall be entitled to equitable adjustment of rates and amounts of compensation provided for elsewhere in this Agreement to reflect, reasonable costs incurred by ENGINEER in connection with, among other things, such delay or suspension and reactivation and the fact that the time for performance under this Agreement has been revised.

## ARTICLE 4 - PAYMENTS TO ENGINEER

---

### 4.01 Methods of Payment for Services and Reimbursable Expenses of ENGINEER

A. *For Basic Services.* OWNER shall pay ENGINEER for Basic Services performed or furnished under Exhibit A, Part 1, as set forth in Exhibit C.

B. *For Additional Services.* OWNER shall pay ENGINEER for Additional Services performed or furnished under Exhibit A, Part 2, as set forth in Exhibit C.

C. *For Reimbursable Expenses.* In addition to payments provided for in paragraphs 4.01.A and 4.01.B, OWNER shall pay ENGINEER for Reimbursable Expenses incurred by ENGINEER and ENGINEER's Consultants as set forth in Exhibit C.

### 4.02 Other Provisions Concerning Payments

A. *Preparation of Invoices.* Invoices will be prepared in accordance with ENGINEER's standard invoicing practices and will be submitted to OWNER by ENGINEER, unless otherwise agreed. The amount billed in each invoice will be calculated as set forth in Exhibit C.

B. *Payment of Invoices.* Invoices are due and payable within 30 days of receipt. If OWNER fails to make any payment due ENGINEER for services and expenses within 30 days after receipt of ENGINEER's invoice therefor, the amounts due ENGINEER will be increased at the rate of 1.0% per month (or the maximum rate of interest permitted by law, if less) from said thirtieth day. In addition, ENGINEER may, after giving seven days written notice to OWNER, suspend services under this Agreement until ENGINEER has been paid in full all amounts due for services, expenses, and other related charges. Payments will be credited first to interest and then to principal.

C. *Disputed Invoices.* In the event of a disputed or contested invoice, only that portion so contested may be withheld from payment, and the undisputed portion will be paid.

D. *Payments Upon Termination.*

1. In the event of any termination under paragraph 6.06, ENGINEER will be entitled to invoice OWNER and will be paid in accordance with Exhibit C for all services performed or furnished and all Reimbursable Expenses incurred through the effective date of termination.

2. In the event of termination by OWNER for convenience or by ENGINEER for cause, ENGINEER, in addition to invoicing for those items identified in subparagraph 4.02.D.1, shall be entitled to invoice OWNER and shall be paid a reasonable amount for services and expenses directly attributable to termination, both before and after the effective date of termination, such as reassignment of personnel, costs of terminating contracts with ENGINEER's Consultants, and other related close-out costs, using methods and rates for Additional Services as set forth in Exhibit C. Engineer Shall not incur additional expenses after receipt of notice of termination, and shall make reasonable efforts to minimize costs.

E. *Records of ENGINEER's Costs.* Records of ENGINEER's costs pertinent to ENGINEER's compensation under this Agreement shall be kept in accordance with generally accepted accounting practices. To the extent necessary to verify ENGINEER's charges and upon OWNER's timely request, copies of such records will be made available to OWNER at cost.

F. *Legislative Actions.* In the event of legislative actions after the Effective Date of the Agreement by any level of government that impose taxes, fees, or costs on ENGINEER's services or other costs in connection with this Project or compensation therefor, such new taxes, fees, or costs shall be invoiced to and paid by OWNER as a Reimbursable Expense to which a Factor of 1.0 shall be applied. Should such taxes, fees, or costs be imposed, they shall be in addition to ENGINEER's estimated total compensation.

**ARTICLE 5 - OPINIONS OF COST**

---

**5.01 Opinions of Probable Construction Cost**

A. ENGINEER's opinions of probable Construction Cost provided for herein are to be made on the basis of ENGINEER's experience and qualifications and represent

ENGINEER's best judgment as an experienced and qualified professional generally familiar with the industry. However, since ENGINEER has no control over the cost of labor, materials, equipment, or services furnished by others, or over the Contractor's methods of determining prices, or over competitive bidding or market conditions, ENGINEER cannot and does not guarantee that proposals, bids, or actual Construction Cost will not vary from opinions of probable Construction Cost prepared by ENGINEER. If OWNER wishes greater assurance as to probable Construction Cost, OWNER shall employ an independent cost estimator as provided in Exhibit B.

**5.02 Designing to Construction Cost Limit**

A. If a Construction Cost limit is established between OWNER and ENGINEER, such Construction Cost limit and a statement of ENGINEER's rights and responsibilities with respect thereto will be specifically set forth in Exhibit F, "Construction Cost Limit," to this Agreement.

**5.03 Opinions of Total Project Costs**

A. ENGINEER assumes no responsibility for the accuracy of opinions of Total Project Costs.

**ARTICLE 6 - GENERAL CONSIDERATIONS**

---

**6.01 Standards of Performance**

A. The standard of care for all professional engineering and related services performed or furnished by ENGINEER under this Agreement will be the care and skill ordinarily used by members of ENGINEER's profession practicing under similar circumstances at the same time and in the same locality. ENGINEER makes no warranties, express or implied, under this Agreement or otherwise, in connection with ENGINEER's services.

B. ENGINEER shall be responsible for the technical accuracy of its services and documents resulting therefrom, and OWNER shall not be responsible for discovering deficiencies therein. ENGINEER shall correct such deficiencies without additional compensation except to the extent such action is directly attributable to deficiencies in OWNER-furnished information.

C. ENGINEER shall perform or furnish professional engineering and related services in all phases of the Project to which this Agreement applies. ENGINEER shall serve as OWNER's prime professional for the Project. ENGINEER may employ such ENGINEER's Consultants as ENGINEER deems necessary to assist in the performance or furnishing of the services. ENGINEER shall not be required to employ any ENGINEER's Consultant unacceptable to ENGINEER.

D. ENGINEER and OWNER shall comply with applicable Laws or Regulations and OWNER-mandated standards. This Agreement is based on these requirements as of its Effective Date. Changes to these requirements after the Effective Date of this Agreement may be the basis for modifications to OWNER's responsibilities or to ENGINEER's scope of services, times of performance, or compensation.

E. OWNER shall be responsible for, and ENGINEER may rely upon, the accuracy and completeness of all requirements, programs, instructions, reports, data, and other information furnished by OWNER to ENGINEER pursuant to this Agreement. ENGINEER may use such requirements, reports, data, and information in performing or furnishing services under this Agreement.

F. OWNER shall make decisions and carry out its other responsibilities in a timely manner and shall bear all costs incident thereto so as not to delay the services of ENGINEER.

G. Prior to the commencement of the Construction Phase, OWNER shall notify ENGINEER of any variations from the language indicated in Exhibit E, "Notice of Acceptability of Work," or of any other notice or certification that ENGINEER will be requested to provide to OWNER or third parties in connection with the Project. OWNER and ENGINEER shall reach agreement on the terms of any such requested notice or certification, and OWNER shall authorize such Additional Services as are necessary to enable ENGINEER to provide the notices or certifications requested.

H. ENGINEER shall not be required to sign any documents, no matter by whom requested, that would result in the ENGINEER's having to certify, guarantee or warrant the existence of conditions whose existence the ENGINEER cannot ascertain. OWNER agrees not to make resolution of any dispute with the ENGINEER or payment of any amount due to the ENGINEER in any way contingent upon the ENGINEER's signing any such certification.

I. During the Construction Phase, ENGINEER shall not supervise, direct, or have control over Contractor's work, nor shall ENGINEER have authority over or responsibility for the means, methods, techniques, sequences, or procedures of construction selected by Contractor, for safety precautions and programs incident to the Contractor's work in progress, nor for any failure of Contractor to comply with Laws and Regulations applicable to Contractor's furnishing and performing the Work.

J. ENGINEER neither guarantees the performance of any Contractor nor assumes responsibility for any

Contractor's failure to furnish and perform the Work in accordance with the Contract Documents.

K. ENGINEER shall not be responsible for the acts or omissions of any Contractor(s), subcontractor or supplier, or of any of the Contractor's agents or employees or any other persons (except ENGINEER's own employees) at the Site or otherwise furnishing or performing any of the Contractor's work; or for any decision made on interpretations or clarifications of the Contract Documents given by OWNER without consultation and advice of ENGINEER.

L. The General Conditions for any construction contract documents prepared hereunder are to be the "Standard General Conditions of the Construction Contract" as prepared by the Engineers Joint Contract Documents Committee (Document No. 1910-8, 1996 Edition) unless both parties mutually agree to use other General Conditions as specifically referenced in Exhibit H.

#### **6.02 Authorized Project Representatives**

A. Contemporaneous with the execution of this Agreement, ENGINEER and OWNER shall designate specific individuals to act as ENGINEER's and OWNER's representatives with respect to the services to be performed or furnished by ENGINEER and responsibilities of OWNER under this Agreement. Such individuals shall have authority to transmit instructions, receive information, and render decisions relative to the Project on behalf of each respective party.

#### **6.03 Design without Construction Phase Services**

A. Should OWNER provide Construction Phase services with either OWNER's representatives or a third party, ENGINEER's Basic Services under this Agreement will be considered to be completed upon completion of the Final Design Phase or Bidding or Negotiating Phase as outlined in Exhibit A.

B. It is understood and agreed that if ENGINEER's Basic Services under this Agreement do not include Project observation, or review of the Contractor's performance, or any other Construction Phase services, and that such services will be provided by OWNER, then OWNER assumes all responsibility for interpretation of the Contract Documents and for construction observation or review and waives any claims against the ENGINEER that may be in any way connected thereto.

#### **6.04 Use of Documents**

A. All Documents are instruments of service in respect to this Project, and ENGINEER shall retain an ownership and property interest therein (including the right of reuse at

the discretion of the ENGINEER) whether or not the Project is completed.

B. Copies of OWNER-furnished data that may be relied upon by ENGINEER are limited to the printed copies (also known as hard copies) that are delivered to the ENGINEER pursuant to Exhibit B. Files in electronic media format of text, data, graphics, or of other types that are furnished by OWNER to ENGINEER are only for convenience of ENGINEER. Any conclusion or information obtained or derived from such electronic files will be at the user's sole risk.

C. Copies of Documents that may be relied upon by OWNER are limited to the printed copies (also known as hard copies) that are signed or sealed by the ENGINEER. Files in electronic media format of text, data, graphics, or of other types that are furnished by ENGINEER to OWNER are only for convenience of OWNER. Any conclusion or information obtained or derived from such electronic files will be at the user's sole risk.

D. Because data stored in electronic media format can deteriorate or be modified inadvertently or otherwise without authorization of the data's creator, the party receiving electronic files agrees that it will perform acceptance tests or procedures within 60 days, after which the receiving party shall be deemed to have accepted the data thus transferred. Any errors detected within the 60-day acceptance period will be corrected by the party delivering the electronic files. ENGINEER shall not be responsible to maintain documents stored in electronic media format after acceptance by OWNER.

E. When transferring documents in electronic media format, ENGINEER makes no representations as to long term compatibility, usability, or readability of documents resulting from the use of software application packages, operating systems, or computer hardware differing from those used by ENGINEER at the beginning of this Project.

F. OWNER may make and retain copies of Documents for information and reference in connection with use on the Project by OWNER. Such Documents are not intended or represented to be suitable for reuse by OWNER or others on extensions of the Project or on any other project. Any such reuse or modification without written verification or adaptation by ENGINEER, as appropriate for the specific purpose intended, will be at OWNER's sole risk and without liability or legal exposure to ENGINEER or to ENGINEER's Consultants. OWNER shall indemnify and hold harmless ENGINEER and ENGINEER's Consultants from all claims, damages, losses, and expenses, including attorneys' fees arising out of or resulting therefrom.

G. If there is a discrepancy between the electronic files and the hard copies, the hard copies govern.

H. Any verification or adaptation of the Documents for extensions of the Project or for any other project will entitle ENGINEER to further compensation at rates to be agreed upon by OWNER and ENGINEER.

#### **6.05 Insurance**

A. ENGINEER shall procure and maintain insurance as set forth in Exhibit G, "Insurance."

B. OWNER shall procure and maintain insurance as set forth in Exhibit G, "Insurance." OWNER shall cause ENGINEER and ENGINEER's Consultants to be listed as additional insureds on any general liability or property insurance policies carried by OWNER which are applicable to the Project.

C. OWNER shall require Contractor to purchase and maintain general liability and other insurance as specified in the Contract Documents and to cause ENGINEER and ENGINEER's Consultants to be listed as additional insureds with respect to such liability and other insurance purchased and maintained by Contractor for the Project

D. OWNER and ENGINEER shall each deliver to the other certificates of insurance evidencing the coverages indicated in Exhibit G. Such certificates shall be furnished prior to commencement of ENGINEER's services and at renewals thereafter during the life of the Agreement.

E. All policies of property insurance shall contain provisions to the effect that ENGINEER's and ENGINEER's Consultants' interests are covered and that in the event of payment of any loss or damage the insurers will have no rights of recovery against any of the insureds or additional insureds thereunder.

F. At any time, OWNER may request that ENGINEER, at OWNER's sole expense, provide additional insurance coverage, increased limits, or revised deductibles that are more protective than those specified in Exhibit G. If so requested by OWNER, with the concurrence of ENGINEER, and if commercially available, ENGINEER shall obtain and shall require ENGINEER's Consultants to obtain such additional insurance coverage, different limits, or revised deductibles for such periods of time as requested by OWNER, and Exhibit G will be supplemented to incorporate these requirements.

#### **6.06 Termination**

A. The obligation to provide further services under this Agreement may be terminated:

1. *For cause,*

a. By either party upon 30 days written notice in the event of substantial failure by the other party to perform in accordance with the terms hereof through no fault of the terminating party.

b. By ENGINEER:

1) upon seven days written notice if ENGINEER believes that ENGINEER is being requested by OWNER to furnish or perform services contrary to ENGINEER's responsibilities as a licensed professional; or

2) upon seven days written notice if the ENGINEER's services for the Project are delayed or suspended for more than 90 days for reasons beyond ENGINEER's control.

3) ENGINEER shall have no liability to OWNER on account of such termination.

c. Notwithstanding the foregoing, this Agreement will not terminate as a result of such substantial failure if the party receiving such notice begins, within seven days of receipt of such notice, to correct its failure to perform and proceeds diligently to cure such failure within no more than 30 days of receipt thereof; provided, however, that if and to the extent such substantial failure cannot be reasonably cured within such 30 day period, and if such party has diligently attempted to cure the same and thereafter continues diligently to cure the same, then the cure period provided for herein shall extend up to, but in no case more than, 60 days after the date of receipt of the notice.

2. *For convenience,*

a. By OWNER effective upon the receipt of notice by ENGINEER.

B. The terminating party under paragraphs 6.06.A.1 or 6.06.A.2 may set the effective date of termination at a time up to 30 days later than otherwise provided to allow ENGINEER to demobilize personnel and equipment from the Site, to complete tasks whose value would otherwise be lost, to prepare notes as to the status of completed and uncompleted tasks, and to assemble Project materials in orderly files.

#### **6.07 Controlling Law**

A. This Agreement is to be governed by the law of the State of Texas and venue shall be in Bell County.

#### **6.08 Successors, Assigns, and Beneficiaries**

A. OWNER and ENGINEER each is hereby bound and the partners, successors, executors, administrators and legal representatives of OWNER and ENGINEER (and to the extent permitted by paragraph 6.08.B the assigns of OWNER and ENGINEER) are hereby bound to the other party to this Agreement and to the partners, successors, executors, administrators and legal representatives (and said assigns) of such other party, in respect of all covenants, agreements and obligations of this Agreement.

B. Neither OWNER nor ENGINEER may assign, sublet, or transfer any rights under or interest (including, but without limitation, moneys that are due or may become due) in this Agreement without the written consent of the other, except to the extent that any assignment, subletting, or transfer is mandated or restricted by law. Unless specifically stated to the contrary in any written consent to an assignment, no assignment will release or discharge the assignor from any duty or responsibility under this Agreement.

C. Unless expressly provided otherwise in this Agreement:

1. Nothing in this Agreement shall be construed to create, impose, or give rise to any duty owed by OWNER or ENGINEER to any Contractor, Contractor's subcontractor, supplier, other individual or entity, or to any surety for or employee of any of them.

2. All duties and responsibilities undertaken pursuant to this Agreement will be for the sole and exclusive benefit of OWNER and ENGINEER and not for the benefit of any other party. The OWNER agrees that the substance of the provisions of this paragraph 6.08.C shall appear in the Contract Documents.

#### **6.09 Hazardous Environmental Condition**

A. OWNER represents to Engineer that to the best of its knowledge a Hazardous Environmental Condition does not exist.

B. OWNER has disclosed to the best of its knowledge to ENGINEER the existence of all Asbestos, PCB's, Petroleum, Hazardous Waste, or Radioactive Material located at or near the Site, including type, quantity and location.

C. If a Hazardous Environmental Condition is encountered or alleged, ENGINEER shall have the obligation to notify OWNER and, to the extent of applicable Laws and Regulations, appropriate governmental officials.

D. It is acknowledged by both parties that ENGINEER's scope of services does not include any services related to a Hazardous Environmental Condition. In



the event ENGINEER or any other party encounters a Hazardous Environmental Condition, ENGINEER may, at its option and without liability for consequential or any other damages, suspend performance of services on the portion of the Project affected thereby until OWNER: (i) retains appropriate specialist consultant(s) or contractor(s) to identify and, as appropriate, abate, remediate, or remove the Hazardous Environmental Condition; and (ii) warrants that the Site is in full compliance with applicable Laws and Regulations.

E. OWNER acknowledges that ENGINEER is performing professional services for OWNER and that ENGINEER is not and shall not be required to become an "arranger," "operator," "generator," or "transporter" of hazardous substances, as defined in the Comprehensive Environmental Response, Compensation, and Liability Act of 1990 (CERCLA), which are or may be encountered at or near the Site in connection with ENGINEER's activities under this Agreement.

F. If ENGINEER's services under this Agreement cannot be performed because of a Hazardous Environmental Condition, the existence of the condition shall justify ENGINEER's terminating this Agreement for cause on 30 days notice.

## **6.10 Allocation of Risks**

### **A. Indemnification**

1. To the fullest extent permitted by law, ENGINEER shall indemnify and hold harmless OWNER, OWNER's officers, directors, partners, and employees from and against any and all costs, losses, and damages (including but not limited to all fees and charges of engineers, architects, attorneys, and other professionals, and all court or arbitration or other dispute resolution costs) caused solely by the negligent acts or omissions of ENGINEER or ENGINEER's officers, directors, partners, employees, and ENGINEER's Consultants in the performance and furnishing of ENGINEER's services under this Agreement.

2. To the fullest extent permitted by law, OWNER shall indemnify and hold harmless ENGINEER, ENGINEER's officers, directors, partners, employees, and ENGINEER's Consultants from and against any and all costs, losses, and damages (including but not limited to all fees and charges of engineers, architects, attorneys, and other professionals, and all court or arbitration or other dispute resolution costs) caused solely by the negligent acts or omissions of OWNER or OWNER's officers, directors, partners, employees, and OWNER's consultants with respect to this Agreement or the Project.

3. In addition to the indemnity provided under paragraph 6.10.A.2 of this Agreement, and to the fullest extent permitted by law, OWNER shall indemnify and hold harmless ENGINEER and its officers, directors, partners, employees, and ENGINEER's Consultants from and against all costs, losses, and damages (including but not limited to all fees and charges of engineers, architects, attorneys, and other professionals, and all court or arbitration or other dispute resolution costs) caused by, arising out of or resulting from a Hazardous Environmental Condition, provided that (i) any such cost, loss, or damage is attributable to bodily injury, sickness, disease, or death, or to injury to or destruction of tangible property (other than completed Work), including the loss of use resulting therefrom, and (ii) nothing in this paragraph 6.10.A.4. shall obligate OWNER to indemnify any individual or entity from and against the consequences of that individual's or entity's own negligence or willful misconduct.

4. The indemnification provision of paragraph 6.10.A.1 is subject to and limited by the provisions agreed to by OWNER and ENGINEER in Exhibit I, "Allocation of Risks," if any.

## **6.11 Notices**

A. Any notice required under this Agreement will be in writing, addressed to the appropriate party at its address on the signature page and given personally, or by registered or certified mail postage prepaid, or by a commercial courier service. All notices shall be effective upon the date of receipt.

## **6.12 Survival**

A. All express representations, indemnifications, or limitations of liability included in this Agreement will survive its completion or termination for any reason.

## **6.13 Severability**

A. Any provision or part of the Agreement held to be void or unenforceable under any Laws or Regulations shall be deemed stricken, and all remaining provisions shall continue to be valid and binding upon OWNER and ENGINEER, who agree that the Agreement shall be reformed to replace such stricken provision or part thereof with a valid and enforceable provision that comes as close as possible to expressing the intention of the stricken provision.

## **6.14 Waiver**

A. Non-enforcement of any provision by either party shall not constitute a waiver of that provision, nor shall it

affect the enforceability of that provision or of the remainder of this Agreement.

## 6.15 Headings

A. The headings used in this Agreement are for general reference only and do not have special significance.

## ARTICLE 7 - DEFINITIONS

---

### 7.01 Defined Terms

A. Wherever used in this Agreement (including the Exhibits hereto) and printed with initial or all capital letters, the terms listed below have the meanings indicated, which are applicable to both the singular and plural thereof:

1. *Addenda*--Written or graphic instruments issued prior to the opening of Bids which clarify, correct, or change the Bidding Documents.

2. *Additional Services*--The services to be performed for or furnished to OWNER by ENGINEER in accordance with Exhibit A, Part 2 of this Agreement.

3. *Agreement*--This "Standard Form of Agreement between OWNER and ENGINEER for Professional Services," including those Exhibits listed in Article 8 hereof.

4. *Application for Payment*--The form acceptable to ENGINEER which is to be used by Contractor in requesting progress or final payments for the completion of its Work and which is to be accompanied by such supporting documentation as is required by the Contract Documents.

5. *Asbestos*--Any material that contains more than one percent asbestos and is friable or is releasing asbestos fibers into the air above current action levels established by the United States Occupational Safety and Health Administration.

6. *Basic Services*--The services to be performed for or furnished to OWNER by ENGINEER in accordance with Exhibit A, Part 1, of this Agreement.

7. *Bid*--The offer or proposal of the bidder submitted on the prescribed form setting forth the prices for the Work to be performed.

8. *Bidding Documents*--The advertisement or invitation to Bid, instructions to bidders, the Bid form and attachments, the Bid bond, if any, the proposed Contract Documents, and all Addenda, if any.

9. *Change Order*--A document recommended by ENGINEER, which is signed by Contractor and OWNER to authorize an addition, deletion or revision in the Work, or an adjustment in the Contract Price or the Contract Times, issued on or after the Effective Date of the Construction Agreement.

10. *Construction Agreement*--The written instrument which is evidence of the agreement, contained in the Contract Documents, between OWNER and Contractor covering the Work.

11. *Construction Contract*--The entire and integrated written agreement between the OWNER and Contractor concerning the Work.

12. *Construction Cost*--The cost to OWNER of those portions of the entire Project designed or specified by ENGINEER. Construction Cost does not include costs of services of ENGINEER or other design professionals and consultants, cost of land, rights-of-way, or compensation for damages to properties, or OWNER's costs for legal, accounting, insurance counseling or auditing services, or interest and financing charges incurred in connection with the Project, or the cost of other services to be provided by others to OWNER pursuant to Exhibit B of this Agreement. Construction Cost is one of the items comprising Total Project Costs.

13. *Contract Documents*--Documents that establish the rights and obligations of the parties engaged in construction and include the Construction Agreement between OWNER and Contractor, Addenda (which pertain to the Contract Documents), Contractor's Bid (including documentation accompanying the Bid and any post-Bid documentation submitted prior to the notice of award) when attached as an exhibit to the Construction Agreement, the notice to proceed, the bonds, appropriate certifications, the General Conditions, the Supplementary Conditions, the Specifications and the Drawings as the same are more specifically identified in the Construction Agreement, together with all Written Amendments, Change Orders, Work Change Directives, Field Orders, and ENGINEER's written interpretations and clarifications issued on or after the Effective Date of the Construction Agreement. Approved Shop Drawings and the reports and drawings of subsurface and physical conditions are not Contract Documents.

14. *Contract Price*--The moneys payable by OWNER to Contractor for completion of the Work in accordance with the Contract Documents and as stated in the Construction Agreement.

15. *Contract Times*--The numbers of days or the dates stated in the Construction Agreement to: (i) achieve Substantial Completion, and (ii) complete the Work so that it is ready for final payment as evidenced by ENGINEER's written recommendation of final payment.

16. *Contractor*--An individual or entity with whom OWNER enters into a Construction Agreement.

17. *Correction Period*--The time after Substantial Completion during which Contractor must correct, at no cost to OWNER, any Defective Work, normally one year after the date of Substantial Completion or such longer period of time as may be prescribed by Laws or Regulations or by the terms of any applicable special guarantee or specific provision of the Contract Documents.

18. *Defective*--An adjective which, when modifying the word Work, refers to Work that is unsatisfactory, faulty, or deficient, in that it does not conform to the Contract Documents, or does not meet the requirements of any inspection, reference standard, test, or approval referred to in the Contract Documents, or has been damaged prior to ENGINEER's recommendation of final payment.

19. *Documents*--Data, reports, Drawings, Specifications, Record Drawings, and other deliverables, whether in printed or electronic media format, provided or furnished in appropriate phases by ENGINEER to OWNER pursuant to this Agreement.

20. *Drawings*--That part of the Contract Documents prepared or approved by ENGINEER which graphically shows the scope, extent, and character of the Work to be performed by Contractor. Shop Drawings are not Drawings as so defined.

21. *Effective Date of the Construction Agreement*--The date indicated in the Construction Agreement on which it becomes effective, but if no such date is indicated, it means the date on which the Construction Agreement is signed and delivered by the last of the two parties to sign and deliver.

22. *Effective Date of the Agreement*--The date indicated in this Agreement on which it becomes effective, but if no such date is indicated, it means the date on which the Agreement is signed and delivered by the last of the two parties to sign and deliver.

23. *ENGINEER's Consultants*--Individuals or entities having a contract with ENGINEER to furnish services with respect to this Project as ENGINEER's independent professional associates, consultants,

subcontractors, or vendors. The term ENGINEER includes ENGINEER's Consultants.

24. *Field Order*--A written order issued by ENGINEER which directs minor changes in the Work but which does not involve a change in the Contract Price or the Contract Times.

25. *General Conditions*--That part of the Contract Documents which sets forth terms, conditions, and procedures that govern the Work to be performed or furnished by Contractor with respect to the Project.

26. *Hazardous Environmental Condition*--The presence at the Site of Asbestos, PCB's, Petroleum, Hazardous Waste, or Radioactive Materials in such quantities or circumstances that may present a substantial danger to persons or property exposed thereto in connection with the Work.

27. *Hazardous Waste*--The term Hazardous Waste shall have the meaning provided in Section 1004 of the Solid Waste Disposal Act (42 USC Section 6903) as amended from time to time.

28. *Laws and Regulations; Laws or Regulations*--Any and all applicable laws, rules, regulations, ordinances, codes, standards, and orders of any and all governmental bodies, agencies, authorities, and courts having jurisdiction.

29. *PCB's*--Polychlorinated biphenyls.

30. *Petroleum*--Petroleum, including crude oil or any fraction thereof which is liquid at standard conditions of temperature and pressure (60 degrees Fahrenheit and 14.7 pounds per square inch absolute), such as oil, petroleum, fuel oil, oil sludge, oil refuse, gasoline, kerosene, and oil mixed with other non-Hazardous Waste and crude oils.

31. *Radioactive Materials*--Source, special nuclear, or byproduct material as defined by the Atomic Energy Act of 1954 (42 USC Section 2011 et seq.) as amended from time to time.

32. *Record Drawings*--The Drawings as issued for construction on which the ENGINEER, upon completion of the Work, has shown changes due to Addenda or Change Orders and other information which ENGINEER considers significant based on record documents furnished by Contractor to ENGINEER and which were annotated by Contractor to show changes made during construction.

33. *Reimbursable Expenses*--The expenses incurred directly by ENGINEER in connection with the

performing or furnishing of Basic and Additional Services for the Project for which OWNER shall pay ENGINEER as indicated in Exhibit C.

34. *Resident Project Representative*--The authorized representative of ENGINEER, if any, assigned to assist ENGINEER at the Site during the Construction Phase. The Resident Project Representative will be ENGINEER's agent or employee and under ENGINEER's supervision. As used herein, the term Resident Project Representative includes any assistants of Resident Project Representative agreed to by OWNER. The duties and responsibilities of the Resident Project Representative are as set forth in Exhibit D.

35. *Samples*--Physical examples of materials, equipment, or workmanship that are representative of some portion of the Work and which establish the standards by which such portion of the Work will be judged.

36. *Shop Drawings*--All drawings, diagrams, illustrations, schedules, and other data or information which are specifically prepared or assembled by or for Contractor and submitted by Contractor to ENGINEER to illustrate some portion of the Work.

37. *Site*--Lands or areas indicated in the Contract Documents as being furnished by OWNER upon which the Work is to be performed, rights-of-way and easements for access thereto, and such other lands furnished by OWNER which are designated for use of Contractor.

38. *Specifications*--That part of the Contract Documents consisting of written technical descriptions of materials, equipment, systems, standards, and workmanship as applied to the Work and certain administrative details applicable thereto.

39. *Substantial Completion*--The time at which the Work (or a specified part thereof) has progressed to the point where, in the opinion of ENGINEER, the Work (or a specified part thereof) is sufficiently complete, in accordance with the Contract Documents, so that the Work (or a specified part thereof) can be utilized for the purposes for which it is intended. The terms "substantially complete" and "substantially completed" as applied to all or part of the Work refer to Substantial Completion thereof.

40. *Supplementary Conditions*--That part of the Contract Documents which amends or supplements the General Conditions.

41. *Total Project Costs*--The sum of the Construction Cost, allowances for contingencies, the total costs of services of ENGINEER or other design professionals and consultants, cost of land, rights-of-way, or compensation for damages to properties, or OWNER's costs for legal, accounting, insurance counseling or auditing services, or interest and financing charges incurred in connection with the Project, or the cost of other services to be provided by others to OWNER pursuant to Exhibit B of this Agreement.

42. *Work*--The entire completed construction or the various separately identifiable parts thereof required to be provided under the Contract Documents with respect to this Project. Work includes and is the result of performing or furnishing labor, services, and documentation necessary to produce such construction and furnishing, installing, and incorporating all materials and all equipment into such construction, all as required by the Contract Documents.

43. *Work Change Directive*--A written directive to Contractor issued on or after the Effective Date of the Construction Agreement and signed by OWNER upon recommendation of the ENGINEER, ordering an addition, deletion, or revision in the Work, or responding to differing or unforeseen subsurface or physical conditions under which the Work is to be performed or to emergencies. A Work Change Directive will not change the Contract Price or the Contract Times but is evidence that the parties expect that the change directed or documented by a Work Change Directive will be incorporated in a subsequently issued Change Order following negotiations by the parties as to its effect, if any, on the Contract Price or Contract Times.

44. *Written Amendment*--A written amendment of the Contract Documents signed by OWNER and Contractor on or after the Effective Date of the Construction Agreement and normally dealing with the non-engineering or non-technical rather than strictly construction-related aspects of the Contract Documents.

## **ARTICLE 8 - EXHIBITS AND SPECIAL PROVISIONS**

---

### **8.01 Exhibits Included**

A. Exhibit A, "ENGINEER's Services," consisting of 3 pages.

B. Exhibit B, "OWNER's Responsibilities," consisting of 2 pages.

C. Exhibit C, "Payments to Engineer for Services and Reimbursable Expenses," consisting of 1 page.

D. Exhibit D, "Duties, Responsibilities and Limitations of Authority of Resident Project Representative," consisting of 1 pages.

E. Exhibit E, "Notice of Acceptability of Work," consisting of 2 pages.

F. Exhibit F, "Construction Cost Limit," consisting of 1 page.

G. Exhibit G, "Insurance," consisting of 2 page.

H. Exhibit H, "Special Provisions," consisting of 1 page.

#### **8.02 Total Agreement**

A. This Agreement (consisting of pages 1 to 12 inclusive, together with the Exhibits identified above) constitutes the entire agreement between OWNER and ENGINEER and supersedes all prior written or oral understandings. This Agreement may only be amended, supplemented, modified, or canceled by a duly executed written instrument.

IN WITNESS WHEREOF, the parties hereto have executed this Agreement, the Effective Date of which is indicated on page 1.

OWNER:

City of Killeen

By: Glenn Morrison

Title: City Manager

Date Signed: \_\_\_\_\_

Address for giving notices:

P.O. Box 1329

Killeen, TX 76540-1329

\_\_\_\_\_

\_\_\_\_\_

Designated Representative (paragraph 6.02.A):

Steve Kana, P.E.

Title: Director of Water and Sewer Utilities

Phone Number: 254-501-7623

Facsimile Number: 254-501-6321

E-Mail Address: skana@killeentexas.gov

ENGINEER:

\_\_\_\_\_

By: Rick N. Kasberg, P.E.

Title: President

Date Signed: \_\_\_\_\_

Address for giving notices:

One South Main

Temple, Texas 76501

\_\_\_\_\_

\_\_\_\_\_

Designated Representative (paragraph 6.02.A):

Ginger R. Tolbert, P.E.

Title: Principal

Phone Number: (254) 773-3731

Facsimile Number: (254) 773-6667

E-Mail Address: gtolbert@kpaengineers.com

This is **EXHIBIT A**, consisting of 3 pages, referred to in and part of the **Agreement between OWNER and ENGINEER for Professional Services** dated \_\_\_\_\_, \_\_\_\_\_.

Initial:  
OWNER \_\_\_\_\_  
ENGINEER \_\_\_\_\_

### ENGINEER's Services

Article 1 of the Agreement is amended and supplemented to include the following agreement of the parties. ENGINEER shall provide Basic and Additional Services as set forth below.

#### PART 1 -- BASIC SERVICES

A. ENGINEER shall perform the following tasks:

A1.01 Final Design

- A. Coordinate and Attend Kick off Meeting with City Staff
- B. Obtain and Review water and wastewater record drawings from City.
- C. Request for City to mark existing utilities.
- D. Provide Design survey.
- E. Process design survey, create existing ground surface and illustrate topographical features.
- F. Prepare preliminary alignment (30% Review Set) for water line improvements.
- G. Submit preliminary alignment for review
- H. Incorporate comments.
- I. Prepare Final Plans and Specifications
- J. Prepare Quantity Take-off
- K. Prepare Opinion of Probable Construction Cost
- L. Prepare Bid Schedule.
- M. Provide Review Set to City
- N. Incorporate Comments.
- O. Prepare Bid Documents.
- P. Prepare Advertisement and provide to City.
- Q. Quality Assurance

A1.02 Bidding

- A. Solicit bidders.
- B. Monitor status/number of bidders on plan holders list.
- C. Prepare for and conduct Pre-Bid Conference.
- D. Address contractor questions during bid process.
- E. Prepare addenda as required.
- F. Attend Bid Opening.
- G. Tabulate bids and recommend contract award.
- H. Attend meeting for council award of bid.
- I. Prepare and Distribute "Released for Construction" Drawings.

A1.03 Construction Administration Services

- A. Prepare for and conduct pre-construction conference.
- B. Review submittals for compliance with City standards.
- C. Provide periodic site visits by engineer to observe materials and construction.
- D. Conduct monthly construction meetings.
- E. Address Requests for Information (RFIs)
- F. Review/Prepare pay requests and recommend payment.
- G. Communicate with City Staff regarding project status and schedule.
- H. Prepare change orders as required.
- I. Coordinate tie-ins and abandonment with City Staff.
- J. Conduct final walk through and prepare punch list

K. Prepare Record Drawings and submit to City.

## **PART 2 – ADDITIONAL SERVICES**

### *A2.01 Additional Services Requiring OWNER's Authorization in Advance*

A. If authorized in writing by OWNER, ENGINEER shall furnish or obtain from others Additional Services of the types listed below. These services will be paid for by OWNER as indicated in Article 4 of the Agreement.

1. Preparation of applications and supporting documents (in addition to those furnished under Basic Services) for private or governmental grants, loans or advances in connection with the Project; preparation or review of environmental assessments and impact statements; review and evaluation of the effects on the design requirements for the Project of any such statements and documents prepared by others; and assistance in obtaining approvals of authorities having jurisdiction over the anticipated environmental impact of the Project.

2. Services to make measured drawings of or to investigate existing conditions or facilities, or to verify the accuracy of drawings or other information furnished by OWNER.

3. Services resulting from significant changes in the scope, extent, or character of the portions of the Project designed or specified by ENGINEER or its design requirements including, but not limited to, changes in size, complexity, OWNER's schedule, character of construction, or method of financing; and revising previously accepted studies, reports, Drawings, Specifications, or Contract Documents when such revisions are required by changes in Laws and Regulations enacted subsequent to the Effective Date of this Agreement or are due to any other causes beyond ENGINEER's control.

4. Services resulting from OWNER's request to evaluate additional Study and Report Phase alternative solutions beyond those identified.

5. Services required as a result of OWNER's providing incomplete or incorrect Project information with respect to Exhibit B.

6. Providing renderings or models for OWNER's use.

7. Undertaking investigations and studies including, but not limited to, detailed consideration of operations, maintenance, and overhead expenses; the preparation of feasibility studies, cash flow and economic evaluations, rate schedules, and appraisals; assistance in obtaining financing for the Project; evaluating processes available for licensing, and assisting OWNER in obtaining process licensing; detailed quantity surveys of materials, equipment, and labor; and audits or inventories required in connection with construction performed by OWNER.

8. Furnishing services of ENGINEER's Consultants for other than Basic Services.

9. Services attributable to more prime construction contracts than specified.

10. Services during out-of-town travel required of ENGINEER other than for visits to the Site or OWNER's office.

11. Preparing for, coordinating with, participating in and responding to structured independent review processes, including, but not limited to, construction management, cost estimating, project peer review, value engineering, and constructability review requested by OWNER; and performing or furnishing services required to revise studies, reports, Drawings, Specifications, or other Bidding Documents as a result of such review processes.

12. Preparing additional Bidding Documents or Contract Documents for alternate bids or prices requested by OWNER for the Work or a portion thereof.

13. Determining the acceptability of substitute materials and equipment proposed during the Bidding or Negotiating Phase when substitution prior to the award of contracts is allowed by the Bidding Documents.



14. Assistance in connection with Bid protests, rebidding, or renegotiating contracts for construction, materials, equipment, or services, except when such assistance is required by Exhibit F.
15. Providing construction surveys and staking to enable Contractor to perform its work other than as required under Part A, and any type of property surveys or related engineering services needed for the transfer of interests in real property; and providing other special field surveys.
16. Providing Construction Phase services beyond the Contract Times set forth in Exhibit C.
17. Providing assistance in resolving any Hazardous Environmental Condition in compliance with current Laws and Regulations.
18. Preparing and furnishing to OWNER Record Drawings showing appropriate record information based on Project annotated record documents received from Contractor.
19. Preparation of operation and maintenance manuals.
20. Preparing to serve or serving as a consultant or witness for OWNER in any litigation, arbitration or other dispute resolution process related to the Project.
21. Providing more extensive services required to enable ENGINEER to issue notices or certifications requested by OWNER under paragraph 6.01.G of the Agreement.
22. Other services performed or furnished by ENGINEER not otherwise provided for in this Agreement.

*A2.02 Required Additional Services*

A. ENGINEER shall perform or furnish, without requesting or receiving specific advance authorization from OWNER, the Additional Services of the types listed below. ENGINEER shall advise OWNER in writing promptly after starting any such Additional Services.

1. Services in connection with Work Change Directives and Change Orders to reflect changes requested by OWNER so as to make the compensation commensurate with the extent of the Additional Services rendered.
2. Services in making revisions to Drawings and Specifications occasioned by the acceptance of substitute materials or equipment other than "or-equal" items; and services after the award of the Construction Agreement in evaluating and determining the acceptability of a substitution which is found to be inappropriate for the Project or an excessive number of substitutions.
3. Services resulting from significant delays, changes, or price increases occurring as a direct or indirect result of materials, equipment, or energy shortages.
4. Additional or extended services during construction made necessary by (1) emergencies or acts of God endangering the Work, (2) an occurrence of a Hazardous Environmental Condition, (3) Work damaged by fire or other cause during construction, (4) a significant amount of defective, neglected, or delayed work by Contractor, (5) acceleration of the progress schedule involving services beyond normal working hours, or (6) default by Contractor.
5. Services (other than Basic Services during the Post-Construction Phase) in connection with any partial utilization of any part of the Work by OWNER prior to Substantial Completion.
6. Evaluating an unreasonable claim or an excessive number of claims submitted by Contractor or others in connection with the Work.

This is **EXHIBIT B**, consisting of 2 pages, referred to in and part of the **Agreement between OWNER and ENGINEER for Professional Services** dated \_\_\_\_\_, \_\_\_\_\_.

Initial:

OWNER \_\_\_\_\_

ENGINEER \_\_\_\_\_

**OWNER's Responsibilities**

Article 2 of the Agreement is amended and supplemented to include the following agreement of the parties.

B2.01 In addition to other responsibilities of OWNER as set forth in this Agreement, OWNER shall:

A. Provide ENGINEER with all criteria and full information as to OWNER's requirements for the Project, including design objectives and constraints, space, capacity and performance requirements, flexibility, and expandability, and any budgetary limitations; and furnish copies of all design and construction standards which OWNER will require to be included in the Drawings and Specifications; and furnish copies of OWNER's standard forms, conditions, and related documents for ENGINEER to include in the Bidding Documents, when applicable.

B. Furnish to ENGINEER any other available information pertinent to the Project including reports and data relative to previous designs, or investigation at or adjacent to the Site.

C. Following ENGINEER's assessment of initially-available Project information and data and upon ENGINEER's request, furnish or otherwise make available such additional Project related information and data as is reasonably required to enable ENGINEER to complete its Basic and Additional Services. Such additional information or data would generally include the following:

1. Property descriptions.
2. Zoning, deed, and other land use restrictions.
3. Property, boundary, easement, right-of-way, and other special surveys or data, including establishing relevant reference points.
4. Explorations and tests of subsurface conditions at or contiguous to the Site, drawings of physical conditions in or relating to existing surface or subsurface structures at or contiguous to the Site, or hydrographic surveys, with appropriate professional interpretation thereof.
5. Environmental assessments, audits, investigations and impact statements, and other relevant environmental or cultural studies as to the Project, the Site, and adjacent areas.
6. Data or consultations as required for the Project but not otherwise identified in the Agreement or the Exhibits thereto.

D. Give prompt written notice to ENGINEER whenever OWNER observes or otherwise becomes aware of a Hazardous Environmental Condition or of any other development that affects the scope or time of performance of ENGINEER's services, or any defect or nonconformance in ENGINEER's services or in the work of any Contractor.

E. Authorize ENGINEER to provide Additional Services as set forth in Part 2 of Exhibit A of the Agreement as required.

F. Arrange for safe access to and make all provisions for ENGINEER to enter upon public and private property as required for ENGINEER to perform services under the Agreement.

G. Examine all alternate solutions, studies, reports, sketches, Drawings, Specifications, proposals, and other documents presented by ENGINEER (including obtaining advice of an attorney, insurance counselor, and other advisors or consultants as OWNER deems appropriate with respect to such examination) and render in writing timely decisions pertaining thereto.

H. Provide reviews, approvals, and permits from all governmental authorities having jurisdiction to approve all phases of the Project designed or specified by ENGINEER and such reviews, approvals, and consents from others as may be necessary for completion of each phase of the Project.

I. Provide, as required for the Project:

1. Accounting, bond and financial advisory, independent cost estimating, and insurance counseling services.
2. Legal services with regard to issues pertaining to the Project as OWNER requires, Contractor raises, or ENGINEER reasonably requests.
3. Such auditing services as OWNER requires to ascertain how or for what purpose Contractor has used the moneys paid.
4. Placement and payment for advertisement for Bids in appropriate publications.

J. Advise ENGINEER of the identity and scope of services of any independent consultants employed by OWNER to perform or furnish services in regard to the Project, including, but not limited to, cost estimating, project peer review, value engineering, and constructibility review.

K. Furnish to ENGINEER data as to OWNER's anticipated costs for services to be provided by others for OWNER so that ENGINEER may make the necessary calculations to develop and periodically adjust ENGINEER's opinion of Total Project Costs.

L. If OWNER designates a construction manager or an individual or entity other than, or in addition to, ENGINEER to represent OWNER at the Site, define and set forth as an attachment to this Exhibit B the duties, responsibilities, and limitations of authority of such other party and the relation thereof to the duties, responsibilities, and authority of ENGINEER.

M. If more than one prime contract is to be awarded for the Work designed or specified by ENGINEER, designate a person or entity to have authority and responsibility for coordinating the activities among the various prime Contractors, and define and set forth the duties, responsibilities, and limitations of authority of such individual or entity and the relation thereof to the duties, responsibilities, and authority of ENGINEER as an attachment to this Exhibit B that is to be mutually agreed upon and made a part of this Agreement before such services begin.

N. Attend the pre-bid conference, bid opening, pre-construction conferences, construction progress and other job related meetings, and Substantial Completion and final payment inspections.

O. Provide the services of an independent testing laboratory to perform all inspections, tests, and approvals of Samples, materials, and equipment required by the Contract Documents, or to evaluate the performance of materials, equipment, and facilities of OWNER, prior to their incorporation into the Work with appropriate professional interpretation thereof.

P. Provide inspection or monitoring services by an individual or entity other than ENGINEER (and disclose the identity of such individual or entity to ENGINEER) as OWNER determines necessary to verify:

1. That Contractor is complying with any Laws and Regulations applicable to Contractor's performing and furnishing the Work.
2. That Contractor is taking all necessary precautions for safety of persons or property and complying with any special provisions of the Contract Documents applicable to safety.

Q. Provide ENGINEER with the findings and reports generated by the entities providing services pursuant to paragraphs B2.01.O and P.

This is **EXHIBIT C**, consisting of 1 page, referred to in and part of the **Agreement between OWNER and ENGINEER for Professional Services** dated \_\_\_\_\_, \_\_\_\_\_

Initial:

OWNER \_\_\_\_\_  
ENGINEER \_\_\_\_\_

Payments to ENGINEER for Services and Reimbursable Expenses

Article 4 of the Agreement is amended and supplemented to include the following agreement of the parties:

ARTICLE 4 -- PAYMENTS TO THE ENGINEER

C4.01 *For Basic Services Having A Determined Scope*

A. OWNER shall pay ENGINEER for Basic Services set forth in Exhibit A, except for services of ENGINEER's Resident Project Representative and Post-Construction Phase, services, if any, as follows:

1. Progress payments in the amount of \$119,905.00 based on the following assumed distribution of compensation:

- |                                  |                     |
|----------------------------------|---------------------|
| a. Final Design Phase            | <u>\$91,935.00</u>  |
| b. Bidding and Negotiating Phase | <u>\$ 6,540.00</u>  |
| c. Construction Phase            | <u>\$ 21,430.00</u> |

2. ENGINEER may alter the distribution of compensation between individual phases noted herein to be consistent with services actually rendered, but shall not exceed the total amount unless approved in writing by the OWNER.

3. The amount includes compensation for ENGINEER's services and services of ENGINEER's Consultants, if any. Appropriate amounts have been incorporated to account for labor, overhead, profit, and Reimbursable Expenses.

4. The portion of the amount billed for ENGINEER's services will be based upon ENGINEER's estimate of the proportion of the total services actually completed during the billing period.

5. If more prime contracts are awarded for work designed or specified by ENGINEER for this Project than identified in Exhibit A, the ENGINEER shall be compensated an additional amount to be negotiated; however, in no case shall the amount of compensation exceed eighteen percent (18%) of the Project's estimated construction costs for all Basic Services for each prime contract added.

This is **EXHIBIT D**, consisting of 1 pages, referred to in and part of the **Agreement between OWNER and ENGINEER for Professional Services** dated \_\_\_\_\_, \_\_\_\_\_.

Initial:

OWNER \_\_\_\_\_  
ENGINEER \_\_\_\_\_

**Duties, Responsibilities, and Limitations of Authority of Resident Project Representative**

Paragraph 1.01C of the Agreement is amended and supplemented to include the following agreement of the parties:

NOT APPLICABLE

This is **EXHIBIT E**, consisting of 2 pages, referred to in and part of the **Agreement between OWNER and ENGINEER for Professional Services** dated \_\_\_\_\_.

Initial:  
OWNER \_\_\_\_\_  
ENGINEER \_\_\_\_\_

---

**NOTICE OF ACCEPTABILITY OF WORK**

---

PROJECT: Onion Road Water Line

---

OWNER: City of Killeen

OWNER's Construction Contract Identification: 413-003

EFFECTIVE DATE OF THE CONSTRUCTION AGREEMENT:

CONSTRUCTION CONTRACT DATE:

ENGINEER:

To: **OWNER**

---

And To: **CONTRACTOR**

The undersigned hereby gives notice to the above OWNER and CONTRACTOR that the completed Work furnished and performed by CONTRACTOR under the above Contract is acceptable, expressly subject to the provisions of the related Contract Documents and the terms and conditions set forth on the reverse side hereof.

By: \_\_\_\_\_

Title: \_\_\_\_\_

Dated: \_\_\_\_\_, \_\_\_\_\_

(Reverse side of Notice)

**CONDITIONS OF NOTICE OF ACCEPTABILITY OF WORK**

The Notice of Acceptability of Work ("Notice") on the front side of this sheet is expressly made subject to the following terms and conditions to which all persons who receive said Notice and rely thereon agree:

1. Said Notice is given with the skill and care ordinarily used by members of the engineering profession practicing under similar conditions at the same time and in the same locality.
2. Said Notice reflects and is an expression of the professional judgment of ENGINEER.
3. Said Notice is given as to the best of ENGINEER's knowledge, information, and belief as of the date hereof.
4. Said Notice is based entirely on and expressly limited by the scope of services ENGINEER has been employed by OWNER to perform or furnish during construction of the Project (including observation of the CONTRACTOR's work) under ENGINEER's Agreement with OWNER and under the Construction Contract referenced on the reverse hereof, and applies only to facts that are within ENGINEER's knowledge or could reasonably have been ascertained by ENGINEER as a result of carrying out the responsibilities specifically assigned to ENGINEER under ENGINEER's Agreement with OWNER and the Construction Contract referenced on the reverse hereof.
5. Said Notice is not a guarantee or warranty of CONTRACTOR's performance under the Construction Contract referenced on the reverse hereof nor an assumption of responsibility for any failure of CONTRACTOR to furnish and perform the Work thereunder in accordance with the Contract Documents.

This is **EXHIBIT F**, consisting of 1 page, referred to in and part of the **Agreement between OWNER and ENGINEER for Professional Services** dated \_\_\_\_\_,  
\_\_\_\_\_.

Initial:

OWNER \_\_\_\_\_

ENGINEER \_\_\_\_\_

**Construction Cost Limit**

---

Paragraph 5.02 of the Agreement is amended and supplemented to include the following agreement of the parties:

NOT APPLICABLE



This is **EXHIBIT G**, consisting of 2 pages, referred to in and part of the Agreement between **OWNER** and **ENGINEER** for Professional Services dated \_\_\_\_\_, \_\_\_\_\_.

Initial:  
OWNER \_\_\_\_\_  
ENGINEER \_\_\_\_\_

**Insurance**

---

Paragraph 6.05 of the Agreement is amended and supplemented to include the following agreement of the parties.

G6.05 *Insurance*

A. The limits of liability for the insurance required by paragraph 6.05.A and 6.05.B of the Agreement are as follows:

1. By ENGINEER:

- a. Workers' Compensation: Statutory
- b. Employer's Liability --
  - 1) Each Accident: \$ 500,000
  - 2) Disease, Policy Limit: \$ 500,000
  - 3) Disease, Each Employee: \$ 500,000
- c. General Liability --
  - 1) Each Occurrence (Bodily Injury and Property Damage): \$ 1,000,000
  - 2) General Aggregate: \$ 2,000,000
- d. Excess or Umbrella Liability --
  - 1) Each Occurrence: \$ 4,000,000
  - 2) General Aggregate: \$ 4,000,000
- e. Automobile Liability --
  - 1) Bodily Injury:
    - a) Each Accident \$ \_\_\_\_\_
  - 2) Property Damage:
    - a) Each \$ \_\_\_\_\_

Accident \$ \_\_\_\_\_

[or]

- 1) Combined Single Limit (Bodily Injury and Property Damage):  
Each Accident \$ 500,000

f. Other (specify): On all policies except Workers Compensation and Professional Liability - "City of Killeen is named as Additional Insured on the General Liability and Auto Liability policies."



# CERTIFICATE OF LIABILITY INSURANCE

DATE (MM/DD/YYYY)

6/30/2014

THIS CERTIFICATE IS ISSUED AS A MATTER OF INFORMATION ONLY AND CONFERS NO RIGHTS UPON THE CERTIFICATE HOLDER. THIS CERTIFICATE DOES NOT AFFIRMATIVELY OR NEGATIVELY AMEND, EXTEND OR ALTER THE COVERAGE AFFORDED BY THE POLICIES BELOW. THIS CERTIFICATE OF INSURANCE DOES NOT CONSTITUTE A CONTRACT BETWEEN THE ISSUING INSURER(S), AUTHORIZED REPRESENTATIVE OR PRODUCER, AND THE CERTIFICATE HOLDER.

**IMPORTANT:** If the certificate holder is an ADDITIONAL INSURED, the policy(ies) must be endorsed. If SUBROGATION IS WAIVED, subject to the terms and conditions of the policy, certain policies may require an endorsement. A statement on this certificate does not confer rights to the certificate holder in lieu of such endorsement(s).

<b>PRODUCER</b> McLaughlin Brunson Insurance Agency, LLP 12801 N. Central Expressway Suite 1710 Dallas TX 75243	<b>CONTACT NAME:</b> Brian R Hadar	
	<b>PHONE (A/C, No, Ext):</b> (214) 503-1212	<b>FAX (A/C, No):</b> (214) 503-8899
<b>E-MAIL ADDRESS:</b>		
<b>INSURER(S) AFFORDING COVERAGE</b>		<b>NAIC #</b>
<b>INSURER A:</b> Catlin Insurance Company, Inc.		19518
<b>INSURER B:</b>		
<b>INSURER C:</b>		
<b>INSURER D:</b>		
<b>INSURER E:</b>		
<b>INSURER F:</b>		

**INSURED** (254) 773-3731  
 Kasberg, Patrick & Associates, LP  
 One South Main Street  
 Temple TX 76501

**COVERAGES** **CERTIFICATE NUMBER:** Cert ID 25821 **REVISION NUMBER:**

THIS IS TO CERTIFY THAT THE POLICIES OF INSURANCE LISTED BELOW HAVE BEEN ISSUED TO THE INSURED NAMED ABOVE FOR THE POLICY PERIOD INDICATED. NOTWITHSTANDING ANY REQUIREMENT, TERM OR CONDITION OF ANY CONTRACT OR OTHER DOCUMENT WITH RESPECT TO WHICH THIS CERTIFICATE MAY BE ISSUED OR MAY PERTAIN, THE INSURANCE AFFORDED BY THE POLICIES DESCRIBED HEREIN IS SUBJECT TO ALL THE TERMS, EXCLUSIONS AND CONDITIONS OF SUCH POLICIES. LIMITS SHOWN MAY HAVE BEEN REDUCED BY PAID CLAIMS.

INSR LTR	TYPE OF INSURANCE	ADDL INSR	SUBR WVD	POLICY NUMBER	POLICY EFF (MM/DD/YYYY)	POLICY EXP (MM/DD/YYYY)	LIMITS	
	<b>GENERAL LIABILITY</b> <input type="checkbox"/> COMMERCIAL GENERAL LIABILITY <input type="checkbox"/> CLAIMS-MADE <input type="checkbox"/> OCCUR GEN'L AGGREGATE LIMIT APPLIES PER: <input type="checkbox"/> POLICY <input type="checkbox"/> PRO-JECT <input type="checkbox"/> LOC						EACH OCCURRENCE \$ DAMAGE TO RENTED PREMISES (Ea occurrence) \$ MED EXP (Any one person) \$ PERSONAL & ADV INJURY \$ GENERAL AGGREGATE \$ PRODUCTS - COMP/OP AGG \$	
	<b>AUTOMOBILE LIABILITY</b> <input type="checkbox"/> ANY AUTO <input type="checkbox"/> ALL OWNED AUTOS <input type="checkbox"/> SCHEDULED AUTOS <input type="checkbox"/> HIRED AUTOS <input type="checkbox"/> NON-OWNED AUTOS						COMBINED SINGLE LIMIT (Ea accident) \$ BODILY INJURY (Per person) \$ BODILY INJURY (Per accident) \$ PROPERTY DAMAGE (Per accident) \$	
	<b>UMBRELLA LIAB</b> <input type="checkbox"/> OCCUR <b>EXCESS LIAB</b> <input type="checkbox"/> CLAIMS-MADE DED RETENTION \$						EACH OCCURRENCE \$ AGGREGATE \$	
	<b>WORKERS COMPENSATION AND EMPLOYERS' LIABILITY</b> ANY PROPRIETOR/PARTNER/EXECUTIVE OFFICER/MEMBER EXCLUDED? (Mandatory in NH) <input type="checkbox"/> Y/N If yes, describe under DESCRIPTION OF OPERATIONS below		N/A				WC STATUTORY LIMITS OTH-ER E.L. EACH ACCIDENT \$ E.L. DISEASE - EA EMPLOYEE \$ E.L. DISEASE - POLICY LIMIT \$	
A	<b>Professional Liability</b>	Y	N	AED-209136-0715	7/1/2014	7/1/2015	Per Claim/Annual Aggregate	\$ 2,000,000

**DESCRIPTION OF OPERATIONS / LOCATIONS / VEHICLES** (Attach ACORD 101, Additional Remarks Schedule, if more space is required)  
 The claims made professional liability coverage is the total aggregate limit for all claims presented within the policy period and is subject to a deductible.

<b>CERTIFICATE HOLDER</b>  Master Certificate	<b>CANCELLATION</b>  SHOULD ANY OF THE ABOVE DESCRIBED POLICIES BE CANCELLED BEFORE THE EXPIRATION DATE THEREOF, NOTICE WILL BE DELIVERED IN ACCORDANCE WITH THE POLICY PROVISIONS.
	<b>AUTHORIZED REPRESENTATIVE</b> <i>Brian R Hadar</i>

© 1988-2010 ACORD CORPORATION. All rights reserved.

This is **EXHIBIT H**, consisting of 1 page, referred to in and part of the **Agreement between OWNER and ENGINEER for Professional Services** dated \_\_\_\_\_, \_\_\_\_\_.

Initial:  
OWNER \_\_\_\_\_  
ENGINEER \_\_\_\_\_

Special Provisions

---

No Further Agreements



# City of Killeen

## Legislation Details

---

**File #:** RS-15-019    **Version:** 1    **Name:** Parks Mowing Equipment Lease  
**Type:** Resolution    **Status:** Resolutions  
**File created:** 4/29/2015    **In control:** City Council Workshop  
**On agenda:** 5/19/2015    **Final action:**  
**Title:** Consider a memorandum/resolution authorizing a lease agreement with C&M Golf and Grounds Equipment for Parks and Recreation mowing equipment utilizing the TASB Buy Board.  
**Sponsors:** Community Services Department, Killeen Parks & Recreation  
**Indexes:**  
**Code sections:**  
**Attachments:** [Council Memorandum](#)  
[Equipment Lease](#)

Date	Ver.	Action By	Action	Result
------	------	-----------	--------	--------

## **CITY COUNCIL MEMORANDUM**

### **AGENDA ITEM**

### **LEASE AGREEMENT WITH C&M GOLF AND GROUNDS EQUIPMENT FOR PARKS AND RECREATION MOWING EQUIPMENT**

### **ORIGINATING DEPARTMENT**

**Community Services**

### **BACKGROUND INFORMATION**

Parks and Recreation has utilized a lease program for mowing equipment since 2008. The lease option provides the division with modern equipment without incurring any major maintenance fees. In addition, it allows the division to avoid the significant financial burden that would be incurred in one fiscal year if the equipment were purchased. Instead, the costs are distributed over a thirty-six month period. The current lease, thirteen pieces of equipment provided by C&M Golf and Grounds Equipment, expires on June 30, 2015.

### **DISCUSSION/CONCLUSION**

Because the staff has opted to utilize larger mowers, the proposed lease agreement includes ten pieces of equipment and provides for increased mowing efficiency. Staff has secured pricing for the equipment with C&M through the TASB Buy Board, a purchasing cooperative, satisfying the city's bidding requirements pursuant to Texas Local Government Code section 271.102.

### **FISCAL IMPACT**

Funds in the amount of \$8,901 are available in account 010-3025-425-4410 Hire of Equipment, FY 2014-2015, for the initial three months of the lease. The following thirty-three payments for the lease will be funded from the same account in fiscal years 2015-2016 (\$35,601), 2016-2017 (\$35,601), and 2017-2018 (\$26,701). These funds are budgeted annually via the division's base budget.

### **RECOMMENDATION**

Staff recommends that the City Council authorize the lease of ten pieces of mowing equipment over thirty-six months to C&M Golf and Grounds of Waco, Texas, and that the city manager is expressly authorized to execute any and all change orders within the amounts set by state and local law.



# Master Equipment Lease Agreement

Wells Fargo Financial Leasing, Inc. | 800 Walnut, 4th floor | Des Moines, Iowa 50309 | Phone: 866-336-8382

### Customer Information:

Customer's Full Legal Name ("You" and "Your"):

City of Killeen

Address:

101 North College Street

City/State/Zip Code:

Killeen, TX 76541

Telephone Number:

Federal Tax ID#:

County:

Bell

You acknowledge and agree that this agreement (as amended from time to time, this "Agreement") and each Schedule (defined below) represent the complete and exclusive agreement between You and Us regarding the subject matter herein and therein and supersedes any other oral or written agreements between You and Us regarding such matters. "Schedule" means a schedule, in such form as We may accept in our sole discretion, that may be entered into from time to time by You and Us for a lease transaction pursuant to this Agreement. This Agreement and each Schedule can be changed only by a written agreement between You and Us. Other agreements not stated herein or in a Schedule (including, without limitation, those contained in any purchase order or service agreement between You and the equipment supplier(s) (each a "Supplier")) are not part of a Lease (defined below). This Agreement is not a commitment by Us to enter into any Schedule not currently in effect, and nothing in this Agreement shall impose, or be construed to impose, any obligation upon Us to enter into any proposed Schedule, it being understood that whether We enter into any proposed Schedule shall be a decision solely within Our discretion. To help the government fight the funding of terrorism and money laundering activities, U.S. Federal law requires financial institutions to obtain, verify and record information that identifies each person (individuals or businesses) who opens an account. What this means for You: When You open an account or add any additional service, We will ask You for Your name, address, federal employer identification number and other information that will allow Us to identify You. We may also ask to see other identifying documents.

**1. LEASE OF EQUIPMENT.** Each Schedule executed by You represents Your agreement to lease from Us the personal property listed therein (together with all existing and future accessories, attachments and replacements, the "Equipment") upon the terms stated in such Schedule and this Agreement. Each Schedule and the terms of this Agreement which are incorporated by reference into such Schedule shall constitute a separate and independent contract between You and Us and shall be referred to as a "Lease". In the event of any conflict between the provisions of this Agreement and the provisions of any Schedule, the provisions of the Schedule shall control. Each Schedule is binding on You as of the date You sign it. You agree that after You sign this Agreement or a Schedule, We may insert or correct any information missing in this Agreement or a Schedule, including Your proper legal name, serial numbers and any other information describing the Equipment, and change the Payment shown in a Schedule by up to 15% due to a change in the Equipment or its cost or a tax or payment adjustment.

**2. TERM; AUTOMATIC RENEWAL.** The term of each Lease will begin on the date that the related Schedule is accepted by Us or any later date that We designate (the "Commencement Date") and will continue for the number of months shown on such Schedule (the "Initial Term"). As used herein, "Term" means the term presently in effect at any time, whether it is the Initial Term or a Renewal Term (defined below). **With respect to each Lease, unless You have a \$1.00 Purchase Option as indicated in the related Schedule, You shall notify Us in writing at least 30 days before the end of a Term (the "Notice Period") that you intend to purchase or return the Equipment at the end of such Term or: (a) the applicable Lease will automatically renew for an additional one-month period (a "Renewal Term") and (b) all terms of such Lease will continue to apply.** If You do notify Us in writing within the Notice Period for a given Lease that You intend to purchase or return the related Equipment at the end of the Term of such Lease, then You shall (i) purchase the Equipment by paying the purchase option amount (and all other amounts due hereunder) within 10 days after the end of the Term, or (ii) return the Equipment pursuant to Section 12. For any "Fair Market Value" Purchase Option, the fair market value shall be determined by Us in Our sole but commercially reasonable judgment. **Each Lease is non-cancelable for the full Term.**

**3. UNCONDITIONAL OBLIGATION.** With respect to each Lease, You agree that: (i) We are a separate and independent company from the Suppliers, manufacturer and any other vendor (collectively, "Vendors"), and the Vendors are NOT Our agents; (ii) No representation or warranty by any Vendor is binding on Us, and no Vendor has authority to waive or alter any term of this Agreement or any Schedule; (iii) You, not We, selected the Equipment and the Vendors based on Your own judgment; (iv) Your obligations under each Lease are absolute and unconditional and are not subject to cancellation, reduction or setoff for any reason whatsoever; (v) If You are a party to any maintenance, supplies or other contract with any Vendor, We are NOT a party thereto, such contract is NOT part of any Lease (even though We may, as a convenience to You and a Vendor, bill and collect monies owed by You to such Vendor), and no breach by any Vendor will excuse You from performing Your obligations to Us under any Lease; and (vi) If the Equipment is unsatisfactory or if any Vendor fails to provide any service or fulfill any other obligation to You, You shall not make any claim against Us and shall continue to fully perform under each Lease.

**4. PAYMENTS.** With respect to each Lease, You agree to pay Us an interim rent charge as reasonably calculated by Us for the period from the date the Equipment is delivered to You until the Commencement Date of such Lease. The payment for this interim period will be based on the Payment shown in the related Schedule prorated on a 30 day calendar month and will be added to Your first invoice. Each Payment Period for a given Lease, You agree to pay Us, by the due date set forth on Our invoice to You (i) the Payment due under the related Schedule, and (ii) applicable taxes and other charges provided for in the Lease. Restrictive endorsements on checks will not be binding on Us. All payments received will be applied to past due amounts and to the current amount due in such order as We determine. Any security deposit that You pay under a Lease is non-interest bearing, may be commingled with Our funds, may be applied by Us at any time to cure any default by You, and the unused portion will be returned to You after You have satisfied all of Your obligations under the applicable Lease. If We do not receive a payment in full within ten (10) days of its due date, You shall pay a fee equal to 5% of the amount that is late (or the maximum amount permitted by law if less). You shall pay Us a returned check or non-sufficient funds charge of \$20.00 for any returned or dishonored check or draft.

**5. INDEMNIFICATION.** You shall indemnify and hold Us harmless from and against, any and all claims, actions, damages, liabilities, losses and costs (including but not limited to reasonable attorneys' fees) made against Us, or suffered or incurred by Us, arising directly or indirectly out of, or otherwise relating to, the delivery, installation, possession, ownership, use, loss of use, defect in or malfunction of the Equipment. This obligation shall survive the termination of each Lease. We shall not be liable to You for any damages of any kind, including any liability for consequential damages, arising out of the use of or the inability to use the Equipment.

**6. NO WARRANTIES. WE ARE LEASING THE EQUIPMENT TO YOU "AS IS". WE HAVE NOT MADE AND HEREBY DISCLAIM ANY AND ALL WARRANTIES, EXPRESS OR IMPLIED, ARISING BY APPLICABLE LAW OR OTHERWISE, INCLUDING WITHOUT LIMITATION, THE IMPLIED WARRANTIES OF MERCHANTABILITY AND FITNESS FOR A PARTICULAR PURPOSE.** The parties hereto agree that each Lease is, or shall be treated as, a "finance lease" under Article 2A of the Uniform Commercial Code (the "UCC"). You hereby waive any and all rights and remedies conferred upon You by Article 2A of the UCC. If any Lease is deemed to be a secured transaction, You hereby grant to Us a security interest in the Equipment and all proceeds thereof. You authorize Us to record UCC financing statements to protect Our interests in the Equipment. You may be entitled under Article 2A of the UCC to the promises and warranties (if any) provided to Us by the Suppliers in connection with or as part of the contract (if any) by which We acquire the Equipment, which warranty rights We assign to You for the applicable Term (provided You are not in default). You acknowledge that You are aware of the name of the Supplier of each item of Equipment and You may contact the Suppliers for an accurate and complete statement of those promises and warranties (if any), including any disclaimers and limitations of them or of remedies.

**7. DELIVERY; LOCATION; OWNERSHIP; USE AND MAINTENANCE.** We are not responsible for delivery or installation of the Equipment. You are responsible for Equipment maintenance. You will not remove the Equipment from the Equipment Location specified in a Schedule unless You first get Our permission. You shall give Us reasonable access to the Equipment Location so that We may inspect the Equipment, and You agree to pay Our costs in connection therewith. We will own and have title to the Equipment (excluding any software) during each Lease. You agree that the Equipment is and shall remain personal property and without Our prior written consent, You shall not permit it to become (i) attached to real property, or (ii) subject to liens or encumbrances of any kind. You represent that the Equipment will be used solely for commercial purposes and not for personal, family or household purposes. You will use the Equipment in accordance with all laws, operation manuals, service contracts (if any) and insurance requirements, shall comply with all manufacturer's instructions, specified maintenance programs and warranty requirements, and shall not make any permanent alterations to the Equipment. At Your own cost, You will keep the Equipment in good working order and warrantable condition, ordinary wear and tear excepted, and in compliance with any additional Equipment maintenance and return conditions set forth in the applicable Schedule or any addendum thereto ("Good Condition"). With respect to any Equipment that includes an hour meter/counter ("Meter"), You shall not tamper with, adjust or make the Meter inoperable. You shall keep each such Meter in

BY SIGNING BELOW, CUSTOMER ACKNOWLEDGES RECEIPT OF PAGE 2 OF THIS AGREEMENT AND AGREES TO THE TERMS ON BOTH PAGES 1 & 2

Customer: (Identified above) City of Killeen		Wells Fargo Financial Leasing, Inc. ("We," "Us," "Our" and "Lessor")	
By:	Date: ___ / ___ / ___	By:	Date: ___ / ___ / ___
Print name: Glenn Morrison	Title: City Manager	Print name:	Title:
		Agreement Number:	

Good Condition at all times, shall immediately notify Us if it becomes inoperable, and shall, at Your expense, promptly undertake such repairs as We deem necessary to restore it to Good Condition. In the event an item of Equipment is used in excess of the Included Engine Hours Per Year designated in the Schedule during the applicable Initial Term and any Renewal Term, You shall pay the applicable Excess Charge (per engine hour) set forth in such Schedule for each engine hour in excess of the Included Engine Hours Per Year ("Excess Engine Hours") for such item of Equipment. Upon return of the Equipment, We (or Our agent) will determine Excess Engine Hours based on the actual Meter readings and/or the number of engine hours the Equipment has been used during the Lease. Excess Charges for Excess Engine Hours shall be billed to You as additional rent following Your return of the Equipment.

**8. LOSS; DAMAGE; INSURANCE.** You shall, at all times during each Lease, (i) bear the risk of loss and damage to the Equipment and shall continue performing all Your obligations to Us even if it becomes damaged or suffers a loss, (ii) keep the Equipment insured against all risks of damage and loss ("Property Insurance") in an amount equal to its replacement cost, with Us named as sole "loss payee" (with a lender's loss payable endorsement if required by Lessor or its Assignee), and (iii) carry public liability insurance covering bodily injury and property damage ("Liability Insurance") in an amount acceptable to Us, with Us named as an additional insured thereunder. With respect to each Lease, You have the choice of satisfying these insurance requirements for a given Lease by providing Us with satisfactory evidence of Property and Liability Insurance ("Insurance Proof"), within 30 days of the Commencement Date of such Lease. Such Insurance Proof must provide for at least 30 days prior written notice to Us before it may be cancelled or terminated and must contain other terms satisfactory to Us. If you do not provide Us with Insurance Proof within 30 days of the Commencement Date of a Lease, or if such insurance terminates for any reason, then (a) You agree that We have the right, but not the obligation, to obtain such Property Insurance and/or Liability Insurance in such forms and amounts from an insurer of Our choosing in order to protect Our interests ("Other Insurance"), and (b) You agree that We may charge you a periodic charge for such Other Insurance. This periodic charge will include reimbursement for premiums advanced by Us to purchase Other Insurance, billing and tracking fees, charges for Our processing and related fees associated with the Other Insurance, and a finance charge of up to 18% per annum (or the maximum rate allowed by law if less) on any advances We make for premiums (collectively, the "Insurance Charge"). We and/or one or more of our affiliates and/or agents may receive a portion of the Insurance Charge, which may include a profit. We are not obligated to obtain, and may cancel, Other Insurance at any time without notice to You. Any Other Insurance need not name You as an insured or protect Your interests. The Insurance Charge may be higher than if You obtained Property and Liability Insurance on Your own.

**9. ASSIGNMENT.** You shall not sell, transfer, assign or otherwise encumber (collectively, "Transfer") this Agreement or any Lease, or Transfer or sublease any Equipment, in whole or in part, without Our prior written consent; provided, however, if the Equipment includes any power golf carts, You may rent such cart(s) on a daily or per-round basis to Your patrons at the Equipment Location listed on the applicable Schedule in which case You shall collect from such patrons all sales and use taxes due in connection with such rentals and remit such taxes to the appropriate taxing authorities, and You shall continue performing all Your obligations under the applicable Lease. We may, without notice to You, Transfer Our interests in the Equipment, this Agreement and/or any Lease, in whole or in part, to a third party (an "Assignee"), in which case the Assignee will, to the extent of such Transfer, have all of Our rights and benefits but will not have to perform Our obligations (if any). Any Transfer by Us will not relieve Us of Our obligations under this Agreement or any Lease. You agree not to assert against the Assignee any claim, defense or offset You may have against Us.

**10. TAXES AND OTHER FEES.** You are responsible for all taxes (including, without limitation, sales, use and personal property taxes, excluding only taxes based on Our income), assessments, license and registration fees and other governmental charges relating to this Agreement, each Lease and/or the Equipment (collectively "Governmental Charges"). Sales or use taxes due upfront will be payable over the Initial Term of each Lease, with a finance charge. You authorize Us to pay any Governmental Charges as they become due, and You agree to reimburse Us promptly upon demand for the full amount. You agree to pay Us a fee for Our administration of taxes related to the Equipment leased under each Lease. With respect to each Lease, You also agree to pay Us upon demand (i) for all costs of filing, amending and releasing UCC financing statements, and (ii) a documentation/processing fee in the amount set forth in the related Schedule (or as otherwise agreed to). You also agree to pay Us a fee for additional services We may provide to You at Your request during a Lease. If You so request and We permit the early termination of a Lease, You acknowledge that there may be a cost or charge to You for such privilege. In connection with the expiration or earlier termination of a Lease, You agree to pay Us any Governmental Charges accrued or assessed but not yet due and payable, or Our estimate of such amounts. You agree that the fees and other amounts payable under this Agreement and each Lease may include a profit to Us and/or the Suppliers.

**11. DEFAULT; REMEDIES.** With respect to each Lease, You will be in default if (1) You fail to pay any amount due under any Lease within 15 days of the due date, (2) You breach or attempt to breach any other term, representation or covenant in this Agreement, any Lease or in any other agreement now existing or hereafter entered into with Us or any Assignee, (3) an event of default occurs under any obligation You may now or hereafter owe to any affiliate of Us or any Assignee, and/or (4) You and/or any guarantors or sureties of Your obligations under any Lease (i) die, (ii) go out of business, (iii) commence dissolution proceedings, (iv) merge or consolidate into another entity, (v) sell all or substantially all of Your or their assets, or there is a change of control with respect to Your or their ownership, (vi) become insolvent, admit Your or their inability to pay Your or their debts, (vii) make an assignment for the benefit of Your or their creditors (or enter into a similar arrangement), (viii) file, or there is filed against You or them, a bankruptcy, reorganization or similar proceeding or a proceeding for the appointment of a receiver, trustee or liquidator, or (ix) suffer an adverse change in Your or their financial condition. If You default under a Lease, We may do any or all of the following: (A) cancel such Lease, (B) require You to promptly return the Equipment pursuant to Section 12, (C) take possession of and/or render the Equipment (including any software) unusable (and for such purposes You hereby authorize Us and Our designees to enter Your premises, with or without prior notice or other process of law), and sell, lease or otherwise dispose of the Equipment on such terms and in such manner as We may in Our sole discretion determine, (D) require You to pay to Us, on demand, liquidated damages in an amount equal to the sum of (i) all Payments and other amounts then due and past due under such Lease, (ii) all remaining Payments for the remainder of the Term of such Lease discounted at a rate of 3% per annum, (iii) the residual value of the Equipment estimated by Us at the inception of such Lease (as shown in Our books and records), discounted at a rate of 3% per annum, (iv) interest on the amounts specified in clauses "i", "ii" and "iii" above from the date of demand to the date paid at the rate of 1.5% per month (or the maximum amount permitted by law if less), and (v) all other amounts that may hereafter become due under such Lease to the extent that We will be obligated to collect and pay such amounts to a third party (such amounts specified in sub-clauses "i" through "v" referred to below as the "Balance Due"), and/or (E) exercise any other remedy available to Us under law. You also agree to reimburse Us on demand for all reasonable expenses of enforcement (including, without limitation, reasonable attorneys' fees and other legal costs) and reasonable expenses of repossessing, holding, preparing for disposition, and disposition ("Remarketing") of the Equipment, plus interest at the rate in sub-clause (iv) on the foregoing amounts from the date of demand to the date paid. In the event We are successful in Remarketing the Equipment, We shall give You a credit against the Balance Due in an amount equal to the present value of the proceeds received and to be received from Remarketing minus the above-mentioned costs (the "Net Proceeds"). If the Net Proceeds are less than the Balance Due, You shall be liable for such deficiency. Any delay or failure to enforce Our rights hereunder shall not constitute a waiver thereof. The remedies set forth herein are cumulative and may be exercised concurrently or separately.

**12. RETURN OF EQUIPMENT.** If You are required to return the Equipment under any Lease, You shall, at Your expense, send the Equipment to any location(s) that We may designate and, if invoiced by Us, pay Us a handling fee of \$250.00. The Equipment must be properly packed for shipment, freight prepaid and fully insured, and must be received in Good Condition (defined in Section 7). All terms of the applicable Lease, including Your obligation to make Payments and pay all other amounts due thereunder shall continue to apply until the Equipment is received by Us in accordance with the terms of this Agreement.

**13. APPLICABLE LAW; VENUE; JURISDICTION; SEVERABILITY.** This Agreement and each Lease shall be deemed fully executed and performed in the state of Iowa and shall be governed and construed in accordance with the laws of the state of Iowa. If Lessor or its Assignee shall bring any judicial proceeding in relation to any matter arising under this Agreement or any Lease, You hereby irrevocably agree that any such matter may be adjudged or determined in any court or courts in the state of Iowa or the state of Lessor's or its Assignee's principal place of business, or in any other court or courts having jurisdiction over You or Your assets, all at the sole election of Lessor or its Assignee. You hereby irrevocably submit generally and unconditionally to the jurisdiction of any such court so elected by Lessor or its Assignee in relation to such matters and irrevocably waive any defense of an inconvenient forum to the maintenance of any such action or proceeding. **YOU AND WE HEREBY WAIVE YOUR AND OUR RESPECTIVE RIGHTS TO A TRIAL BY JURY IN ANY LEGAL ACTION.** If any amount charged or collected under this Agreement or any Lease is greater than the amount allowed by law (an "Excess Amount"), then (i) any Excess Amount charged but not yet paid will be waived by Us and (ii) any Excess Amount collected will be refunded to You or applied to any other amount then due hereunder or thereunder. Each provision of this Agreement and each Lease shall be interpreted to the maximum extent possible to be enforceable under applicable law. If any provision of this Agreement or any Lease is construed to be unenforceable, such provision shall be ineffective only to the extent of such unenforceability without invalidating the remainder hereof or thereof.

**14. DOLLAR PURCHASE.** This Section only applies to Leases under which You have a \$1.00 Purchase Option, as indicated on the related Schedule. With respect to any such Lease, at the end of the Initial Term, You shall purchase the Equipment "AS IS, WHERE IS" for one dollar (\$1.00); provided, however, We shall not be required to transfer Our interest in the Equipment to You until You have paid to Us all amounts then owing under such Lease, if any. You agree that prior to entering into any Lease with a \$1.00 Purchase Option, You could have purchased the Equipment from the Suppliers for a specific cash amount, but instead You hereby choose and agree to pay a higher amount (the "Time Price") to Us in installments over the Initial Term. The Time Price equals the Payment amount shown in the related Schedule multiplied by the total number of Payments to be paid over the Initial Term, plus \$1.00. You agree that the Time Price represents only a higher purchase price and does not include an interest component or finance charge. However, if the Time Price should be determined or adjudicated to include an interest component or finance charge, then you agree that (i) each Payment shall be deemed to include an amount of pre-computed interest, (ii) the total pre-computed interest scheduled to be paid over the Initial Term is to be calculated by subtracting the amount We pay the Suppliers ("Our Investment") from the Time Price, (iii) the annual interest rate deemed applicable to such Lease is the rate that will amortize Our Investment down to \$1.00 by applying all periodic Payments as payments (and this rate calculation method assumes that each periodic Payment is received by Us on the due date), and (iv) none of the other fees or costs We may charge You pursuant to such Lease (including but not limited to UCC filing fees, late fees, documentation or processing fees) shall be considered interest or a finance charge.

**15. MISCELLANEOUS.** You shall furnish Us or an Assignee with current financial statements upon request by Us or an Assignee. You authorize Us or an Assignee to (a) obtain credit reports or make credit inquiries in connection with this Agreement or any Lease, and (b) provide Your credit application, information regarding Your account to credit reporting agencies, potential Assignees, Vendors and parties having an economic interest in this Agreement, a Lease and/or the Equipment. Each Lease may be executed in counterparts, each of which shall be deemed an original, but all of which together shall constitute the same document; provided, however, with respect to a Schedule, only the counterpart which is marked "Original" and is in Our possession shall constitute chattel paper under the UCC. You acknowledge that You have received a copy of this Agreement and each Schedule and agree that a facsimile or other copy containing Your faxed, copied or electronically transmitted signature may be treated as an original and will be admissible as evidence of this Agreement and any Lease. You waive notice of receipt of a copy of this Agreement and any Schedule with Our original signature. You hereby represent to Us that this Agreement is legally binding and enforceable against You in accordance with its terms.



# Schedule to Master Equipment Lease Agreement

Wells Fargo Financial Leasing, Inc. | 800 Walnut, 4th floor | Des Moines, Iowa 50309 | Phone: 866-336-8382

### Customer Information:

Customer's Full Legal Name ("You" and "Your"): City of Killeen

Address: 101 North College Street

City/State/Zip Code: Killeen, TX 76541

County: Bell

Billing Address (if different than Lessee Address shown above)

PO Box 1329, Killeen TX 76540

### Equipment Information:

See Attached Equipment Schedule

Equipment Location (if different than address shown above):

810 Conder, Killeen, TX 76541

Quantity	Equipment Make, Model & Serial Number	Starting Meter	Included Engine Hours Per Year	Excess Charge (per Engine Hour)
(1)	2015 Scag Turf Tiger 61" cut Mower w/clam shell spindle drive grass catcher and installation kit		<600 Hrs/Yr	\$15/Hr
(3)	2015 Scag Turf Tiger 72" cut Mower w/suspension seat		<600 Hrs/Yr	\$15/Hr
(2)	2015 Hustler Super 104 104" cut Mower		<600 Hrs/Yr	\$15/Hr
(1)	2015 Smithco Super Star LE Bunker Rake w/hydraulic kit for mid scarifier, vertical blades, gauge wheels, front plow aluminum blade, flex action finisher/leveler		<600 Hrs/Yr	\$15/Hr
(1)	2015 Smithco Super Star LE Bunker Rake w/hydraulic kit for mid scarifier, vertical blades, gauge wheels, flex action finisher/leveler		<600 Hrs/Yr	\$15/Hr
(1)	2015 EZGO Terrain 1000G Gas Utility Vehicle w/headlights, front brush guard, cargo bed, 2" rear receiver, hour meter		<600 Hrs/Yr	\$15/Hr
(1)	2015 Jacobsen Turfcut Mower w/60" flail mower, hydraulic drive		<600 Hrs/Yr	\$15/Hr

**Term And Payment Information:** Initial Term: 36 months Payment\*: \$2,966.73 (\*plus applicable taxes)

Payment Period is "Monthly" unless otherwise noted here: monthly Security Deposit: \$0.00 Documentation/Processing Fee: \$0.00

Advance Payment: \$2,966.73 applied to:  1st Payment  Last Payment  1st and Last Payments

Purchase Option (shall be Fair Market Value unless another option is checked):  Fair Market Value  \$1.00  Other: \_\_\_\_\_

This is a Schedule that is being entered into subject to the master agreement referenced below (the "Master Agreement") between You and Us. All of the terms and conditions set forth in the Master Agreement are hereby reaffirmed and incorporated in and made part of this Schedule, as if fully set forth herein. The Master Agreement together with this Schedule constitute a Lease (as defined in the Master Agreement) and represent the complete and exclusive agreement between You and Us regarding the leasing of the equipment listed above (together with all existing and future accessories, attachments, replacements and embedded software, the "Equipment"). This Schedule can be changed only by a written agreement between You and Us. Any amendment to the Master Agreement subsequent to the date of this Schedule shall be ineffective as to this Schedule unless otherwise expressly stated in such amendment.

**1. LEASE OF EQUIPMENT.** You hereby agree to lease from Us the Equipment described above upon the terms and conditions set forth in this Schedule and in the Master Agreement.

**2. PURCHASE OPTION.** The above Purchase Option may be exercised by You only at the end of the Initial Term of this Lease. If you are in default under this Lease at the time You desire to exercise the above Purchase Option, You must cure such default(s) to Our satisfaction before having the right to exercise such option.

**3. MISCELLANEOUS.** This Schedule may be executed in counterparts, each of which shall be deemed an original, but all of which together shall constitute the same document; provided, however, only the counterpart which is marked "Original" and is in Our possession shall constitute chattel paper under the UCC. You acknowledge that You have received a copy of the Master Agreement and this Schedule and agree that a facsimile or other copy containing Your faxed, copied or electronically transmitted signature may be treated as an original and will be admissible as evidence of this Lease. You waive notice of receipt of a copy of this Schedule with Our original signature. You hereby represent to Us that this Lease is legally binding and enforceable against You in accordance with its terms. **This Lease is non-cancelable for the full Term.**

Customer: (identified above) <u>City of Killeen</u>	<u>Wells Fargo Financial Leasing, Inc. ("We," "Us" and "Our")</u>
By: _____ Date: ____ / ____ / ____	By: _____ Date: ____ / ____ / ____
Print name: <u>Glenn Morrison</u> Title: <u>City Manager</u>	Print name: _____ Title: _____
	Schedule Number: _____
	Master Agreement Number: _____





# Non-Appropriation Addendum

Wells Fargo Financial Leasing, Inc. | 800 Walnut, 4th floor | Des Moines, Iowa 50309 | Phone: 800-247-5083

Title of lease, rental or other agreement: **Master Equipment Lease Agreement** (the "Agreement")

Lessee/Renter/Customer: **City of Killeen** ("Customer")

This Addendum (this "Addendum") is entered into by and between Customer and Wells Fargo Financial Leasing, Inc. ("Company"). This Addendum shall be effective as of the effective date of the Agreement.

**1. INCORPORATION AND EFFECT.** This Addendum is hereby made a part of, and incorporated into, the Agreement as though fully set forth therein. As modified or supplemented by the terms set forth herein, the provisions of the Agreement shall remain in full force and effect, provided that, in the event of a conflict between any provision of this Addendum and any provision of the Agreement, the provision of this Addendum shall control.

**2. GOVERNMENTAL PROVISIONS.** Customer hereby represents, warrants and covenants to Company that: (a) Customer intends, subject only to the provisions of this Addendum, to remit to Company all sums due and to become due under the Agreement for the full term; (b) Customer's governing body has appropriated sufficient funds to pay all payments and other amounts due during Customer's current fiscal period; (c) Customer reasonably believes that legally available funds in an amount sufficient to make all payments for the full term of the Agreement can be obtained; and (d) Customer intends to do all things lawfully within its power to obtain and maintain funds from which payments due under the Agreement may be made, including making provision for such payments to the extent necessary in each budget or appropriation request submitted and adopted in accordance with applicable law. If Customer's governing body fails to appropriate sufficient funds to pay all payments and other amounts due and to become due under the Agreement in Customer's next fiscal period ("Non-Appropriation"), then (i) Customer shall promptly notify Company of such Non-Appropriation, (ii) the Agreement will terminate as of the last day of the fiscal period for which appropriations were received, and (iii) Customer shall return the Equipment to Company pursuant to the terms of the Agreement. Customer's obligations under the Agreement shall constitute a current expense and shall not in any way be construed to be a debt in contravention of any applicable constitutional or statutory limitations or requirements concerning Customer's creation of indebtedness, nor shall anything contained herein constitute a pledge of Customer's general tax revenues, funds or monies. Customer further represents, warrants and covenants to Company that: (a) Customer has the power and authority under applicable law to enter into the Agreement and this Addendum and the transactions contemplated hereby and thereby and to perform all of its obligations hereunder and thereunder, (b) Customer has duly authorized the execution and delivery of the Agreement and this Addendum by appropriate official action of its governing body and has obtained such other authorizations, consents and/or approvals as are necessary to consummate the Agreement and this Addendum, (c) all legal and other requirements have been met, and procedures have occurred, to render the Agreement and this Addendum enforceable against Customer in accordance with their respective terms, and (d) Customer has complied with all public bidding requirements applicable to the Agreement and this Addendum and the transactions contemplated hereby and thereby.

**3. INDEMNIFICATION.** To the extent Customer is or may be obligated to indemnify, defend or hold Company harmless under the terms of the Agreement, any such indemnification obligation shall arise only to the extent permitted by applicable law and shall be limited solely to sums lawfully appropriated for such purpose in accordance with Section 2 above.

**4. REMEDIES.** To the extent Company's remedies for a Customer default under the Agreement include any right to accelerate amounts to become due under the Agreement, such acceleration shall be limited to amounts to become due during Customer's then current fiscal period.

**5. GOVERNING LAW.** Notwithstanding anything in the Agreement to the contrary, the Agreement and this Addendum shall be governed by, construed and enforced in accordance with the laws of the state in which Customer is located.

**6. MISCELLANEOUS.** This Addendum, together with the provisions of the Agreement not expressly inconsistent herewith, constitutes the entire agreement between the parties with respect to the matters addressed herein, and shall supersede all prior oral or written negotiations, understandings and commitments regarding such matters. This Addendum may be executed in any number of counterparts, each of which shall be deemed to be an original, but all of which together shall be deemed to constitute one and the same agreement. Customer acknowledges having received a copy of this Addendum and agrees that a facsimile or other copy containing Customer's faxed, copied or electronically transmitted signature may be treated as an original and will be admissible as evidence of this Addendum.

Customer (identified above): <b>City of Killeen</b>		<b>Wells Fargo Financial Leasing, Inc.</b>	
By:	Date: ___ / ___ / ___	By:	Date: ___ / ___ / ___
Print name: <b>Glenn Morrison</b>	Title: <b>City Manager</b>	Print name:	Title:
		<b>Agreement Number:</b>	
		<b>Master Agreement Number (if applicable):</b>	



# Delivery & Acceptance Certificate

Wells Fargo Financial Leasing, Inc. | 800 Walnut, 4th floor | Des Moines, Iowa 50309 | Phone: 866-336-8382

**Title of lease, rental or other agreement: Master Equipment Lease Agreement (the "Agreement")**

**Lessee/Renter/Customer: City of Killeen ("Customer")**

The Customer named above hereby unconditionally represents and certifies to Wells Fargo Financial Leasing, Inc. ("Wells Fargo"), and agrees, that:

1. The equipment, other personal property and software, if any, described below (collectively, the "Goods") which have been leased or otherwise provided to Customer or otherwise constitutes collateral under the above-referenced Agreement, has been fully delivered and installed at Customer's place of business, has been inspected and tested by Customer and is operating in good working order to Customer's complete satisfaction, meets all of Customer's requirements and specifications, and is hereby irrevocably accepted by Customer.

**Equipment List:**

**(1) 2015 Scag Turf Tiger 61" cut Mower w/clam shell spindle drive grass catcher and installation kit**

**(3) 2015 Scag Turf Tiger 72" cut Mower w/suspension seat**

**(2) 2015 Hustler Super 104 104" cut Mower**

**(1) 2015 Smithco Super Star LE Bunker Rake w/hydraulic kit for mid scarifier, vertical blades, gauge wheels, front plow aluminum blade, flex action finisher/leveler**

**(1) 2015 Smithco Super Star LE Bunker Rake w/hydraulic kit for mid scarifier, vertical blades, gauge wheels, flex action finisher/leveler**

**(1) 2015 EZGO Terrain 1000G Gas Utility Vehicle w/headlights, front brush guard, cargo bed, 2" rear receiver, hour meter**

**(1) 2015 Jacobsen Turfcut Mower w/60" flail mower, hydraulic drive**

2. There are no side agreements between Customer and any third party relating to the subject matter of the Agreement, and no cancellation rights have been granted to Customer by Wells Fargo or any third party. There is no "free demonstration" or "test" period for the Goods.

3. Customer has reviewed and understands all of the terms of the Agreement, and Customer agrees that the Agreement cannot be revoked or cancelled or terminated early for any reason.

Customer hereby directs Wells Fargo to pay the vendor/supplier of the Goods. Customer agrees that (i) Wells Fargo may insert the Agreement number (and Master Agreement Number, if applicable) and the date below if either is missing following the Customer's signature below, and (ii) a facsimile or other copy of this document containing your faxed, copied or electronically transmitted signature may be treated as an original for all purposes.

**Instruction to Customer: Do NOT sign this Certificate until ALL of the Goods have been delivered, installed, inspected and tested to your satisfaction.**

**Customer (identified above): City of Killeen**

By: \_\_\_\_\_

Date: \_\_\_\_ / \_\_\_\_ / \_\_\_\_

Print name: **Glenn Morrison**

Title: **City Manager**

**Agreement Number:** \_\_\_\_\_

**Master Agreement Number (if applicable):** \_\_\_\_\_



## Customer Insurance Certification

Lessee: City of Killeen Application Number: 860393

**Liability Coverage**  Minimum coverage of \$1 million  
 Wells Fargo Financial Leasing to be listed as additional insured.

Name of Insurance Agency:	Phone Number of Agency:
Mailing Address of Agency:	Fax Number of Agency:
Email Address of Agency:	

**Property Coverage**  Value of equipment covered  
 Wells Fargo Financial Leasing to be listed as the Lenders loss payable endorsement.

<b>PROPERTY</b> - Name of Insurance Agency:	Phone Number of Agency:
Mailing Address of Agency:	Fax Number of Agency:
Email Address of Agency:	

We agree and understand that, under the terms of our Master Lease Agreement with you, we must at all times keep the Equipment under the Schedule referenced above insured against all risks, loss, damage or destruction for the full replacement cost with Wells Fargo Financial Leasing, Inc. named as sole loss payee. Additionally, we must maintain, throughout the term of the Schedule, public liability insurance in the amounts specified in the Master Lease and name Wells Fargo Financial Leasing, Inc. as an additional Insured. We must receive thirty (30) days prior notice before any termination, modification or cancellation for all types of Insurance. I authorize you to contact the agencies identified above and authorize the agents to release insurance certificates to Wells Fargo indicating the above.

\_\_\_\_\_  
Lessee Signature

\_\_\_\_\_  
Date

**Send to Wells Fargo Financial Leasing, Inc. via mail to:** Wells Fargo Financial Leasing, Inc., Golf and Turf Division, MAC# N0005-044, 800 Walnut Street, Des Moines, IA 50309; **or via Fax to:** Wells Fargo Financial Leasing, Inc., attn: Golf and Turf Division Fax #866-336-8375.

<i>Office Use Only</i>		
Contact Date:	Contact Name:	
Insurance Company(s):		
Policy No(s):	Expiration Date(s):	Insured Value:
Named Sole Loss Payee: <b>Wells Fargo Financial Leasing, Inc.</b>		Verified By:
<input type="checkbox"/> YES <input type="checkbox"/> WILL BE ADDED		
Additional Insured: <b>Wells Fargo Financial Leasing, Inc.</b>	Public Liability Insurance Limits:	
<input type="checkbox"/> YES <input type="checkbox"/> WILL BE ADDED		

**AMENDMENT TO SCHEDULE TO MASTER EQUIPMENT LEASE AGREEMENT**

**THIS AMENDMENT TO SCHEDULE TO MASTER EQUIPMENT LEASE AGREEMENT** is by and between **City of Killeen**, as Customer, and **WELLS FARGO FINANCIAL LEASING, INC** as Owner.

**BACKGROUND**

A. By that certain MASTER EQUIPMENT LEASE AGREEMENT, # \_\_\_\_\_ dated \_\_\_\_\_, 20\_\_, by and between Owner and Customer. Owner has agreed to extend financing to Customer upon and subject to the terms and conditions set forth in the MASTER EQUIPMENT LEASE AGREEMENT ("**Agreement**")

B. Owner and Customer desire to amend the terms and conditions of the Agreement, upon and subject to the terms and conditions of this Amendment.

C. All capitalized terms not otherwise defined herein will have the meanings set forth in the Agreement.

**NOW, THEREFORE**, in consideration of good and valuable consideration, the parties intending to be legally bound agree as follows:

1. **Paragraph 3-MISCELLANEOUS.** Sentence 3-This sentence is deleted.

**IN WITNESS WHEREOF**, the duly authorized representatives of the parties have executed this Amendment on the dates set forth below but effective as of the effective date of the Agreement, as set forth above.

**City of Killeen**

By: \_\_\_\_\_

Name: Glenn Morrison

Title: City Manager

Date of Execution: \_\_\_\_\_

**WELLS FARGO FINANCIAL LEASING, INC**

By: \_\_\_\_\_

Name: \_\_\_\_\_

Title: \_\_\_\_\_

Date of Execution: \_\_\_\_\_

**AMENDMENT TO MASTER EQUIPMENT LEASE AGREEMENT**

THIS AMENDMENT TO MASTER EQUIPMENT LEASE AGREEMENT is by and between City of Killeen, as Customer, and WELLS FARGO FINANCIAL LEASING, INC as Owner.

**BACKGROUND**

A. By that certain MASTER EQUIPMENT LEASE AGREEMENT, # \_\_\_\_\_ dated \_\_\_\_\_, 20\_\_, by and between Owner and Customer. Owner has agreed to extend financing to Customer upon and subject to the terms and conditions set forth in the MASTER EQUIPMENT LEASE AGREEMENT ("**Agreement**")

B. Owner and Customer desire to amend the terms and conditions of the Agreement, upon and subject to the terms and conditions of this Amendment.

C. All capitalized terms not otherwise defined herein will have the meanings set forth in the Agreement.

**NOW, THEREFORE**, in consideration of good and valuable consideration, the parties intending to be legally bound agree as follows:

1. **Paragraph 1-LEASE OF EQUIPMENT.** Strike last sentence "You agree that after You sign this Agreement or Schedule..."
2. **Paragraph 7- DELIVERY, LOCATION AND OWNERSHIP OF EQUIPMENT.** The third sentence is amended to "You will not remove the equipment from the equipment location. It is understood that the equipment will be for official city use within the limits of the City of Killeen".
3. **Paragraph 12-RETURN OF EQUIPMENT.** First sentence amended to "If you are required to return the Equipment under and Lease, You shall, at Your expense, send the Equipment to any location(s) within regional proximity that We may designate...."
4. **Paragraph 13- APPLICABLE LAW; VENUE; JURISDICTION; SEVERABILITY.** Sentence 4-"You and We hereby waive your and our respective..." This sentence is deleted.
5. **Paragraph 15-MISCELLANEOUS.** Sentence 5-This sentence is deleted.

**IN WITNESS WHEREOF**, the duly authorized representatives of the parties have executed this Amendment on the dates set forth below but effective as of the effective date of the Agreement, as set forth above.

**City of Killeen**

By: \_\_\_\_\_

Name: Glenn Morrison

Title: City Manager

Date of Execution: \_\_\_\_\_

**WELLS FARGO FINANCIAL LEASING, INC**

By: \_\_\_\_\_

Name: \_\_\_\_\_

Title: \_\_\_\_\_

Date of Execution: \_\_\_\_\_



# City of Killeen

## Legislation Details

---

**File #:** RS-15-020    **Version:** 1    **Name:** Professional Services Contract to Prepare a Parks Master Plan

**Type:** Resolution    **Status:** Resolutions

**File created:** 4/29/2015    **In control:** City Council Workshop

**On agenda:** 5/19/2015    **Final action:**

**Title:** Consider a memorandum/resolution to authorize the award of a professional services contract to Halff & Associates to prepare a Parks Master Plan.

**Sponsors:** Community Services Department, Killeen Parks & Recreation

**Indexes:**

**Code sections:**

**Attachments:** [Council Memorandum Agreement](#)  
[Scope of Services](#)

Date	Ver.	Action By	Action	Result
------	------	-----------	--------	--------

## CITY COUNCIL MEMORANDUM

### AGENDA ITEM

**A professional services contract with Halff & Associates to prepare a Parks Master Plan**

### ORIGINATING DEPARTMENT

**Community Services**

### BACKGROUND INFORMATION

Parks and Recreation drafted and finalized a parks master plan in 2009. The document provides guidance in the overall development of park facilities and related amenities. Killeen's parks master plan has not been updated since 2009. Parks and Recreation has completed twelve of the twenty four projects identified to occur from 2009-2015. In addition, Parks and Recreation has completed an additional six projects not identified in the plan.

Because it is recommended that master plans be updated every 2-3 years, Parks and Recreation issued a Request for Qualifications (RFQ) for another parks master plan, November through December of 2014. Two firms submitted responses: Halff & Associates and Asakura Robinson Company, LLC. The two RFQ's were scored by the Director of Community Services, Assistant Director of Parks and Recreation, and City Planner using a pre-determined scoring methodology. Halff & Associates received the higher overall ranking. Staff then proceeded to negotiate a contract for consideration with Halff & Associates.

### DISCUSSION/CONCLUSION

Parks and Recreation seeks to engage Halff & Associates to draft and finalize a comprehensive parks master plan. Halff & Associates will draft and finalize a document that will be reflective of city council, community, and management input secured through surveys, town hall meetings, and focus groups. This input will then be integrated with a comprehensive review of the strengths and weaknesses of existing facilities and recommended improvements designed to better serve the community. Halff & Associates will also provide a comparison of existing parks and open space standards with actual conditions of Killeen parks and open spaces.

The final document will provide cohesive insight from the aforementioned groups, a detailed audit of existing park facilities, parks needs assessment, a funding plan, and an implementation plan. Halff & Associates will file the final document with the Texas Parks and Wildlife Department for review and comments and will address any comments provided by Texas Parks and Wildlife Department.

A comprehensive parks master plan will assist the City in pursuing grant opportunities, particularly those offered through the Texas Parks and Wildlife Department. Additionally, the parks master plan will better define future funding needs for parks and recreation facilities.

### FISCAL IMPACT

Funds in the amount of \$74,900 are available in account number 348-3490-800.58-89.

## **RECOMMENDATION**

Staff recommends City Council authorize the city manager to enter into a professional services contract with Half & Associates in the amount of \$74,900 to provide parks master plan services.



**STANDARD FORM OF AGREEMENT FOR PROFESSIONAL SERVICES**  
**BETWEEN**  
**CITY OF KILLEEN (CLIENT) AND HALFF ASSOCIATES, INC. (PLANNER)**

**I. SCOPE** - Halff Associates, Inc. (hereinafter "Planner") agrees to perform the professional services described in the attached Scope of Services (Exhibit A) which incorporates these terms and conditions. Unless modified in writing by the parties hereto, the duties of Halff shall not be construed to exceed those services specifically set forth in the Scope of Services. The Scope of Services and these General Terms and Conditions, when executed by the City of Killeen (hereinafter "Client"), shall constitute a binding Agreement on both parties. Planner shall perform its obligations under this agreement as an independent contractor and not as an agent or fiduciary of any other party.

**II. COMPENSATION** - Client agrees to pay monthly invoices or their undisputed portions within 30 days of receipt. Payment later than 30 days shall include interest at 1-1/2 percent per month or lesser maximum enforceable interest rate, from the date the Client received the invoice until the date Planner receives payment. Such interest is due and payable when the overdue payment is made.

It is understood and agreed by the parties that Planner's receipt of payment(s) from Client is not contingent upon Client's receipt of payment, funding, reimbursement or any other remuneration from others.

Time-related charges will be billed as specified in this Agreement. Unless stated otherwise in this Agreement, direct expenses, subcontracted services and direct costs will be billed at actual cost plus a service charge of 10 percent. Mileage will be billed at current IRS rates.

**III. RESPONSIBILITY** - Planner is employed to render a professional service only, and any payments made by Client are compensation solely for the services rendered and the recommendations made in carrying out the work. Planner agrees to follow the standard practices of the Planning profession to make findings, provide opinions, make factual presentations, and provide professional advice and recommendations. Nothing contained herein shall be argued to have created any warranty or certification, and Planner shall not be required to provide any certification, assignment or warranty of its work, but upon request and for a separate fee and at Planner's sole discretion, Planner may agree to provide certain written statements regarding its services. Such statements shall be in a form acceptable to Planner and shall be requested with sufficient advance notice to allow Planner to review the documents and prepare a suitable statement.

Planner's review or supervision of work prepared or performed by other individuals or firms employed by Client shall not relieve those individuals or firms of complete responsibility for the adequacy of their work. It is understood that any resident Planning or inspection provided by Planner is for the purpose of determining compliance with the technical provisions of the project specifications and does not constitute any form of guarantee or insurance with respect to the performance of a contractor. Planner does not assume responsibility for methods or appliances used by a contractor, for safety of construction work, or for compliance by contractors with laws and regulations.

**IV. SCOPE OF CLIENT SERVICES** - Client agrees to provide site access, and to provide those services described in the attached Scope of Services.

**V. OWNERSHIP OF DOCUMENTS** - Upon Planner's completion of services and receipt of payment in full, Planner grants to Client a non-exclusive license to possess the drawings and instruments produced in connection with Planner's performance of the work under this Agreement, if any. Said drawings and instruments may be copied, duplicated, reproduced and used by Client for the purpose of constructing, operating and maintaining the improvements. Client agrees that such documents are not intended or represented to be suitable for reuse by Client or others for purposes outside the Scope of Services of this Agreement. Notwithstanding the foregoing, Client understands and agrees that any and all computer programs, GIS applications, proprietary data or processes, and certain other items related to the services performable under

this Agreement are and shall remain the sole and exclusive property of Planner and may not be used or reused, in any form, by Client without the express written authorization of Planner. With regard to all drawings and instruments, Client agrees that any reuse by Client, or by those who obtain said information from or through Client, without written verification or adaptation by Planner, will be at Client's sole risk and without liability or legal exposure to Planner, Planner's subconsultants or independent associates. Client agrees to indemnify Planner, Planner's subconsultants and independent associates, to the extent allowed by law, for all damages, liability or cost arising from such reuse. Planner may reuse all drawings, reports, data and other information developed in performing the services described by this Agreement in Planner's other activities.

**VI. INDEMNIFICATION** - Planner agrees to indemnify and hold Client harmless from any actual damages, liability or costs, including reasonable attorney's fees and expenses, to the extent caused directly by the negligent act or omission or willful misconduct of Planner, Planner's subconsultants or those for whom Planner is legally liable, in the performance of the professional services which are the subject of this Agreement.

In the event that Client is found to be concurrently negligent, Planner shall not indemnify for the proportionate negligence of Client, but shall only indemnify for the portion of negligence solely attributable to Planner, its agents, servants, employees, subcontractors of any tier and their agents, servants and employees.

Neither party shall be liable to the other for incidental or consequential damages, whether or not the possibility of such damages has been disclosed or could have been reasonably foreseen.

The parties agree to indemnify one another, to the extent allowed by law, against damages of third parties recoverable from the indemnitee to the extent caused by the comparative negligence of the indemnitor. Such negligence shall be measured by standards in effect at the time services are rendered, not by later standards.

Client acknowledges that Planner may perform work at facilities that may contain hazardous materials or conditions, and that Planner had no prior role in the generation, treatment, storage, or disposition of such materials. Planner shall be indemnified and defended by Client, to the extent allowed by law, for any and all claims arising out of the presence of hazardous materials or conditions except for those claims as determined by final judgment of a court of competent jurisdiction to arise out of the sole negligence of Planner.

**VII. INSURANCE** - Planner shall maintain during the life of the Agreement the following minimum insurance:

- A. Commercial general liability insurance, including personal injury liability, blanket contractual liability, and broad form property damage liability. The limit shall be not less than \$1,000,000.
- B. Automobile bodily injury and property damage liability insurance with a limit of not less than \$1,000,000.
- C. Statutory workers' compensation and employers' liability insurance as required by state law.
- D. Professional liability insurance (Errors and Omissions) with a limit of \$1,000,000 per claim/annual aggregate.

**VIII. SUBCONTRACTS** - Planner shall be entitled to subcontract any portion of the work described in the Scope of Services.

**IX. ASSIGNMENT** - This Agreement is binding on the heirs, successors, and assigns of the parties hereto. Neither this Agreement, nor any claims, rights, obligations or duties associated hereto, shall be assigned or assignable by either Client or Planner without the prior written consent of the other party.

**HALFF ASSOCIATES, INC.**

**Standard Form of Agreement - General Terms and Conditions (continued)**

**X. INTEGRATION** - These terms and conditions and the letter agreement (Scope of Services) to which they are attached represent the entire understanding of Client and Planner. No prior oral or written understanding shall be of any force or effect with respect to those matters covered herein. The Agreement may not be modified or altered except in writing signed by both parties.

**XI. JURISDICTION AND VENUE** - This Agreement shall be administered and interpreted under the laws of the State Texas. Exclusive venue shall lie in Bell County, Texas.

**XII. SUSPENSION OF SERVICES** - If work under this Agreement is suspended for more than thirty (30) calendar days in the aggregate, the Planner shall be compensated for services performed and charges incurred prior to receipt of notice to suspend and, upon resumption, an equitable adjustment in fees to accommodate the resulting demobilization and mobilization costs and there also shall be an equitable adjustment in the work schedule based on the delay caused by the suspension. If work under this Agreement is suspended for more than ninety (90) calendar days in the aggregate, the Planner may, at its option, terminate this Agreement upon giving notice in writing to the Client. Planner may request that the work be suspended by notifying Client, in writing, of circumstances that are interfering with normal progress of the work. If the Client fails to make payments when due or otherwise is in breach of this Agreement, the Planner may suspend performance of services upon five (5) calendar days' notice to the Client. The Planner shall have no liability whatsoever to the Client for any costs or damages as a result of such suspension caused by any breach of this Agreement by the Client.

**XIII. TERMINATION OF WORK** - Either the Client or the Planner may terminate this Agreement at any time with or without cause upon giving the other party ten (10) calendar days' prior written notice. Client agrees that termination of Planner for Client's convenience shall only be utilized in good faith, and shall not be utilized if the purpose or result is the performance of all or part of Planner's services under this Agreement by Client or by another service provider. Following such termination and the Client shall, within ten (10) calendar days receipt of a final invoice, pay the Planner for all services rendered and all costs incurred up to the date of Planner's receipt of notice of termination, in accordance with the compensation provisions of this contract.

**XIV. TAXES** - The fees and costs stated in this Agreement, unless stated otherwise, exclude all sales, consumer, use and other taxes. Client agrees to fully reimburse Planner and its subconsultants for taxes paid or assessed in association with the work under this Agreement, whether those taxes were in effect as of the date of this Agreement or were promulgated after the date of this Agreement. This clause shall not apply to taxes associated with reimbursable or other project related expenses, which shall be identified in the applicable invoice for reimbursement by Client.

**XV. ALTERNATIVE DISPUTE RESOLUTION** - Any conflicts or disputes that arise under or through this Agreement or following the completion thereof shall be discussed at a meeting of one senior management person from Client and one from Planner. This meeting shall be a condition precedent to the institution of any legal or equitable proceedings, unless such meeting will infringe upon schedules defined by applicable statutes of limitation or repose. Should such a situation arise, the parties agree that such meeting shall still be required, but the institution of said proceedings shall not be precluded for failure to meet this specific meeting requirement.

**XVI. SEVERABILITY** - Should any one or more of the provisions contained in this Agreement be determined by a court of competent jurisdiction or by legislative pronouncement to be void, invalid, illegal, or unenforceable in any respect, such voiding, invalidity, illegality, or unenforceability shall not affect any other provision hereof, and this Agreement shall be considered as if the

entirety of such void, invalid, illegal, or unenforceable provision had never been contained in this Agreement.

**XVII. TIMELINESS OF PERFORMANCE** - Planner shall perform its professional services with due and reasonable diligence consistent with sound professional practices.

**XVIII. AGREED REMEDIES** - In recognition of the relative risks and benefits of the Project to both the Client and the Planner, and acknowledging that the allocation of risks and limitations of remedies are business understandings between the parties and these risks and remedies shall apply to all possible legal theories of recovery. Client further agrees, to the fullest extent permitted by law, and notwithstanding any other provisions of this Agreement or the existence of applicable insurance coverage, that the total liability, in the aggregate, of the Planner and Planner's officers, directors, employees, agents, and subconsultants to the Client or to anyone claiming by, through or under the Client, for any and all claims, losses, costs or damages whatsoever arising out of, resulting from, or in any way related to, the services under this Agreement from any cause or causes of the Planner or the Planner's officers, directors, employees, agents, and subconsultants, shall not exceed the Planner's fee for the services performed under this Agreement or \$50,000, whichever is greater. Increased limits may be negotiated for additional fee. Further, it is the intent of the parties to this Agreement that Planner's services under this Agreement shall not subject Planner's individual employees, officers or directors to any personal legal exposure for claims and risks associated with the services performed or performable under this Agreement.

**XIX. WAIVER** - Any failure by Planner to require strict compliance with any provision of this Agreement shall not be construed as a waiver of such provision, and Planner may subsequently require strict compliance at any time, notwithstanding any prior failure to do so.

**APPROVED:**  
Planner: HALFF ASSOCIATES, INC.  
Signature: \_\_\_\_\_  
Name: James E. Carrillo  
Title: Vice President  
Date: 5-26-2015

**APPROVED:**  
Client: \_\_\_\_\_  
Signature: \_\_\_\_\_  
Name: \_\_\_\_\_  
Title: \_\_\_\_\_  
Date: \_\_\_\_\_

## EXHIBIT 'A' SCOPE OF SERVICES

### City of Killeen Parks, Recreation and Open Space Master Plan Killeen, Texas

#### 1.00 PROJECT INITIATION

##### CLIENT – CONSULTANT INTERACTION

Interaction between Halff Associates (HA), led by Jim Carrillo, Principal in Charge and Matt Bucchin, Project Manager and Lead Planner, and the City of Killeen Parks and Recreation Department staff (Killeen), will take place either by means of face-to-face meetings or by means of conference call meetings. The number of these meetings is defined per individual task.

##### 1.01 PROJECT INITIATION MEETING & CITY TOUR

Halff Associates (HA) staff will arrange a meeting in Killeen with appropriate City staff as designated by the City. Key Planning Team members from HA participating firms will attend. This meeting will accomplish several pre-planning objectives:

- A. **Orientation.** The City of Killeen and the primary HA team will become familiar with the project team structure and organization and arrive at a complete understanding of the roles and responsibilities of all project participants.
- B. **Review of Key Issues.** Key issues to be addressed during the course of the work will be reviewed with staff and team members.
- C. **Schedule.** Review contract schedule and establish key milestone dates.
- D. **Information exchange.** Discuss documentation needs and receive information as available. HA will provide a list of required information in advance of this meeting.
- E. **Identify planning areas within the city.** Planning areas for use in the survey will be based on available demographic information and previous citywide planning efforts. These areas will be mutually agreed upon by the City and HA.
- F. **City Tour.** HA and Parks Department staff will tour the City in order to become oriented and gain a thorough understanding of issues as identified by City staff.

**Product** - HA shall prepare meeting agenda, initial exhibits to aid discussion, a list of needed informational items and data, and meeting notes.

**Total number of meetings:** One (1) project initiation meeting and a half-day day tour of the city (to be conducted on the same day as the project initiation meeting).

**Items Provided by City of Killeen** – City shall recommend staff to attend, place of meeting, and provide data as required to begin planning process. The City shall arrange for a suitable vehicle and serve as a guide for the duration of the tour. Prior to the tour, the City shall, to the best of its ability and with information readily available, complete the



4030 West Braker Lane, Suite 450  
Austin, Texas 75759  
Phone (512) 777-4600

inventory template as prepared by HA.

## 1.02 INTERDEPARTMENTAL COORDINATION MEETINGS

- A. HA will meet with key personnel of City departments that may impact or be impacted by the Parks Master Plan and from whom support for the implementation of the Parks Master Plan may be required.
- B. HA will conduct one (1) meeting collectively with department heads/staff for their input and issues/concerns/opportunities related to the Parks system and the City as a whole. Personnel/Departments may include, but are not limited to:
- City Management or City Management representatives (see 1.01);
  - Convention & Visitors Bureau;
  - Planning & Development Services;
  - Engineering and/or Public Works; and
  - Police Services.

**Product** – HA shall prepare presentations and summaries of comments made in meetings.

**Total number of meetings:** One (1) meeting

**Items Provided by City of Killeen** – The City shall set up meetings where necessary; and attend the meeting as desired or appropriate. HA shall provide a schedule and suggested time frames for the meeting.

## 1.03 PROJECT MANAGEMENT

The HA Project Manager will coordinate internal and sub-consultant team members; maintain the project schedule; and be available for phone or email discussions to address client needs. HA will provide monthly project update memos (including schedule revisions, status of deliverables, and outstanding needs) via e-mail to the client.

**Product** – Monthly project update memos delivered via e-mail.

**Total number of meetings:** None.

**Items Provided by City of Killeen** – Review of project update memos.

## 2.00 PRE-PLANNING

### 2.01 PREPARATION OF BASE MAPPING

- A. HA shall prepare base mapping that is comprehensive and sufficiently detailed for the project. HA shall prepare the base mapping in a digital form (through incorporation and enhancement of existing City digital base mapping and/or GIS files). GIS data, digital aerial photographs, and/or PDF illustrations obtained from the City will be used as the basis for the regional, citywide and neighborhood level maps which shall include:
- **Regional level** – Including all areas in the City ETJ, as well as relationship to surrounding cities.
  - **City-wide level** – Including study limits/sectors established by prior park master plans and other pertinent sectors as provided by the City of Killeen in digital format.
  - **Specific key areas** – Key neighborhoods/sectors as determined to be appropriate.

- B. All mapping that is distributed in an illustrative format will be in PDF graphic file formats.
- C. Specific information (preferably in GIS shape file format) to be provided by the City of Killeen to be incorporated into the base mapping includes:
- The most recent City mapping, including:
    - i. Regional level maps
    - ii. City-wide maps illustrating existing zoning
    - iii. City maps illustrating existing and proposed land use.
  - Street names
  - Major Utility Corridors
  - Plats (where applicable)
  - City sector identification appropriate for planning purposes (jurisdictional and planning areas) including city limit boundaries and extra-territorial jurisdiction (ETJ) areas (if applicable)
  - Vacant land in the City
  - City owned lands (both park lands and non-parklands)
  - Locations of:
    - i. Parks
    - ii. Recreation Centers
    - iii. Schools
    - iv. Historical Districts
    - v. Utility Easements
    - vi. Creeks/Waterways
    - vii. Drainage ways/easements/Flood plain limits
  - Historic information including
    - i. Historical surveys and update
    - ii. Historical photographs of the City; especially historical photos on civic facilities, homesteads, lake areas, people, culture, parks, open space, recreation activities and trails
  - Schools and Other Parks(by classification and type):
    - i. Names, location and acreage of private and/or HOA parks
    - ii. Location of Schools
    - iii. Future real and potential school sites
  - Developed and undeveloped park land;
  - Information on major employers in Killeen;
  - Key entertainment and civic areas;
  - Major destinations within 1 mile of Killeen in adjacent cities (as readily available);
  - Boundaries for districts such as Killeen Downtown;
  - Key regional destinations as applicable; and
  - Any other pertinent, available GIS data.

**Product** – HA shall prepare base drawings for regional, city-wide, and neighborhood/sector maps with information readily available. HA will coordinate with the City GIS Department

to understand and incorporate data standards and determine the necessary levels of accuracy and precision for data development. Except as stated herein, HA is not responsible for increasing the accuracy and precision or otherwise improving data received from the City.

**Number of meetings:** None.

**Items Provided by City of Killeen** – The City shall provide digital copies (if available), of most recent City mapping, including regional level maps, citywide maps illustrating existing zoning, and city maps illustrating existing and proposed land use. City limit boundaries will be provided in digital form. The City shall also provide data listed in Item C in GIS shape file or geodatabase format and shall help facilitate the coordination of acquiring similar data from adjacent cities or the area regional planning entity.

## 2.02 REVIEW RELEVANT STUDIES THAT MAY INFLUENCE THE PARKS MASTER PLAN

The City of Killeen will provide a digital copy of all plans that may influence the City's Parks Plan. HA shall review these plans. This will include the following typical plan types, but is not limited to:

- Previous Parks Master Plan(s);
- Comprehensive Plan;
- Downtown Plan;
- Trail/Bike Master Plan;
- MPO County-wide Bicycle/Trail Plan;
- Streetscape Plan;
- Thoroughfare Plan;
- Floodplain Management Plan and/or Ordinance;
- Individual Park Development Master Plans;
- Specific master plans previously prepared for key areas;
- Previous Facility Plans/Feasibility Studies;
- Regional plans; and
- Other specific studies.

**Product** – HA shall review past studies and reports, as provided by the City.

**Number of meetings:** None.

**Items Provided by City of Killeen** – City shall provide one electronic copy of all relevant reports and documents.

## 2.03 DEMOGRAPHIC REVIEW & COMMUNITY PROFILE

Data from the City and Central Texas Council of Governments (CTCOG) will be used to develop a community profile that will include the demographic, and economic, characteristics of Killeen. This profile will serve as the basis for future phases of the project.

The community profile shall include:

- Current population;

- Future growth forecasts and build-out projections as provided by the City and CTCOG;
- Typical population profile, including sex, age, ethnicity, income and education; and

**Product** – HA shall review information, as provided by the City, and prepare the community profile.

**Number of meetings:** One (1) conference call meeting with Planning and Development Services and CITY to discuss the best available demographic data to be used.

**Items provided by City of Killeen** – The City shall provide population information (in digital form if available), including existing population by Census tracts, most recent population estimates and projections, and demographic characteristics.

### 3.00 Visioning

A key component of the Visioning process is soliciting and encouraging community involvement, stakeholder input, and developing a vision. Methods employed will include community meetings, stakeholder interviews, and a “visioning workshop.” The process will involve the City, Steering Committee, Key Stakeholder representatives, city staff, the community and other interested parties. The approach recommended by the Consulting Firm is to have a concentrated period dedicated to community involvement and visioning over a 2 to 3 day period. Such a concentrated period of time greatly elevates the level of participation and engagement. The recommended approach and sequence of meetings/interviews/workshops are as follows:

#### 3.01 STEERING COMMITTEE MEETINGS

The Master Plan Steering Committee (the “Committee”) is intended to guide the outcome of this project, provide intermediary reviews of concepts and broad recommendations, and help ensure the plan aligns with the goals of the community. The Committee will be comprised of City staff from key departments, as well as key Council and resident leaders as determined by the City of Killeen. This task includes up to three (3) meetings, as follows:

- **Kick-Off Meeting (1).** Initially, HA will meet with the Committee to introduce the team, describe the master planning process, and conduct a visioning work session.
- **Intermediary Review Meeting (1).** HA will meet with the Committee to present findings, recommendations, cost estimates, and other information. The Committee will be asked to provide input on priorities and goals.
- **Final Review Meeting (1).** HA will present the Final Draft of the Master Plan to the committee and receive comments.

**Product** – HA shall prepare presentation materials for meetings and summarize meeting comments.

**Total number of meetings** – Up to three (3) meetings with electronic communication as needed.



**Items Provided by City of Killeen** – The City shall assemble the Committee, invite Committee members to meetings, and ensure their attendance. City staff is also expected to attend meetings.

### 3.02 VISIONING MEETINGS WITH KEY ENTITIES

HA will meet with key community representatives, present the process of the Master Plan, and facilitate visioning sessions. HA will conduct a maximum of ten (10) focus group meetings and one (1) with the Killeen ISD with a combination of key stakeholder groups or organizations collectively for public input. Meetings will occur consecutively over a two day period, and may include the following groups or individuals.

- Killeen ISD;
- Commission & Board members;
- Economic Development;
- Senior Citizens Groups;
- Arts/Historic/Culture/Beautification Groups;
- Chamber of Commerce;
- Sports Organizations;
- Business Owners and Developers;
- Home Owner Associations;
- Youth/School Groups; and
- Other civic leaders or recreation providers as identified by the City.

**Product** – HA shall prepare a summary of findings and comments made during meetings.

**Total number of meetings:** Ten (10) focus group meetings and one (1) ISD meetings.

**Items Provided by City of Killeen** – The City shall make recommendations for the stakeholders’ representatives and persons to be included in the meetings; set up meetings consecutively during a one to two day period; and attend meetings as desired or appropriate.

### 3.03 ESTABLISH GOALS AND OBJECTIVES

- A. HA shall compile a preliminary list of key parks and recreation long term goals and objectives for the Parks system, to serve as a framework for modification by staff and the citizens of Killeen.
- B. These goals will be based on previous policy statements approved by the Parks and Recreation Board, as well as new goals developed through citizen, staff and elected official input.
- C. HA will review the goals and objective with City staff and modify as appropriate per comments received.

**Product** – HA shall prepare a preliminary written list of goals and objectives for staff review and comment.

**Number of meetings:** none

**Items provided by City of Killeen** – The City shall provide previous goals and objectives, policy statements, etc. The City shall review and comment on revised version of goals and objectives.

### **3.04 PARK AND TRAILS VISIONING CITYWIDE PUBLIC MEETING**

- A. HA will conduct one (1) open public meeting to interview, discuss and present proposed park planning efforts ideas and strategies for the City's Master Plan.
- B. HA will prepare exhibits and presentation for the public meeting.
- C. Prepare written summary of key items discussed during meetings.

**Product** – HA shall prepare presentations, exhibits, and graphic boards for the meeting. HA will also compile and summarize the input from the meeting.

**Total number of meetings:** One (1) meeting.

**Items Provided by City of Killeen** – The City shall establish location and time for meeting; issue invitations and publicize meeting; and attend meeting as desired or appropriate.

### **3.05 COMMUNITY SURVEY**

- A. HA will prepare a questionnaire for an on-line community-wide survey to be administered by web and by mail. Draft questionnaire will be transmitted to City staff for review and comment.
- B. The survey will be linked to the City of Killeen website by City IT staff. Halff will prepare send to the City an email "blast" announcement suitable for being transmitted to residents of the City using available email lists and databases provided and administered by the City. The City shall send the survey via email and/or via utility billings to its citizens.
- C. HA will review the questionnaire with City staff via conference call and modify as appropriate.
- D. HA will obtain City approval of survey prior to administering the survey.
- E. HA will divide city into three to four sections for purposes of the survey, using previously identified plans as a basis for the survey.
- F. HA will analyze responses and prepare a summary of key responses in report format.
- G. The City may choose to provide prizes or other incentives to promote completion of the survey.

**Products** – HA shall prepare documentation for community-wide survey and survey results.

**Number of meetings:** One (1) conference call meetings to discuss the survey questions.

**Items Provided by City of Killeen** – The City shall assist in the development of the survey questionnaire; assist in linking the survey instrument to the City website, and promote the survey to Killeen residents via city newsletters, announcements and email blasts; and insert survey questionnaire or notifications of the survey in envelopes and mail via utility billings. The cost of printing, postage (if necessary), envelopes and packaging for placement in utility billings shall be handled by the City and is not included in this scope of services.

#### 4.00 Parks & Open Space System Plan

##### 4.01 INVENTORY & ASSESSMENT OF EXISTING PARKS & OPEN SPACE FACILITIES

- A. **Map parks and open spaces by type.** HA will provide an inventory form in Excel format for completion by City staff. The inventory data to be provided by City staff will include the number and type of facilities in each City park. From this data, Halff will illustrate the general geographic location of all park and open space facilities in Killeen. Facilities to be shown include:
- Existing parks, recreation facilities, open spaces, and trails;
  - Existing recreation/civic facilities;
  - City owned properties, including undeveloped properties;
  - Private or quasi-private recreation facilities (as identified by City staff); and
  - City owned properties, including undeveloped properties.
- B. **Tabular summary of facilities.** From the base inventory provided by the City of Killeen, HA will prepare tabular inventories of facilities in Killeen. Include a comprehensive table, as well as a table for each park type (i.e. neighborhood parks, community parks, etc.) that summarizes the number of facilities in each park.
- C. **Reconnaissance of parks and open space.** HA will conduct a reconnaissance of key parks in Killeen, as identified by the City. This task will result in photographs and notes regarding characteristics of each park.
- D. **Individual park review.** HA review the ten (10) parks identified in Item C, describe each park in terms of its positive and negative aspects, and make recommendations for improvement. HA shall note major deficiencies or readily apparent safety hazards, including potential ADA compliance issues.

**Product** – HA shall, based on information provided by the City, prepare a map that illustrates the geographic location of facilities in the city. HA shall develop an inventory template in table format to be used for an itemizing inventory of facilities in each park, classified by park type. HA shall prepare a short write-up with photographs of each of the ten (10) parks identified in Item C.

**Number of meetings:** Two (2) conference call meetings to discuss the inventory template and the completed form as provided by the City. One (1) reconnaissance site visit.

**Items provided by City of Killeen** – The City shall provide a copy of current site plans for each existing park in the city (as available). The City shall, to the best of its ability and with information readily available, provide data for each existing park, including address, size, current classification, inventory, general condition of existing facilities in each existing park, and summary of issues related to each site. The City shall complete the inventory template as prepared by HA. The City shall provide a summary of known information on regional park facilities and other major area recreational attractions, including location, size, types of facilities, and annual or event attendance (known or estimated).

##### 4.02 EVALUATE LEVEL OF SERVICE FOR PARKS AND OPEN SPACE

Review previously adopted Killeen Park and Open Space standards and recommend adjustments or new standards as appropriate. Use the following criteria to evaluate the

standards:

- A. Calculate Current Level of Service (CLOS) for park acreage by category and for amenities and facilities on a per-capita basis. Assess spatial distribution of parks. Review Killeen’s previous levels of service and former targets or standards.
- B. Compare standards with those found in up to five (5) similar cities, including geographically and demographically similar cities, as well as other exceptional model cities.
- C. Develop Target Levels of Service (TLOS) for park land, amenities, and facilities for current and future populations. Use NRPA standards or similar area standards as starting points for comparison only.
- D. Prepare comparison of recommended spatial facilities to actual number of facilities, and develop tables that illustrate deficiencies in each category.

**Product** – HA shall draft park facility standards in table and written format.

**Number of meetings:** Two (2) conference call meetings to discuss park acreage and facility standards respectively.

**Items Provided by City of Killeen** – The City shall provide previous park facility standards; and review and comment on proposed Target Levels of Service.

#### 4.03 PARKS & OPEN SPACE NEEDS ASSESSMENT

- A. HA will prepare a written summary of needs, to include areas of significant deficiencies, in terms of land area and specific types of facilities. HA will compare recommended standards to actual conditions to determine deficiencies.
- B. HA will prepare maps/illustrations as appropriate that demonstrate key needs.
- C. An analysis of the existing parks and open space system will be conducted; this analysis will be comprehensive in nature, reviewing all aspects of the parks system and programs, and will have five major components, which will be synthesized to create a collective needs assessment.
  - Needs based on recommended **Standards and Level of Service**
  - Needs based on **Community Input**
  - Needs based on **Vision, Goals & Objectives**
  - Needs based on **Review of Existing System**
  - Needs based on **Natural and Manmade Resources**

**Products** – HA shall prepare a summary of system needs in text, table and plan format. HA shall prepare a map illustrating key needs.

**Number of meetings:** One (1) meeting to discuss findings report.

**Items Provided by City of Killeen** – The City shall review needs assessment and comment as appropriate.

#### 4.04 PARKS & OPEN SPACE RECOMMENDATIONS & STRATEGIES

Based on the current and anticipated growth in the City of Killeen, HA shall consider and provide recommendations to address the specific needs and goals identified during this phase of the Master Plan. Recommendations may be either citywide or targeted to

specific sectors of the City. These recommendations and strategies will generally be categorized as follows:

- Land Acquisition;
- Park & Facility Development;
- Park Improvements;
- Creek Corridors; and
- Policy Recommendations.

**Products** – HA shall prepare a summary of recommendations in text, table and plan format. HA shall prepare a map illustrating land acquisition and park development recommendations.

**Number of meetings:** One (1) conference call meeting to discuss recommendations.

**Items Provided by City of Killeen** – The City shall review recommendations.

#### 4.05 ORDINANCE REVIEW AND RECOMMENDATIONS

HA shall consider and provide recommendations for the acquisition and/or protection of potential park land, open space, trail corridors and drainage to safeguard against destruction and/or loss of land and opportunities for purposes of public use. HA may recommend that the City consider implementing a Park Dedication ordinance to ensure and realize viable recreation and open space opportunities in the City of Killeen.

- A. Review existing city ordinances related to the development of park facilities, open space, trails and landscape treatments, peer cities and recommend modifications or additions.
- B. Develop standards for recommendation based upon anticipated growth and future city needs for the acquisition and development of park land, future park development and anticipated costs, open space preservation and trail development.

**Product** - HA shall provide recommendations to amend or adapt new ordinances, policies and procedures for park land maintenance and acquisition.

**Number of meetings:** One (1) meeting and one (1) conference call to discuss ordinance recommendations.

**Items Provided by City of Killeen** – City shall provide a copy of any ordinances related to parks or park development (if applicable). Review proposed ordinance and comment

### 5.00 Trails Planning

#### 5.01 TRAILS ANALYSIS AND TRAILS RECOMMENDATIONS

HA shall:

- Map existing and proposed trails recommended by City staff;
- Incorporate existing bicycle recommendations from overall MPO Plan;
- Evaluate additional options for future trail corridors and alignments by trail type (all

weather, natural, crushed granite, etc.) and add to GIS database. Divide into appropriate segments as applicable;

- Present publicly as part of parks master plan presentations;
- Develop preliminary order of magnitude cost estimates for trail corridor segments;
- Develop draft prioritization recommendations and illustrate on mapping
- Develop draft trails recommendations chapter for parks master plan. Include trail standards and key implementation recommendations;
- Develop implementation strategies and potential funding sources for trail projects, including potential partnerships, private development, city trail responsibilities and grant candidate trails;
- Review trails recommendations with city staff in conjunction with parks master plan. Edit/adjust per staff comments;
- Provide digital original and 3 large print maps of trails plan map.

**Product:** HA will develop overall trail recommendations, incorporate previous city trail planning ideas, prepare draft and final trails recommendations with recommended routes, standards and proposed prioritization.

**Number of meetings:** Three review meetings (in conjunction with other park plan review meetings).

**Items Provided by City of Killeen:** The City shall review draft and final recommendations.

## 6.00 Implementation Plan

### 6.01 COST ESTIMATES

HA shall:

- Prepare general order of magnitude cost estimates for key components of the Parks, Recreation and Open Space Plan;
- Use previous bids, current contractor costs where available, or other locally based estimates;
- Use an average dollar amount per acre for land acquisition, incorporating land value information as recommended by City staff; and
- Include cost ranges for proposed improvements, and identify key assumptions and items included in each estimate. Include contingencies that are appropriate for concept level estimates;

**Product:** HA will incorporate the results of the cost estimates in the Action Plan.

**Number of meetings:** One review meeting (in conjunction with other review meetings).

**Items Provided by City of Killeen:** The City shall review estimates and comment as appropriate.

### 6.02 IMPLEMENTATION AND ACTION PLAN

- A. HA shall prepare an **Implementation Plan** for the Parks, Recreation and Open Space Master Plan illustrating the components that are recommended. This plan will include five key elements:
1. **Short range improvements** to meet immediate needs.
  2. **Long range improvements** to meet population growth, enhance the parks system, and meet the needs of City administrative staff.
  3. **Prioritization of improvements**, to fund most critical projects first, based on demonstrated need, with less critical components being incorporated as funding allows.
  4. **Funding strategies** to provide predictable funding resources for the proposed improvements.
  5. **Recreation Programming modifications** and improvements to address key recreation needs and deficiencies.
- B. HA shall prepare a plan illustrating all recommended improvements. These will be presented in four major categories:
- Recreational facilities;
  - Existing parks;
  - Future land acquisition needs; and
  - New facility development.
- C. HA shall prepare an **Action Plan Schedule** for the recommended plan components.
- Develop a 5 year incremental funding level analysis to implement the Master Plan. (Action and Expenditure Plan).

- Use a 5-year short-range time frame, and a 10-year long-range time frame.

**Product:** HA shall prepare prioritization of recommended improvements, an Action Plan in table format, and an implementation plan in written format.

**Number of meetings:** One (1) meeting.

**Items Provided by City of Killeen:** The City shall provide current and past citywide and Park and Leisure Services budgets (for past three years); provide records of past grants and other non-city funding sources; and review Implementation and Action Plan.

## 7.00 Report Preparation & Final Plan Adoption

### 7.01 REPORT PREPARATION, REVIEW, AND APPROVAL

A. HA shall combine the information compiled in each of the tasks above into an image-rich Final Report with the goal of creating an engaging and inspiring document. The document will be prepared in InDesign to accommodate graphic formatting. HA will assist in reviewing the report with City staff, other City departments and City Council. Elements in this task will include:

- Preparation of Report and Submittal of electronic (PDF format) draft to City staff for review.
- One (1) work session with City staff.
- Revisions based on comments received, and preparation of a revised draft report in electronic (PDF) format.
- One (1) work session/briefing presentation with City Council.
- Revisions based on comments received, and preparation of a final report in electronic (PDF) format.
- One (1) public hearing for approval of the final master plan by the City Council.

B. Upon City Council approval, HA shall deliver the approved report to Texas Parks and Wildlife Department for review and comment. HA shall address comments from TPWD staff as required.

**Products:** HA shall prepare electronic (PDF format) draft reports. Total number of drafts includes one draft report, one revised draft report, and one final report for approval.

**Number of meetings:** Halff will attend a total of three (3) meetings/presentations during the approval process.

**Items Provided by City of Killeen:** The City shall review draft reports, set up meetings and agenda items for review and approval of master plan, and distribute electronic or hard copies of the report to staff, the Steering Committee, Boards, and City Council, as outlined above.

### 7.02 MASTER PLAN PUBLISHING

HA shall produce a high-quality, full-color digital (PDF format) original of the Preliminary and Final Master Plan Report for use in immediate printing as part of this contract, as well as future printing and digital publication by the City of Killeen. HA shall prepare up



to two (2) black and white copies of the Preliminary Plan and ten (10) color copies of the Final Master Plan.

**Product:** Halff shall provide a digital original of the Master Plan Report (PDF format) on CD and print up to two (2) black and white copies of the Preliminary Plan and ten (10) color copies of the Final Master Plan. Note that draft reviews will be via electronic files rather than printed documents.

**Number of meetings:** None.

**Items Provided by City of Killeen:** The City shall perform a final review of the document and approve final reproduction. Printed originals of the draft and final plans, as necessary, will be provided by the City of Killeen.

**EXHIBIT "B"**  
**Fee Schedule**

**City of Killeen Parks, Recreation and Open Space Master Plan**  
**Killeen, Texas**

**1.00 Basic Services – Fee Summary**

A. Planning services as described will be provided by Halff Associates Inc. on a lump sum basis, with an authorized maximum lump sum contract fee of **\$74,900** for the Parks, Recreation and Open Space Master Plan. The lump sum fee includes a lump sum compensation for base report printing, presentation boards, graphic boards, printing and associated expenses, and mileage expenses necessary for the planning effort.

B. Cost breakdown of services is as follows:

Item #	Item	Meetings	Professional Fee
1.00	<b>Project Initiation</b>	Two (2) staff meetings and (1) meeting with City Manager and/or Mayor; One (1) to two (2) day city tour	\$5,200
2.00	<b>Pre-Planning</b>	One (1) staff conference call	\$8,800
3.00	<b>Parks Visioning (Public Engagement)</b>	Up to three (3) Steering committee meetings; Ten (10) stakeholder meetings; One (1) public meeting; Three (3) staff conference calls	\$19,400
4.00	<b>Parks &amp; Open Space System Plan</b>	Two (2) staff meetings; Six (6) staff conference calls	\$17,200
5.00	<b>Trails Component</b>	One meeting with staff; Up to (3) staff conference calls	\$6,500
6.00	<b>Implementation Plan</b>	One (1) staff conference call	\$2,600
7.00	<b>Report Preparation and Final Plan Adoption</b>	Three (3) meetings during approval process;	\$14,200
<b>Reimbursable Expenses</b>			\$1,000
<b>LUMP SUM TOTAL PARKS MASTER PLAN</b>			<b>\$74,900</b>



**2.00 Additional Services and Meetings**

Should the need arise for additional services, including meetings, Halff can provide such services on an hourly basis and/or agreed upon fee.

Hourly rates are as follows:

Principal:	\$240
Project Manager:	\$160
Park Planner Advisor:	\$115
Planner:	\$ 90
GIS/CAD Operator:	\$ 75
Secretarial/clerk:	\$ 55



# City of Killeen

## Legislation Details

---

**File #:** RS-15-021    **Version:** 1    **Name:** Lease of a dozer for the Solid Waste Transfer Station

**Type:** Resolution    **Status:** Resolutions

**File created:** 3/24/2015    **In control:** City Council Workshop

**On agenda:** 5/19/2015    **Final action:**

**Title:** Consider a memorandum/resolution authorizing the lease of a dozer for the Solid Waste Transfer Station.

**Sponsors:** Solid Waste, Transfer Station, Fleet Services

**Indexes:**

**Code sections:**

**Attachments:** [Council Memorandum](#)  
[WPI Quote](#)  
[Dozer Picture and Standard Equipment List](#)

Date	Ver.	Action By	Action	Result
------	------	-----------	--------	--------

## CITY COUNCIL MEMORANDUM

### AGENDA ITEM

**Authorize lease with purchase option of a dozer for the Solid Waste Transfer Station.**

### ORIGINATING DEPARTMENT

**Fleet Services / Solid Waste**

### BACKGROUND INFORMATION

The Killeen landfill which is comprised of over 200 acres was closed in 1993. Even though it is no longer used, it still requires maintenance to remain in compliance with the Texas Commission on Environmental Quality (TCEQ) rules and regulations to prevent the ponding of water on the closed landfill cells.

Over the years, there have been nearly two million dollars of repairs made to bring the closed landfill into compliance. The past repairs were large scale repairs using a third party vendor. Now that the repairs and maintenance are on a smaller scale, it is more cost effective for CoK personnel to perform the on-going, required repairs. As a result, we are requesting to initiate a three-year dozer lease with a purchase option at the end of the lease.

### DISCUSSION/CONCLUSION

The City of Killeen is a member of several purchasing cooperatives that are in compliance with the Texas Local Government Code section 271.102. After considering three different dozer manufacturers, the dozer recommended by staff utilizing the lease/purchase option is the Komatsu D37EX-23 provided by Waukesha-Pearce Industries (WPI) of North Austin, utilizing the TASB BuyBoard Purchasing Cooperative.

Vendor	Make/Model	Mthly Cost	Purch Option	Total Cost 3-Yr + Purch
WPI	Komatsu D37EX-23	\$2,265.46	\$62,000.00	\$143,556.56

### FISCAL IMPACT

The funds required for this lease were appropriated within the FY 14-15, Solid Waste Hire of Equipment account 540-3475-439.44-10.

### RECOMMENDATION

Staff recommends the procurement of the dozer from WPI, through the TASB BuyBoard, on a three-year lease of \$2,265.46 per month, and the City Manager or designee is authorized to approve the purchase of the equipment at the end of the three-year lease period for \$62,000.00, if the purchase is approved in the FY 17-18 budget, and that the City Manager or designee is expressly authorized to execute any and all change orders within the amounts set by state and local law.



**Waukesha- Pearce Industries, Inc.**  
 16029 I.H. 35 North Austin TX 78761-4684  
 Construction - Mining - Recycling Machinery Solutions  
 www.wpi.com Phone: 1-888-458-0448 Fax: 512-251-0748

**Equipment Quotation**

(This quotation is subject to terms and conditions)

**Quotation To:**  
 CITY OF KILLEEN  
 PO BOX 1329  
 KILLEEN TX 76540  
 Attn: Email:

Quote #: QUO-02863-V6B8L1  
 Date: 3/27/2015  
 Delivery Date: TBD  
 REQ:

We at WPI are pleased to offer you the following equipment for your consideration.

**New KOMATSU D37EX-23 S/N TBD**

- Three shank ripper
- Rear hydraulics

**WARRANTY:** 1 Yr / Unlimited Hrs Complete Machine

**EXTENDED WARRANTY:** 3 yr / 5,000 hr Powertrain Only

**Total Sales Price (Ea)**

**\$133,368.45**

Finance Terms				
<b>Down Payment</b>			<i>Net Sales Price</i>	\$133,368.45
<b>Amount Financed</b>	\$133,818.45		<i>Sales Tax</i>	\$0.00
<b>Fees</b>	\$450.00		<i>Diesel Tax</i>	\$0.00
<b>Months</b>	<b>Rates</b>	<b>Monthly Payment</b>	<i>HET</i>	\$0.00
			<i>Total Sales Price</i>	\$133,368.45

We look forward to your valued order. If you have any questions or comments please feel free to contact me at 512-663-8018 or perrye@wpi.com

Regards,  
 Ed Perry

CUSTOMER HAS READ, UNDERSTANDS AND ACKNOWLEDGES THE TERMS / CONDITIONS AS SET FORTH IN THIS DOCUMENT.  
 This quote becomes a sales order upon written acceptance by BOTH parties subject to those terms and conditions. This order is not valid unless accepted by an authorized WPI Manager.

Accepted: WAUKESHA-PEARCE INDUSTRIES, INC.

Accepted: CITY OF KILLEEN

By: \_\_\_\_\_

X \_\_\_\_\_

Title: \_\_\_\_\_ Date: \_\_\_\_\_

Title: \_\_\_\_\_ Date: \_\_\_\_\_





**Texas Association of School Boards  
BUYBOARD Quotation**



Quote Date	March 26, 2015	Quote Request No.	Verbal
Quotation To		Contract No.	<b>424-13</b>
Buying Agency	CITY OF KILLEEN	Vendor ID	<b>837</b>
Contact	Terry Hardcastle	<b>Waukesha-Pearce Industries Inc.</b>	
Phone	(254) 501-7778	Construction Machinery Division	
Fax		Contact	Ed Perry
Email	n-a	Phone	512-251-0013
		Fax	
		Email	<a href="mailto:perrye@wpi.com">perrye@wpi.com</a>
Pricing Based On Manufacturer's Price List Dated:	01/05/14	Contract Discount	30.5%
		Factor	69.5%

**A. Base Unit:**

Brand	Model No.	Description	List Price	Net Price
KOMATSU	D37EX-23	Crawler Dozer	\$ 167,825.00	\$ 116,638.38
Includes All Standard equipment & attachments as listed in attached brochures and delivery to your facility.				

**B. Factory options and attachments INSTALLED**

Sales Code	Description	List Price	Net Price
4BD81E	Rear Hydraulics	\$ 4,825.00	\$ 3,353.38
RBD01-F	Ripper - 3 Shank - Paralel link	\$ 13,060.00	\$ 9,076.70
			\$ -
			\$ -
Pricing Includes items listed as "Standard" in the attached PLUS:			\$ -
	<b>Standard One Year / Unlimited Hours Warranty</b>		\$ -
	<b>KOMTRAX full machine monitoring w/ Free Internet Access</b>		\$ -
	<b>KOMATSU TOTAL CARE Scheduled Mintenance - 3/2000</b>		\$ -
Sub Total			\$ 12,430.08

**C. Non-Factory options and attachments INSTALLED**

Sales Code	Description	List Price	Net Price
	36 Total Months / 5,000 hour Extended Warranty (Power Train Only)		\$ 2,700.00
			\$ -
			\$ -
			\$ -
			\$ -
			\$ -
			\$ -
Sub Total			\$ 2,700.00

**D. Other applicable charges. Allowances, Trade-Ins, Special Discounts, etc.**

Description	Net Price	
Inbound Freight (Estimated)	\$ 1,600.00	
	\$ -	
	\$ -	
	\$ -	
Sub Total		\$ 1,600.00

**TOTAL PURCHASE PRICE: \$ 133,368.45**

Delivery: Determined at Time of Order

**Pricing valid for sixty (60) days from this date. Orders after that period must be re-quoted.**

Transmit copy of quotation with purchase order issued to WPI to:  
Texas Association of School Boards, BuyBoard, PO Box 400, Austin, TX 78764-0400 email: [buyboard@tasb.org](mailto:buyboard@tasb.org)



**Quote Summary**

Printed: 3/27/2015 09:00 AM

Quote Number: 4926

Pathfinder: CS/EM/AP11/BA

Customer Name: City of Killeen, TX - D37EX-23 with ripper

Salesman: None assigned

Branch: Houston

Statement of Transaction		Financial Details	
Sales Price	133,368.45	Payments/Term	37 / 37
+ Delivery & Install	0.00	Total Finance Charge	10,188.11
+ Sales Tax	0.00	Total Payments	143,556.56
Cash Price	133,368.45	Cust. Interest Rate	3.50%
- Cash Down	0.00	Contract Date	3/31/2015
- Net Trade	0.00	First Payment Date	5/1/2015
+ Insurance	0.00	Interest Start Date	3/31/2015
Unpaid Balance	133,368.45		
+ Title/Lien Fees	0.00		
+ Other Fees	0.00		
Total Fees	0.00		
<b>Amount Financed</b>	<b>133,368.45</b>		

**Schedule of Payments**

<u>Pmts</u>	<u>Start Date</u>	<u>End Date</u>	<u>Payment Amount</u>	<u>Total Finance Charge</u>	<u>Total Paid</u>
1	3/31/2015	3/31/2015	2,265.46	0.00	2,265.46
35	5/1/2015	3/1/2018	2,265.46	10,008.15	79,291.10
1	4/1/2018	4/1/2018	62,000.00	179.96	62,000.00





## Amortization Schedule

Date: 3/27/2015

Prepared For:

Prepared By: WAUKESHA-PEARCE INDUSTRIES, INC.

Fiscal Year End: December

Amount Financed: \$133,368.45

Term: 37

Customer Rate: 3.50%

Quote Number: 4926

Payment#	Date	Principal	Interest	Payment Amt.	Principal Balance
1	3/31/2015	\$2,265.46	\$0.00	\$2,265.46	\$131,102.99
2	5/1/2015	\$1,883.08	\$382.38	\$2,265.46	\$129,219.91
3	6/1/2015	\$1,888.57	\$376.89	\$2,265.46	\$127,331.34
4	7/1/2015	\$1,894.08	\$371.38	\$2,265.46	\$125,437.26
5	8/1/2015	\$1,899.60	\$365.86	\$2,265.46	\$123,537.66
6	9/1/2015	\$1,905.14	\$360.32	\$2,265.46	\$121,632.52
7	10/1/2015	\$1,910.70	\$354.76	\$2,265.46	\$119,721.82
8	11/1/2015	\$1,916.27	\$349.19	\$2,265.46	\$117,805.55
9	12/1/2015	\$1,921.86	\$343.60	\$2,265.46	\$115,883.69
Year-End Totals:		\$17,484.76	\$2,904.38	\$20,389.14	
10	1/1/2016	\$1,927.47	\$337.99	\$2,265.46	\$113,956.22
11	2/1/2016	\$1,933.09	\$332.37	\$2,265.46	\$112,023.13
12	3/1/2016	\$1,938.73	\$326.73	\$2,265.46	\$110,084.40
13	4/1/2016	\$1,944.38	\$321.08	\$2,265.46	\$108,140.02
14	5/1/2016	\$1,950.05	\$315.41	\$2,265.46	\$106,189.97
15	6/1/2016	\$1,955.74	\$309.72	\$2,265.46	\$104,234.23
16	7/1/2016	\$1,961.44	\$304.02	\$2,265.46	\$102,272.79
17	8/1/2016	\$1,967.16	\$298.30	\$2,265.46	\$100,305.63
18	9/1/2016	\$1,972.90	\$292.56	\$2,265.46	\$98,332.73
19	10/1/2016	\$1,978.66	\$286.80	\$2,265.46	\$96,354.07
20	11/1/2016	\$1,984.43	\$281.03	\$2,265.46	\$94,369.64
21	12/1/2016	\$1,990.22	\$275.24	\$2,265.46	\$92,379.42
Year-End Totals:		\$23,504.27	\$3,681.25	\$27,185.52	
22	1/1/2017	\$1,996.02	\$269.44	\$2,265.46	\$90,383.40
23	2/1/2017	\$2,001.84	\$263.62	\$2,265.46	\$88,381.56
24	3/1/2017	\$2,007.68	\$257.78	\$2,265.46	\$86,373.88
25	4/1/2017	\$2,013.54	\$251.92	\$2,265.46	\$84,360.34
26	5/1/2017	\$2,019.41	\$246.05	\$2,265.46	\$82,340.93
27	6/1/2017	\$2,025.30	\$240.16	\$2,265.46	\$80,315.63
28	7/1/2017	\$2,031.21	\$234.25	\$2,265.46	\$78,284.42
29	8/1/2017	\$2,037.13	\$228.33	\$2,265.46	\$76,247.29
30	9/1/2017	\$2,043.07	\$222.39	\$2,265.46	\$74,204.22
31	10/1/2017	\$2,049.03	\$216.43	\$2,265.46	\$72,155.19
32	11/1/2017	\$2,055.01	\$210.45	\$2,265.46	\$70,100.18
33	12/1/2017	\$2,061.00	\$204.46	\$2,265.46	\$68,039.18
Year-End Totals:		\$24,340.24	\$2,845.28	\$27,185.52	
34	1/1/2018	\$2,067.01	\$198.45	\$2,265.46	\$65,972.17
35	2/1/2018	\$2,073.04	\$192.42	\$2,265.46	\$63,899.13
36	3/1/2018	\$2,079.09	\$186.37	\$2,265.46	\$61,820.04
37	4/1/2018	\$61,820.04	\$179.96	\$62,000.00	\$0.00
Year-End Totals:		\$68,039.18	\$757.20	\$68,796.38	
Grand Totals:		\$133,368.45	\$10,188.11	\$143,556.56	

This schedule recaps the activity between payments and is for informational purposes only. Payoff balances must be calculated by Komatsu Financial Representatives.

Page 1 of 1

3/23/2015 1:21:07 PM



# D37EX-23 Crawler Dozer

## Standard Equipment

### Standard Equipment for Base Machine

#### Engine and related items:

Engine, KOMATSU SAA4D95LE-6 3.26 L displacement  
direct injection, Komatsu variable flow turbocharged, aftercooled,  
EPA Tier 4 Interim emission certified, diesel  
Net HP: 89 HP (66 kW) 2200 RPM (ISO9249 / SAE J1349)  
KDOC - After-Treatment Assembly  
Large-capacity cooling system  
Air cleaner, double element type  
Above hood air intake pipe with centrifugal pre-cleaner  
Grid heater - starting aid in cold weather  
Fan, reversible, electronic control, hydraulic drive, manual reverse  
Exhaust pipe with guard  
Automatic deaeration for fuel line  
Poor fuel (contamination) arrangement ( 10 micron pre-filter w/  
water separator and 2 micron dual layer primary)  
Strainer, fuel tank fill  
Swing open radiator mask  
Reservoir tank, radiator with level gauge

#### Electric system:

Alternator, 60 Ampere (24V)  
Back-up alarm  
Engine shutdown secondary switch  
Sealed harness connectors  
Batteries, 2 x 12V, 184Ah  
Starter, 4.5 kW (24V)  
Sealed harness connectors  
Battery disconnect switch

#### Power Train and Steering Controls

Electronically controlled HST dual mode, Customizable Quick shift  
3 speed / Variable -20 speed) settings  
Palm Command Control (PCCS) with electronic control  
Reverse speed presets  
Counter rotation  
Combination brake / decel pedal

#### Undercarriage:

PLUS rotating bushing long life assembly  
Self adjusting idler support with recoil spring  
Track frames, with 1 carrier rollers  
Track on ground - 2240 mm (88 in)  
Track roller guards, ends and guiding  
Track shoe assembly:  
D37EX: 16" (400 mm) single grouser (PLUS)  
Sprockets, segmented

#### Guards and covers:

Crankcase guard and under guard and front pull hook  
Engine hood and side panels with locks  
ROPS and FOPS level 2

Pictures may show optional equipment  
not included in the quotation.

Sprocket inner guard  
Track roller guard end sections

#### Operator environment:

Cab: integrated ROPS & FOPS with front, rear and  
door wipers, 3 front and 2 rear work lights  
Air conditioner: non-freon type, with  
heater, defroster & pressurizer  
Seat: air -suspension type, cloth, fully adjustable, low-  
back , head rest, fabric material, heated,  
3" retractable seat belt  
Monitor: multi-function, 7 inch, high-resolution, color  
E/P Working mode selection;  
EMMS (Equipment Management Monitoring  
System) including system monitoring with self  
diagnostics, a maintenance reminder and fault code  
memory storage. Rear view monitoring system  
PCCS transmission and implement control  
Electronic fuel control dial  
12V Accessory outlets (2)  
Cup holder  
Mirror, Convex  
Horn, electric  
Radio, AM/FM with auxiliary jack  
Seat belt caution alarm  
Foot rests, high mounted  
Provision mount bosses for screen and sweep installation

#### Hydraulics and controls:

Accumulator for EPC  
Electronic Proportional Control (EPC) blade hydraulics  
Electronic float function  
3 grade control mast mount provision bosses on blade  
O-ring face seal hydraulic connections  
Blade cylinder hoses, standard type

#### Special arrangements:

High altitude arrangement (no fuel  
adjustment to 2,300 m (7,545 ft)  
North American ambient temp arrangement,  
-20°C (-4°F) through +50°C (+122°F) at Sea Level  
OSHA Arrangement

#### Vandalism protection:

Filler cap and cover locks

#### Other Standard Equipment:

Marks and plates, for USA and Puerto Rico  
KOMTRAX , level 4  
Paint, Komatsu standard  
Grease gun holder  
Parts book and O&M Manual





# City of Killeen

## Legislation Details

---

**File #:** RS-15-022    **Version:** 1    **Name:** Property Donation  
**Type:** Resolution    **Status:** Resolutions  
**File created:** 5/1/2015    **In control:** City Council Workshop  
**On agenda:** 5/19/2015    **Final action:**  
**Title:** Consider a memorandum/resolution authorizing the donation of obsolete City property to the Bell County Information Technology Department.  
**Sponsors:** Information Technology Department  
**Indexes:**  
**Code sections:**  
**Attachments:** [Council Memorandum](#)  
[Property Donation](#)

Date	Ver.	Action By	Action	Result
------	------	-----------	--------	--------

## **CITY COUNCIL MEMORANDUM**

### **AGENDA ITEM**

### **DONATION OF CITY PROPERTY TO BELL COUNTY INFORMATION TECHNOLOGY DEPARTMENT**

### **ORIGINATING DEPARTMENT**

### **INFORMATION TECHNOLOGY SERVICES DEPARTMENT**

### **BACKGROUND INFORMATION**

The Information Technology Services (ITS) Department has been disposing of end-of-life-cycle equipment through various means over the past few months. The equipment was either sold during an online auction or deemed unserviceable and removed as recyclable material. In all instances, the hard drive and memory of each device was removed and disposed of, under the supervision of the Executive Director. Other items remain that are still usable and of small monetary value; staff recommends that these items be donated to Bell County.

### **DISCUSSION/CONCLUSION**

The ITS Department is seeking approval to donate end-of-life-cycle equipment to Bell County. The equipment in the attached memorandum consists of four (4) Printronix Printers (approximate value of \$495 each) and ten (10) Havis vehicle computer mounts (approximate value \$75 each). Printronix Printers are no longer being used and have been phased out through software system updates that enable the use of plain paper printers. The Havis mounts are for the Panasonic CF-28/29/30 ToughBooks that the city replaced with more technologically advanced computer systems. The Bell County IT Department continues to use this type of printer and will use the donated devices for repair parts that are otherwise difficult to locate. Bell County will use the Havis mounts to outfit county public safety vehicles that still utilize Panasonic series ToughBooks. In accordance with current City of Killeen Code of Ordinances Section 2-87 and 2-88, disposition approval resides with the City Manager. However, pursuant to state constitutional limitations, donations of property can generally be made only when the City Council makes a finding of a public purpose. In this case, the ITS Department is requesting permission to donate the property to Bell County; therefore, the public purpose is satisfied by a governmental agency's continued use of the property.

### **FISCAL IMPACT**

There is no financial impact to the City of Killeen.

### **RECOMMENDATION**

The City Staff requests that City Council find that the donation of items to the Bell County IT Department serves a public purpose and allow the property to be transferred.

## MEMORANDUM

**To:** Glenn Morrison, City Manager  
**From:** Traci Briggs, Deputy City Attorney   
**Date:** March 25, 2015  
**Subject:** IT Request to donate equipment

---

Attached is a request from IT to donate excess/unserviceable equipment. The city ordinance requires that the department head estimate the present market value of property for disposal. Thomas Moore has estimated that each of the four (4) green printers is worth \$495 and each of the ten (10) vehicle computer mounts is worth \$75. City ordinance allows disposal to be public sale, sealed bid, auction, exchange, donation or other as approved by the City Manager. A copy of the ordinance is attached.

Pursuant to state constitutional limitations, donations of property can generally only be made when the city council makes a finding of a public purpose. In this case, IT is requesting to donate the property to Bell County, so the public purpose seems obvious. The question becomes whether the City Manager can approve the donation, but there is no magic number below which it is legal for the City Manager to approve a donation.

I think the two best options are donation with approval of the City Council or to sell the property to Bell County at a reasonable price. I would not recommend your approval of donation unless you feel that the amount is so minimal that you are comfortable approving it.



Bell County also has a requirement for Havis Vehicle Computer Mounts for vehicles that are currently in use by the county. Donating the Havis Vehicle Computer Mounts will provide the county with enough parts along with their current parts to outfit county vehicles with the required computer mounts.



\_\_\_\_\_  
Thomas A. Moore  
Exec Director, Technology Services

Approved / Disapproved

\_\_\_\_\_  
Glenn Morrison  
City Manager  
City of Killeen

Date: \_\_\_\_\_



Sec. 2-87. - Selection and valuation of property; notice to city manager.

When a department head of the city has property to dispose of, the city manager's office, or his designee, shall be notified, by "deletions - fixed asset register" form, of that fact. The information on the form shall fairly describe each item of personal property by make, model, year, size or other appropriate identifier, along with the department head's estimate of the present market value of the property, and the basis of that estimate. The form shall also state the proposed method of disposition (public sale, sealed bids, auction (live or Internet), exchange, donation, or other). If the property is to be exchanged, then the notice shall fully describe the property to be acquired in the exchange.

*(Code 1963, Ch. 1, art. 9, § 1 [Ord. No. 76-44, §1, 7-27-76]; Ord. No. 97-30, § 1, 5-13-97; Ord. No. 07-088, § 1, 9-25-07)*

Sec. 2-88. - Disposition approval.

- (1) If the estimated present market value of the property is between zero and two thousand dollars (\$2,000.00), then the purchasing division may proceed to dispose of the personal property, in accordance with the procedures stated below, no sooner than the third business day after giving notice to the city manager, unless the manager objects to the disposition during that time period.
- (2) If the estimated present market value is more than two thousand (\$2,000.00), then the manager must approve of the disposal of the property, in writing, before the purchasing division may proceed in accordance with the procedures stated below.

*(Code 1963, Ch. 1, art. 9, § 2 [Ord. No. 76-44, §1, 7-27-76]; Ord. No. 97-30, § 1, 5-13-97; Ord. No. 07-088, § 1, 9-25-07)*

Sec. 2-89. - Method of disposal.

The method of disposal shall be by public sale, sealed bid, auction, exchange, donation, or other as approved by the city manager or his designee.

There is no requirement to advertise the disposition of city-owned surplus property prior to disposal other than advertisement mechanisms provided by auctioneer and/or local newspaper for a minimum of two weeks. However, before disposing of abandoned or confiscated property seized by the police department, the notice requirements of article 18.17 of the Texas Code of Criminal Procedures must be complied with.

*(Code 1963, Ch. 1, art. 9, § 4 [Ord. No. 76-44, §1, 7-27-76]; Ord. No. 97-30, § 1, 5-13-97; Ord. No. 07-088, § 1, 9-25-07)*

City of Killeen  
**DELETIONS**  
 FIXED ASSET REGISTER

Item: <b>PRINTRONIX 6400-012-PRI</b>	Date: <b>MAR 5, 2015</b>
Department <b>IT</b>	Account #
Asset #	Asset Class
Complete Description of Asset Deleted <b>LARGE GREENBAR PRINTER</b>	
Serial # <b>0000A3577</b>	Model # <b>PRINTRONIX 6400-012-PRI</b>
Original Date of Purchase	<del>estimated market value</del> <del>Purchase Price</del> \$ <b>495</b>
Date of Deletion	Price Received (If Sold)
Reason for Deletion <b>EQUIPMENT IS BEYOND LIFE CYCLE AND NO LONGER USED BY COK</b>	
Is This Item Now Tagged? <b>NO</b>	If So, Tag #:
Other Comments:	
Approved by Department Head:	Date:
Approved by Finance Department:	Date:

For Purchasing Use Only

Schedule # \_\_\_\_\_

For Quarter Ended \_\_\_\_\_

Date Posted on Program \_\_\_\_\_

City of Killeen  
**DELETIONS**  
 FIXED ASSET REGISTER

Item: <i>PRINTRONIX 6400-012-PRI</i>	Date: <i>MAR 5, 2015</i>
Department <i>IT</i>	Account #
Asset #	Asset Class
Complete Description of Asset Deleted <i>LARGE GREENBAR PRINTER</i>	
Serial # <i>D000A4629</i>	Model # <i>PRINTRONIX 6400-012-ART</i>
Original Date of Purchase	<i>estimated market value</i> Purchase Price \$ <i>\$495</i>
Date of Deletion	Price Received (If Sold)
Reason for Deletion <i>EQUIPMENT IS BEYOND LIFE CYCLE AND NO LONGER USED BY COK</i>	
Is This Item Now Tagged? <i>NO</i>	If So, Tag #:
Other Comments:	
Approved by Department Head:	Date:
Approved by Finance Department:	Date:

For Purchasing Use Only

Schedule # \_\_\_\_\_

For Quarter Ended \_\_\_\_\_

Date Posted on Program \_\_\_\_\_

City of Killeen  
**DELETIONS**  
 FIXED ASSET REGISTER

Item: <b>PRINTRONIX 6400-012-PRI</b>	Date: <b>MAR 5, 2015</b>
Department <b>IT</b>	Account #
Asset #	Asset Class
Complete Description of Asset Deleted <b>LARGE GREENBAR PRINTER</b>	
Serial # <b>0000E2095</b>	Model # <b>PRINTRONIX 6400-012-PRI</b>
Original Date of Purchase	<i>estimated market value</i> Purchase Price \$ <b>\$495</b>
Date of Deletion	Price Received (If Sold)
Reason for Deletion <b>EQUIPMENT IS BEYOND LIFE CYCLE AND NO LONGER USED BY COK</b>	
Is This Item Now Tagged? <b>NO</b>	If So, Tag #:
Other Comments:	
Approved by Department Head:	Date:
Approved by Finance Department:	Date:

For Purchasing Use Only

Schedule # \_\_\_\_\_

For Quarter Ended \_\_\_\_\_

Date Posted on Program \_\_\_\_\_

City of Killeen  
**DELETIONS**  
 FIXED ASSET REGISTER

Item: <b>PRINTRONIX 6400-012-PRI</b>	Date: <b>MAR 5, 2015</b>
Department <b>IT</b>	Account #
Asset #	Asset Class
Complete Description of Asset Deleted <b>LARGE GREENBAR PRINTER</b>	
Serial # <b>0000110154</b>	Model # <b>PRINTRONIX 6400-012-PRI</b>
Original Date of Purchase	<i>estimated market value</i> Purchase Price \$ <b>495</b>
Date of Deletion	Price Received (If Sold)
Reason for Deletion <b>EQUIPMENT IS BEYOND LIFE CYCLE AND NO LONGER USED BY COK</b>	
Is This Item Now Tagged? <b>NO</b>	If So, Tag #:
Other Comments:	
Approved by Department Head:	Date:
Approved by Finance Department:	Date:

For Purchasing Use Only

Schedule # \_\_\_\_\_

For Quarter Ended \_\_\_\_\_

Date Posted on Program \_\_\_\_\_

City of Killeen  
**DELETIONS**  
 FIXED ASSET REGISTER

Item: <i>VEHICLE COMPUTER MOUNTS</i>		Date: <i>MAR 5, 2015</i>	
Department <i>IT</i>		Account #	
Asset #		Asset Class	
Complete Description of Asset Deleted <i>TEN (10) HAVIS VEHICLE COMPUTER MOUNTS</i>			
Serial # <i>N/A</i>		Model #	
Original Date of Purchase		<del>estimated market value</del> Purchase Price \$ <i>\$75 each</i>	
Date of Deletion		Price Received (If Sold)	
Reason for Deletion <i>EQUIPMENT IS NO LONGER REQUIRED AND NO LONGER USED BY COK</i>			
Is This Item Now Tagged? <i>NO</i>		If So, Tag #:	
Other Comments:			
Approved by Department Head:		Date:	
Approved by Finance Department:		Date:	

For Purchasing Use Only

Schedule # \_\_\_\_\_

For Quarter Ended \_\_\_\_\_

Date Posted on Program \_\_\_\_\_



# City of Killeen

## Legislation Details

---

**File #:** RS-15-023    **Version:** 1    **Name:** Quarterly Investment Report - Q2 FY15  
**Type:** Resolution    **Status:** Resolutions  
**File created:** 5/13/2015    **In control:** City Council Workshop  
**On agenda:** 5/19/2015    **Final action:**  
**Title:** Consider a memorandum/resolution approving the investment report for the quarter that ended March 31, 2015.  
**Sponsors:** Finance Department  
**Indexes:**  
**Code sections:**  
**Attachments:** [Council Memorandum](#)  
[Quarterly Report](#)

Date	Ver.	Action By	Action	Result
------	------	-----------	--------	--------

## CITY COUNCIL MEMORANDUM

### AGENDA ITEM

**Quarterly Investment Report,  
March 31, 2015**

### ORIGINATING DEPARTMENT

**Finance**

### BACKGROUND INFORMATION

The City of Killeen's investment policy requires that a quarterly report of investment activity be submitted to the City Council within a reasonable time after the end of each quarter. The quarterly report shall include a detailed description of the investment position of the City, summarize the investment activity in each pooled fund group, state the total rate of return on the investment portfolio, and contain information regarding the market value and book values of each separately invested asset. The report also states the compliance of the investment portfolio of the City as it relates to the investment strategy expressed in the City's policy and the relevant provisions of the Public Funds Investment Act.

### DISCUSSION/CONCLUSION

The attached investment report summarizes all investment activity for the quarter that ended March 31, 2015. The highlights of the report are as follows:

	Oct - Dec 2014	Jan - March 2015	% Change
Interest Income	\$77,476	\$72,831	-6.00%
Investment Balance	\$146,502,653	\$136,770,587	-6.64%
Average Yield	0.23%	0.24%	.01%

### FISCAL IMPACT

Our investment portfolio directly impacts our interest earnings and aligns with current budgeted amounts.

### RECOMMENDATION

Staff recommends that the City Council approve the attached investment report for the quarter that ended March 31, 2015.





# City of Killeen

## QUARTERLY INVESTMENT REPORT

For the Quarter Ended

March 31, 2015

Prepared by

Valley View Consulting, L.L.C.

The investment portfolio of the City of Killeen is in compliance with the Public Funds Investment Act and the Investment Policy and Strategies.

---

Executive Director of Finance

---

Assistant Director of Finance

**Disclaimer:** These reports were compiled using information provided by the City. No procedures were performed to test the accuracy or completeness of this information. The market values included in these reports were obtained by Valley View Consulting, L.L.C. from sources believed to be accurate and represent proprietary valuation. Due to market fluctuations these levels are not necessarily reflective of current liquidation values. Yield calculations are not determined using standard performance formulas, are not representative of total return yields and do not account for investment advisor fees.

## Strategy Summary:

The Federal Open Market Committee (FOMC) maintained the Fed Funds target range between 0.00% and 0.25% (actual Fed Funds traded +/-10 bps). The European Central Bank (ECB) announced and began a Quantitative Easing plan. The Dollar reacted very strongly - dropping from +/--\$1.40 per Euro to +/--\$1.05 per Euro. This strength could have severe US export implications. New payroll growth plummeted to +126,000, but the unemployment rate remained unchanged. The FOMC met and deleted "patient" from their statement text, then added they would not be "impatient" regarding increasing interest rates. Unfortunately they also reduced their overall growth and interest rate expectations for 2015. The stock markets continue to maintain current levels. Financial institution deposit yields generally provide the best interest earnings opportunity. Continuing to ladder provides strategic advantage.

## Quarter End Results by Investment Category:

<u>Asset Type</u>	<u>Ave. Yield</u>	<u>March 31, 2015</u>		<u>December 31, 2014</u>	
		<u>Book Value</u>	<u>Market Value</u>	<u>Book Value</u>	<u>Market Value</u>
Demand Accounts	0.37%	\$ 6,554,641	\$ 6,554,641	\$ 7,441,852	\$ 7,441,852
Pools/MMA	0.14%	99,615,904	99,615,904	107,933,351	107,933,351
Securities/CDs	0.52%	30,600,042	30,600,042	31,127,451	31,127,451
<b>Totals</b>		<b>\$ 136,770,587</b>	<b>\$ 136,770,587</b>	<b>\$ 146,502,653</b>	<b>\$ 146,502,653</b>

<u>Average Yield (1)</u>		<u>Fiscal Year-to-Date Average Yield (2)</u>	
Total Portfolio	0.24%	Total Portfolio	0.24%
Rolling Three Mo. Treas. Yield	0.03%	Rolling Three Mo. Treas. Yield	0.02%
Rolling Six Mo. Treas. Yield	0.08%	Rolling Six Mo. Treas. Yield	0.07%
		Quarterly TexPool Yield	0.04%
		Interest Income	Bank Fees Offset
	Quarterly \$	72,831	\$ 7,487
	Year-to-date \$	150,307	\$ 17,561

(1) Average Yield calculated using quarter end report yields and adjusted book values and does not reflect a total return analysis or account for advisory fees.

(2) Fiscal Year-to-Date Average Yields calculated using quarter end report yields and adjusted book values and does not reflect a total return analysis or account for advisory fees.

**Treasury Yield Curves**

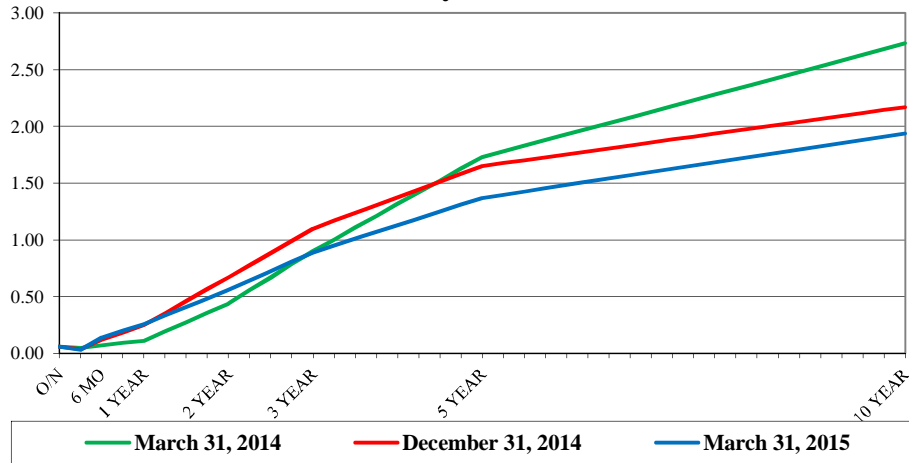

**US Treasury Historical Yields**

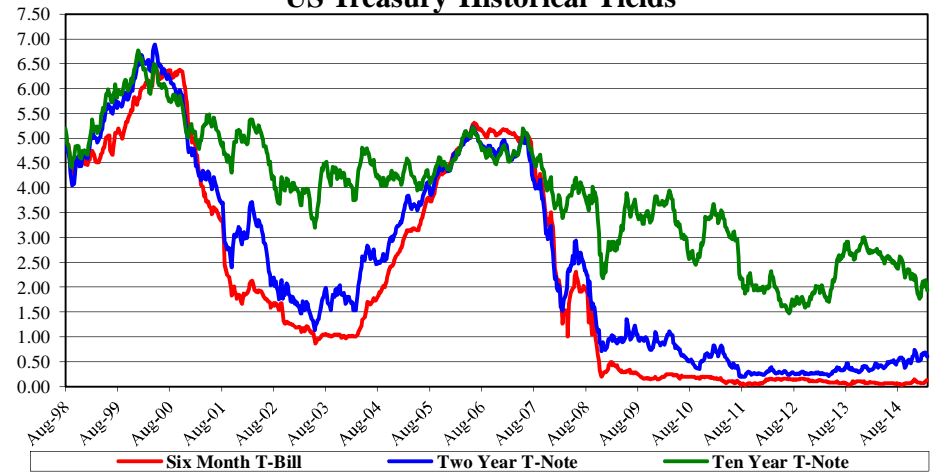

**US Treasury Historical Yields**

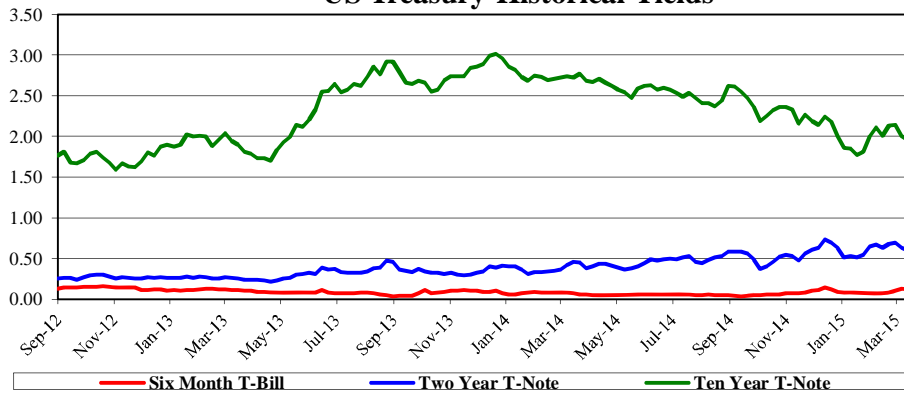

**S&P 500**



## Detail of Holdings

### March 31, 2015

Description	Ratings	Coupon/ Discount	Maturity Date	Settlement Date	Par Value	Book Value	Market Price	Market Value	Life (Days)	Yield
BBVA Demand Account		0.00%	04/01/15	03/31/15	1,577,835	\$ 1,577,835	1.00	\$ 1,577,835	1	0.00%
BBVA DDA Comp. Balance (3)		0.48%	04/01/15	03/31/15	4,965,719	4,965,719	1.00	4,965,719	1	0.48%
Union State Bank		0.15%	04/01/15	03/31/15	11,086	11,086	1.00	11,086	1	0.15%
BBVA Compass MMA 3		0.22%	04/01/15	03/31/15	5,023,063	5,023,063	1.00	5,023,063	1	0.22%
BBVA Compass MMA 4		0.27%	04/01/15	03/31/15	14,575,865	14,575,865	1.00	14,575,865	1	0.27%
FILA (IDP)		0.23%	04/01/15	03/31/15	19,022,308	19,022,308	1.00	19,022,308	1	0.23%
Comerica MMA		0.15%	04/01/15	03/31/15	3,152,708	3,152,708	1.00	3,152,708	1	0.15%
Southside Bank MMA		0.20%	04/01/15	03/31/15	10,077,048	10,077,048	1.00	10,077,048	1	0.20%
TexasTerm	AAAm	0.09%	04/01/15	03/31/15	645,055	645,055	1.00	645,055	1	0.09%
TexPool	AAAm	0.05%	04/01/15	03/31/15	43,474,796	43,474,796	1.00	43,474,796	1	0.05%
TexStar	AAAm	0.06%	04/01/15	03/31/15	3,645,061	3,645,061	1.00	3,645,061	1	0.06%
Central National Bank CD		0.31%	04/26/15	04/26/13	2,011,901	2,011,901	100.00	2,011,901	26	0.31%
Comerica Bank CD		0.53%	04/27/15	04/26/14	2,525,498	2,525,498	100.00	2,525,498	27	0.53%
Central National Bank CD		0.61%	09/05/15	09/05/14	2,006,054	2,006,054	100.00	2,006,054	158	0.61%
Independent Bank CD		0.38%	09/09/15	09/09/14	3,005,656	3,005,656	100.00	3,005,656	162	0.38%
Independent Bank CD		0.38%	09/09/15	09/09/14	3,005,656	3,005,656	100.00	3,005,656	162	0.38%
Independent Bank CD		0.37%	09/17/15	06/17/14	3,016,139	3,016,139	100.00	3,016,139	170	0.37%
Independent Bank CD		0.55%	12/12/15	09/12/14	3,008,188	3,008,188	100.00	3,008,188	256	0.55%
Independent Bank CD		0.35%	03/04/16	03/04/15	1,500,000	1,500,000	100.00	1,500,000	339	0.35%
Central National Bank CD		0.74%	03/05/16	09/05/14	2,007,346	2,007,346	100.00	2,007,346	340	0.74%
Southside Bank CD		0.60%	03/08/16	09/08/14	1,002,978	1,002,978	100.00	1,002,978	343	0.60%
Independent Bank CD		0.55%	06/04/16	03/04/15	2,500,000	2,500,000	100.00	2,500,000	431	0.55%
Southside Bank CD		0.70%	09/08/16	09/08/14	1,003,474	1,003,474	100.00	1,003,474	527	0.70%
Comerica Bank CD		0.72%	09/08/16	09/08/14	2,007,151	2,007,151	100.00	2,007,151	527	0.72%
Comerica Bank CD		0.80%	03/02/17	03/02/15	2,000,000	2,000,000	100.00	2,000,000	702	0.80%
						<b>\$ 136,770,587</b>	<b>\$ 136,770,587</b>		<b>61</b>	<b>0.24%</b>
									<b>(1)</b>	<b>(2)</b>

(1) **Weighted average life** - For purposes of calculating weighted average life, cash equivalent investments are assumed to have a one day maturity.

(2) **Weighted average yield to maturity** - The weighted average yield to maturity is based on adjusted book value, realized and unrealized gains/losses and investment advisory fees are not considered. The yield for the reporting month is used for cash equivalent investments.

(3) **Equivalent Yield of Bank Fees Offset** - Compensating balance in bank operating account yielded an equivalent investment yield as a result of Bank fees offset.

# Portfolio Composition

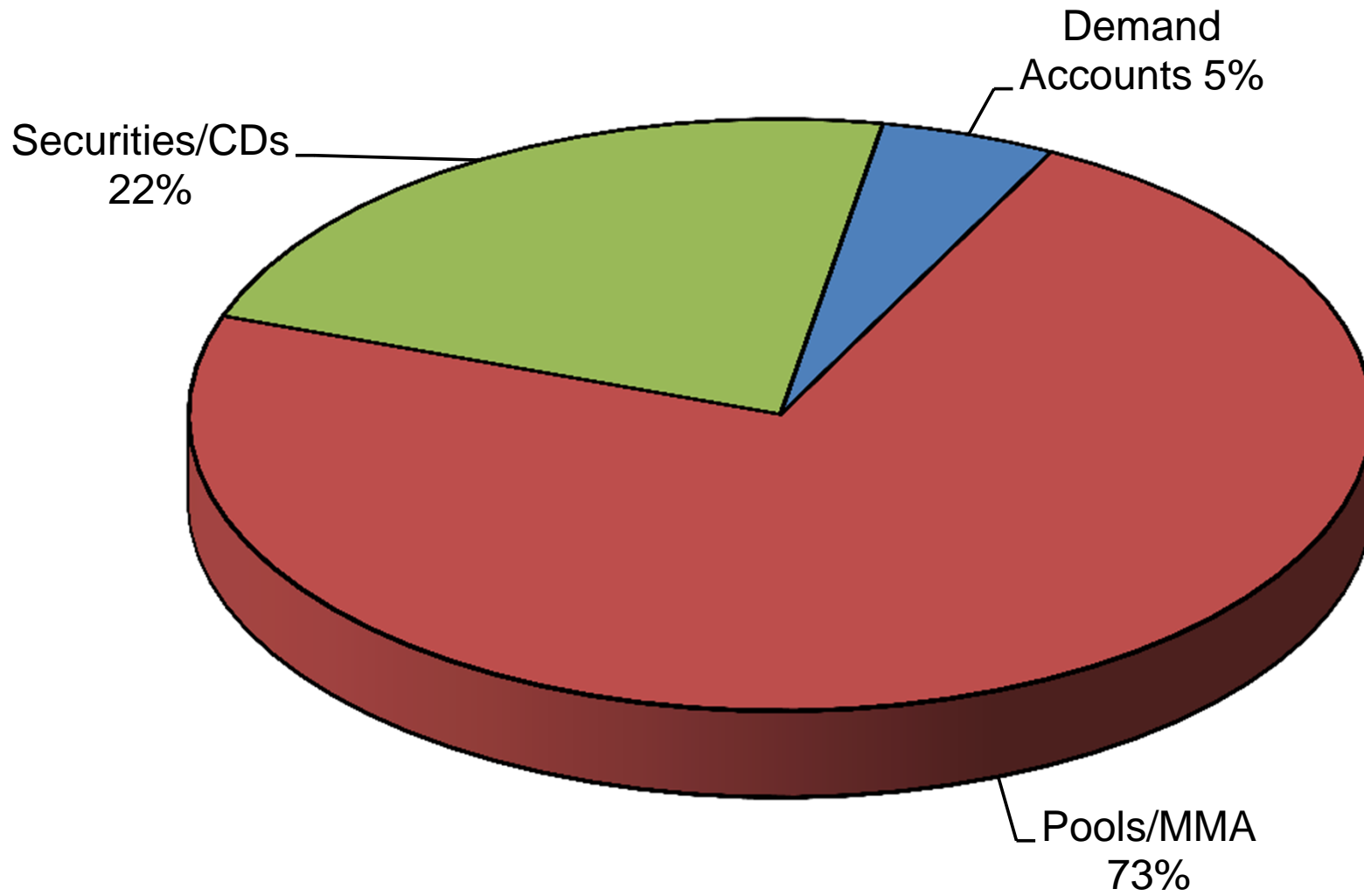

# Total Portfolio

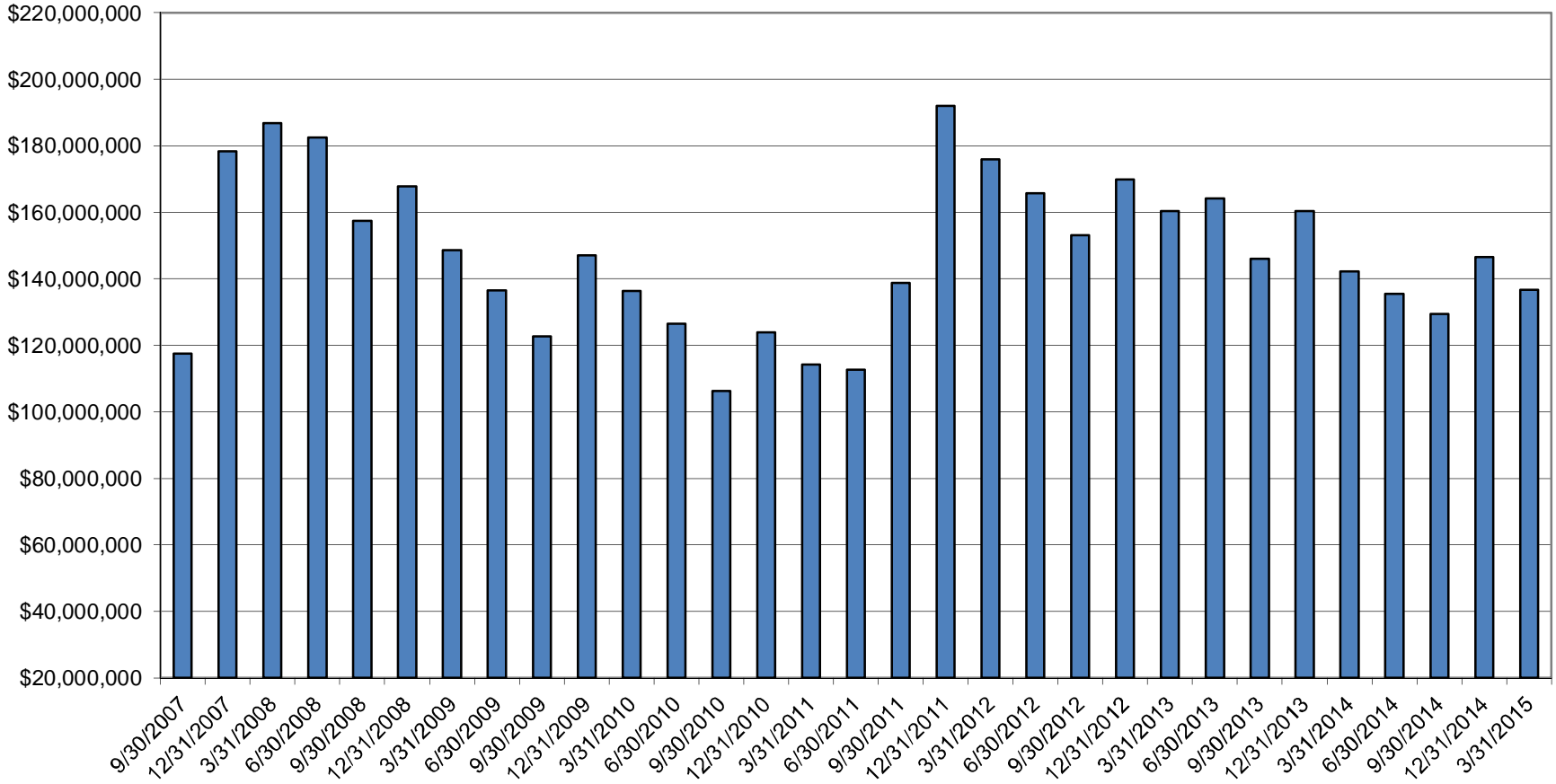

## Book Value Comparison

Description	Coupon/ Discount	Maturity Date	December 31, 2014			March 31, 2015		
			Par Value	Book Value	Purchases/ Adjustments	Sales/Adjust/ Maturities	Par Value	Book Value
BBVA Demand Account		04/01/15	\$ 7,224,126	\$ 7,224,126	\$ -	\$ (680,571)	\$ 6,543,555	\$ 6,543,555
1st Tennessee Bank		04/01/15	206,643	206,643		(206,643)		
Union State Bank	0.15%	04/01/15	11,082	11,082	4		11,086	11,086
BBVA Compass MMA 3	0.22%	04/01/15	5,020,368	5,020,368	2,695		5,023,063	5,023,063
BBVA Compass MMA 4	0.27%	04/01/15	14,566,249	14,566,249	9,616		14,575,865	14,575,865
FILA (IDP)	0.23%	04/01/15	19,011,524	19,011,524	10,784		19,022,308	19,022,308
Comerica MMA	0.15%	04/01/15	3,151,543	3,151,543	1,166		3,152,708	3,152,708
Southside Bank MMA	0.20%	04/01/15	10,072,165	10,072,165	4,883		10,077,048	10,077,048
TexasTerm	0.09%	04/01/15	644,929	644,929	126		645,055	645,055
TexPool	0.05%	04/01/15	51,822,020	51,822,020		(8,347,224)	43,474,796	43,474,796
TexStar	0.06%	04/01/15	3,644,553	3,644,553	508		3,645,061	3,645,061
Comerica Bank CD	0.43%	01/26/15	2,517,998	2,517,998		(2,517,998)		
Comerica Bank CD	0.57%	03/02/15	2,020,084	2,020,084		(2,020,084)		
Comerica Bank CD	0.57%	03/02/15	2,020,084	2,020,084		(2,020,084)		
Central National Bank CD	0.31%	04/26/15	2,010,331	2,010,331	1,571		2,011,901	2,011,901
Comerica Bank CD	0.53%	04/27/15	2,522,201	2,522,201	3,298		2,525,498	2,525,498
Central National Bank CD	0.61%	09/05/15	2,003,042	2,003,042	3,013		2,006,054	2,006,054
Independent Bank CD	0.38%	09/09/15	3,002,842	3,002,842	2,814		3,005,656	3,005,656
Independent Bank CD	0.38%	09/09/15	3,002,842	3,002,842	2,814		3,005,656	3,005,656
Independent Bank CD	0.37%	09/17/15	3,013,390	3,013,390	2,749		3,016,139	3,016,139
Independent Bank CD	0.55%	12/12/15	3,004,114	3,004,114	4,074		3,008,188	3,008,188
Independent Bank CD	0.35%	03/04/16			1,500,000		1,500,000	1,500,000
Central National Bank CD	0.74%	03/05/16	2,003,690	2,003,690	3,656		2,007,346	2,007,346
Southside Bank CD	0.60%	03/08/16	1,001,496	1,001,496	1,482		1,002,978	1,002,978
Independent Bank CD	0.55%	06/04/16			2,500,000		2,500,000	2,500,000
Southside Bank CD	0.70%	09/08/16	1,001,745	1,001,745	1,729		1,003,474	1,003,474
Comerica Bank CD	0.72%	09/08/16	2,003,592	2,003,592	3,559		2,007,151	2,007,151
Comerica Bank CD	0.80%	03/02/17			2,000,000		2,000,000	2,000,000
<b>TOTAL</b>			<b>\$ 146,502,653</b>	<b>\$ 146,502,653</b>	<b>\$ 6,060,539</b>	<b>\$ (15,792,605)</b>	<b>\$ 136,770,587</b>	<b>\$ 136,770,587</b>

## Market Value Comparison

Description	Coupon/ Discount	Maturity Date	December 31, 2014		Qtr to Qtr Change	March 31, 2015	
			Par Value	Market Value		Par Value	Market Value
BBVA Demand Account		04/01/15	\$ 7,224,126	\$ 7,224,126	\$ (680,571)	\$ 6,543,555	\$ 6,543,555
1st Tennessee Bank		04/01/15	206,643	206,643	(206,643)		
Union State Bank	0.15%	04/01/15	11,082	11,082	4	11,086	11,086
BBVA Compass MMA 3	0.22%	04/01/15	5,020,368	5,020,368	2,695	5,023,063	5,023,063
BBVA Compass MMA 4	0.27%	04/01/15	14,566,249	14,566,249	9,616	14,575,865	14,575,865
FILA (IDP)	0.23%	04/01/15	19,011,524	19,011,524	10,784	19,022,308	19,022,308
Comerica MMA	0.15%	04/01/15	3,151,543	3,151,543	1,166	3,152,708	3,152,708
Southside Bank MMA	0.20%	04/01/15	10,072,165	10,072,165	4,883	10,077,048	10,077,048
TexasTerm	0.09%	04/01/15	644,929	644,929	126	645,055	645,055
TexPool	0.05%	04/01/15	51,822,020	51,822,020	(8,347,224)	43,474,796	43,474,796
TexStar	0.06%	04/01/15	3,644,553	3,644,553	508	3,645,061	3,645,061
Comerica Bank CD	0.43%	01/26/15	2,517,998	2,517,998	(2,517,998)		
Comerica Bank CD	0.57%	03/02/15	2,020,084	2,020,084	(2,020,084)		
Comerica Bank CD	0.57%	03/02/15	2,020,084	2,020,084	(2,020,084)		
Central National Bank CD	0.31%	04/26/15	2,010,331	2,010,331	1,571	2,011,901	2,011,901
Comerica Bank CD	0.53%	04/27/15	2,522,201	2,522,201	3,298	2,525,498	2,525,498
Central National Bank CD	0.61%	09/05/15	2,003,042	2,003,042	3,013	2,006,054	2,006,054
Independent Bank CD	0.38%	09/09/15	3,002,842	3,002,842	2,814	3,005,656	3,005,656
Independent Bank CD	0.38%	09/09/15	3,002,842	3,002,842	2,814	3,005,656	3,005,656
Independent Bank CD	0.37%	09/17/15	3,013,390	3,013,390	2,749	3,016,139	3,016,139
Independent Bank CD	0.55%	12/12/15	3,004,114	3,004,114	4,074	3,008,188	3,008,188
Independent Bank CD	0.35%	03/04/16			1,500,000	1,500,000	1,500,000
Central National Bank CD	0.74%	03/05/16	2,003,690	2,003,690	3,656	2,007,346	2,007,346
Southside Bank CD	0.60%	03/08/16	1,001,496	1,001,496	1,482	1,002,978	1,002,978
Independent Bank CD	0.55%	06/04/16			2,500,000	2,500,000	2,500,000
Southside Bank CD	0.70%	09/08/16	1,001,745	1,001,745	1,729	1,003,474	1,003,474
Comerica Bank CD	0.72%	09/08/16	2,003,592	2,003,592	3,559	2,007,151	2,007,151
Comerica Bank CD	0.80%	03/02/17			2,000,000	2,000,000	2,000,000
<b>TOTAL</b>			<b>\$ 146,502,653</b>	<b>\$ 146,502,653</b>	<b>\$ (9,732,066)</b>	<b>\$ 136,770,587</b>	<b>\$ 136,770,587</b>



**Allocation**

**March 31, 2015**

<b>Book &amp; Market Value</b>	<b>Maturity Date</b>	<b>Total</b>	<b>General Operating</b>	<b>Special Revenue</b>	<b>Interest &amp; Sinking</b>	<b>Enterprise Funds</b>	<b>Capital Projects</b>	<b>KEDC</b>
BBVA Demand Account	04/01/15	\$ 6,543,555	\$ 1,688,843	\$ 2,592,748	\$ 829,083	\$ (219,323)	\$ 1,418,453	\$ 233,751
Union State Bank	04/01/15	11,086					11,086	
BBVA Compass MMA 3	04/01/15	5,023,063	2,009,164			1,507,035	1,506,864	
BBVA Compass MMA 4	04/01/15	14,575,865	13,568,601				1,007,264	
FILA (IDP)	04/01/15	19,022,308	2,001,689			9,011,149	8,009,469	
Comerica MMA	04/01/15	3,152,708	3,019,396				133,313	
Southside Bank MMA	04/01/15	10,077,048					10,077,048	
TexasTerm	04/01/15	645,055	52,391			52,348	540,315	
TexPool	04/01/15	43,474,796	2,488,530	1,007,678	13,451,276	6,035,245	15,910,162	4,581,904
TexStar	04/01/15	3,645,061	2,430,041			1,215,020		
Central National Bank CD	04/26/15	2,011,901					2,011,901	
Comerica Bank CD	04/27/15	2,525,498					2,525,498	
Central National Bank CD	09/05/15	2,006,054					2,006,054	
Independent Bank CD	09/09/15	3,005,656					3,005,656	
Independent Bank CD	09/09/15	3,005,656					3,005,656	
Independent Bank CD	09/17/15	3,016,139					3,016,139	
Independent Bank CD	12/12/15	3,008,188					3,008,188	
Independent Bank CD	03/04/16	1,500,000				1,500,000		
Central National Bank CD	03/05/16	2,007,346					2,007,346	
Southside Bank CD	03/08/16	1,002,978				1,002,978		
Independent Bank CD	06/04/16	2,500,000					2,500,000	
Southside Bank CD	09/08/16	1,003,474				1,003,474		
Comerica Bank CD	09/08/16	2,007,151				2,007,151		
Comerica Bank CD	03/02/17	2,000,000	2,000,000					
<b>Totals</b>		<b>\$ 136,770,587</b>	<b>\$ 29,258,655</b>	<b>\$ 3,600,426</b>	<b>\$ 14,280,360</b>	<b>\$ 23,115,079</b>	<b>\$ 61,700,413</b>	<b>\$ 4,815,655</b>

## Allocation

December 31, 2014

Book & Market Value	Maturity Date	Total	General Operating	Special Revenue	Interest & Sinking	Enterprise Funds	Capital Projects	KEDC
BBVA Demand Account	01/01/15	\$ 7,224,126	\$ 3,213,598	\$ 2,273,686	\$ 2,379,548	\$ 77,670	\$ (954,126)	\$ 233,751
1st Tennessee Bank	01/01/15	206,643	206,643					
Union State Bank	01/01/15	11,082					11,082	
BBVA Compass MMA 3	01/01/15	5,020,368	2,008,086			3,012,282		
BBVA Compass MMA 4	01/01/15	14,566,249	5,011,638				9,554,611	
FILA (IDP)	01/01/15	19,011,524	2,000,555			5,004,428	12,006,542	
Comerica MMA	01/01/15	3,151,543	3,018,279				133,263	
Southside Bank MMA	01/01/15	10,072,165	4,028,675				6,043,490	
TexasTerm	01/01/15	644,929	52,381			52,338	540,210	
TexPool	01/01/15	51,822,020	8,532,499	933,568	14,571,469	9,249,613	14,186,229	4,348,643
TexStar	01/01/15	3,644,553	2,429,702			1,214,851		
Central National Bank CD	10/26/14							
Comerica Bank CD	12/01/14							
Comerica Bank CD	01/26/15	2,517,998					2,517,998	
Comerica Bank CD	03/02/15	2,020,084				2,020,084		
Comerica Bank CD	03/02/15	2,020,084	2,020,084					
Central National Bank CD	04/26/15	2,010,331					2,010,331	
Comerica Bank CD	04/27/15	2,522,201					2,522,201	
Central National Bank CD	09/05/15	2,003,042					2,003,042	
Independent Bank CD	09/09/15	3,002,842					3,002,842	
Independent Bank CD	09/09/15	3,002,842					3,002,842	
Independent Bank CD	09/17/15	3,013,390					3,013,390	
Independent Bank CD	12/12/15	3,004,114				3,004,114		
Central National Bank CD	03/05/16	2,003,690					2,003,690	
Southside Bank CD	03/08/16	1,001,496				1,001,496		
Southside Bank CD	09/08/16	1,001,745				1,001,745		
Comerica Bank CD	09/08/16	2,003,592				2,003,592		
<b>Totals</b>		<b>\$ 146,502,653</b>	<b>\$ 32,522,139</b>	<b>\$ 3,207,254</b>	<b>\$ 16,951,017</b>	<b>\$ 27,642,213</b>	<b>\$ 61,597,636</b>	<b>\$ 4,582,394</b>



# City of Killeen

## Legislation Details

---

**File #:** OR-15-009    **Version:** 1    **Name:** Ordinance approving Atmos Settlement Agreement  
**Type:** Ordinance    **Status:** Ordinances  
**File created:** 5/8/2015    **In control:** City Council Workshop  
**On agenda:** 5/19/2015    **Final action:**  
**Title:** Consider an ordinance approving a negotiated settlement between the Atmos Cities Steering Committee and Atmos Energy, Corp., Mid-Tex Division, regarding the 2014 and 2015 Rate Review Mechanism Filings.  
**Sponsors:** City Attorney Department  
**Indexes:**  
**Code sections:**  
**Attachments:** [Council Memorandum](#)  
[Ordinance](#)  
[Attachments to Ordinance](#)

Date	Ver.	Action By	Action	Result
------	------	-----------	--------	--------

## **CITY COUNCIL MEMORANDUM**

### **AGENDA ITEM**

**AN ORDINANCE APPROVING A NEGOTIATED SETTLEMENT BETWEEN THE ATMOS CITIES STEERING COMMITTEE AND ATMOS ENERGY, CORP., MID-TEX DIVISION, REGARDING THE 2014 AND 2015 RATE REVIEW MECHANISM FILINGS**

**ORIGINATING DEPARTMENT**      **City Attorney's Office**

### **BACKGROUND INFORMATION**

By law, cities have original jurisdiction of natural gas rates. The City, along with other cities served by Atmos Energy Mid-Tex Division ("Atmos"), is a member of the Atmos Cities Steering Committee ("ACSC"). State law allows for gas providers to request rate adjustments annually through a process called the Gas Reliability Infrastructure Program ("GRIP"). Finding the GRIP process burdensome and restrictive, Atmos and ACSC agreed in 2007 to an alternate review called the Rate Review Mechanism ("RRM").

### **DISCUSSION/CONCLUSION**

On February 28, 2014, Atmos filed an RRM with the ACSC cities requesting an increase of \$45.7 million. When ACSC and Atmos were unable to negotiate a compromise, ACSC cities denied the requested rate increase. Atmos then appealed to the Railroad Commission ("Commission") and revised its requested increase to \$43.8 million. On April 28, 2015, the Commission issued a Proposal for Decision that was not favorable to ACSC and recommended an \$860,000 reduction of Atmos' request.

On February 27, 2015, Atmos filed another RRM with the Atmos cities requesting an increase of approximately \$28 million.

After ACSC experts analyzed the Proposal for Decision and the 2015 filing, ASCS attorneys began negotiating a settlement that would resolve both the 2014 and 2015 RRM filings. The settlement agreement attached to the proposed ordinance approves a rate increase of \$65.7 million effective on bills on or after June 1, 2015, a reduction of approximately \$6 million for the two combined requests. Atmos also agrees to withdraw its appeal before the Commission, which is important because the Proposal for Decision would otherwise become final and its negative implications would set precedent for future rate proceedings.

### **FISCAL IMPACT**

There is no fiscal impact to the City. The average monthly bill impact for a residential customer will be an increase of \$1.14 per month, an increase of 1.59%. The average commercial customer will see an increase of \$2.69, or 0.96%.

## **RECOMMENDATION**

The ACSC Executive Committee, of which the City is a member based on population, recommends adopting the ordinance approving the negotiated settlement agreement resolving the 2014 and 2015 RRM filings, and implementing the rate changes.

ORDINANCE NO. \_\_\_\_\_

**AN ORDINANCE OF THE CITY COUNCIL OF THE CITY OF KILLEEN, TEXAS, APPROVING A NEGOTIATED SETTLEMENT BETWEEN THE ATMOS CITIES STEERING COMMITTEE (“ACSC”) AND ATMOS ENERGY CORP., MID-TEX DIVISION REGARDING THE COMPANY’S 2014 AND 2015 RATE REVIEW MECHANISM FILINGS; APPROVING A SETTLEMENT AGREEMENT WITH ATTACHED RATE TARIFFS AND PROOF OF REVENUES; DECLARING EXISTING RATES TO BE UNREASONABLE; ADOPTING TARIFFS THAT REFLECT RATE ADJUSTMENTS CONSISTENT WITH THE NEGOTIATED SETTLEMENT; FINDING THE RATES TO BE SET BY THE SETTLEMENT TARIFFS TO BE JUST AND REASONABLE AND IN THE PUBLIC INTEREST; REQUIRING THE COMPANY TO REIMBURSE ACSC’S REASONABLE RATEMAKING EXPENSES; DETERMINING THAT THIS ORDINANCE WAS PASSED IN ACCORDANCE WITH THE REQUIREMENTS OF THE TEXAS OPEN MEETINGS ACT; ADOPTING A SAVINGS CLAUSE; DECLARING AN EFFECTIVE DATE; AND REQUIRING DELIVERY OF THIS ORDINANCE TO THE COMPANY AND THE ACSC’S LEGAL COUNSEL.**

WHEREAS, the City of Killeen, Texas (“City”) is a gas utility customer of Atmos Energy Corp., Mid-Tex Division (“Atmos Mid-Tex” or “Company”), and a regulatory authority with an interest in the rates and charges of Atmos; and

WHEREAS, the City is a member of the Atmos Cities Steering Committee (“ACSC”), a coalition of similarly-situated cities served by Atmos Mid-Tex (“ACSC Cities”) that have joined together to facilitate the review of and response to natural gas issues affecting rates charged in the Atmos Mid-Tex service area; and

WHEREAS, ACSC and the Company worked collaboratively to develop a new Rate Review Mechanism (“RRM”) tariff that allows for an expedited rate review process by ACSC Cities as a substitute to the Gas Reliability Infrastructure Program (“GRIP”) process instituted by

the Legislature, and that will establish rates for the ACSC Cities based on the system-wide cost of serving the Atmos Mid-Tex Division; and

WHEREAS, the initial RRM Tariff was in effect for four (4) years; and

WHEREAS, ACSC Cities and Atmos Mid-Tex entered into another settlement agreement and revised the RRM Tariff; and

WHEREAS, ACSC Cities and Atmos Mid-Tex compromised and reached agreements on the amount of the rate increases to be in effect for the RRM Tariff filings for 2012 and 2013; and

WHEREAS, ACSC Cities and Atmos Mid-Tex were unable to reach an agreement on the 2014 RRM Tariff filing, resulting in the ACSC Cities' rejection of the 2014 RRM filing; and

WHEREAS, Atmos Mid-Tex appealed the ACSC Cities' actions rejecting its 2014 RRM filing to the Railroad Commission of Texas ("Commission"), pursuant to the provisions of the RRM Tariff; and

WHEREAS, Atmos Mid-Tex and ACSC litigated the appeal of the 2014 RRM filing at the Commission; and

WHEREAS, on February 27, 2015, Atmos Mid-Tex filed its 2015 RRM Tariff filing, requesting to increase natural gas base rates system-wide by \$28.762 million; and

WHEREAS, ACSC coordinated its review of Atmos Mid-Tex RRM filing through its Executive Committee, assisted by ACSC's attorneys and consultants, to resolve issues identified in the Company's RRM filing; and

WHEREAS, Atmos Mid-Tex has agreed to withdraw its appeal of ACSC's rejection of its 2014 RRM Tariff rate increase; and

WHEREAS, the Executive Committee, as well as ACSC's counsel and consultants, recommend that ACSC Cities approve the attached Settlement Agreement (Attachment A to this

Ordinance) as well as the tariffs attached thereto, resolving both the 2014 and the 2015 RRM Tariff filings, which together will increase the Company's revenues by \$65.7 million over the amount allowed under City-approved rates set in 2013; and

WHEREAS, the attached tariffs implementing new rates are consistent with the negotiated Settlement Agreement and are just, reasonable, and in the public interest; and

WHEREAS, the RRM Tariff should be renewed for a period of time commencing in 2016 and continuing until the RRM Tariff is suspended by ordinance of the City; and

WHEREAS, the RRM Tariff contemplates reimbursement of ACSC's reasonable expenses associated with RRM applications;

NOW, THEREFORE, BE IT ORDAINED BY THE CITY COUNCIL OF THE CITY OF KILLEEN, TEXAS:

**Section 1.** That the findings set forth in this Ordinance are hereby in all things approved.

**Section 2.** That the City Council finds that the Settlement Agreement (Attachment A to this Ordinance) represents a comprehensive settlement of gas utility rate issues affecting the rates, operations, and services offered by Atmos Mid-Tex within the municipal limits arising from Atmos Mid-Tex's 2014 and 2015 RRM filings, is in the public interest, and is consistent with the City's authority under Section 103.001 of the Texas Utilities Code.

**Section 3.** That the existing rates for natural gas service provided by Atmos Mid-Tex are unreasonable. The new tariffs attached hereto and incorporated herein as Attachment C, are just and reasonable, and are designed to allow Atmos Mid-Tex to recover annually an additional \$65.7 million in revenue over the amount allowed under currently approved rates, or \$21 million over currently-billed rates, as shown in the Proof of Revenues attached hereto and incorporated herein as Attachment B; such tariffs are hereby adopted.



**Section 4.** That the ratemaking treatment for pensions and other post-employment benefits in Atmos' next RRM filing shall be as set forth on Attachment D, attached hereto and incorporated herein.

**Section 5.** That in an effort to streamline the regulatory review process, the Atmos Mid-Tex RRM Tariff is renewed for a period commencing with the Company's March 1, 2016 RRM filing for calendar year 2015, effective June 1, 2016, and continuing thereafter until such time as the City adopts an ordinance suspending operation of the RRM Tariff.

**Section 6.** That Atmos Mid-Tex shall reimburse the reasonable ratemaking expenses of the ACSC in processing the Company's RRM application.

**Section 7.** That to the extent any resolution or ordinance previously adopted by the Council is inconsistent with this Ordinance, it is hereby repealed.

**Section 8.** That the meeting at which this Ordinance was approved was in all things conducted in strict compliance with the Texas Open Meetings Act, Texas Government Code, Chapter 551.

**Section 9.** That if any one or more sections or clauses of this Ordinance is adjudged to be unconstitutional or invalid, such judgment shall not affect, impair or invalidate the remaining provisions of this Ordinance and the remaining provisions of the Ordinance shall be interpreted as if the offending section or clause never existed.

**Section 10.** That consistent with the City Ordinance that established the RRM process, this Ordinance shall become effective from and after its passage with rates authorized by attached tariffs to be effective for bills rendered on or after June 1, 2015.

**Section 11.** That a copy of this Ordinance shall be sent to Atmos Mid-Tex, care of Chris Felan, Vice President of Rates and Regulatory Affairs Mid-Tex Division, Atmos Energy

Corporation, 5420 LJB Freeway, Suite 1862, Dallas, Texas 75240, and to Geoffrey Gay, General Counsel to ACSC, at Lloyd Gosselink Rochelle & Townsend, P.C., 816 Congress Avenue, Suite 1900, Austin, Texas 78701.

PASSED AND APPROVED this 26<sup>th</sup> day of May, 2015.

---

Scott Coper  
Mayor

ATTEST:

APPROVED AS TO FORM:

---

Dianna Barker  
City Secretary

---

Kathryn H. Davis  
City Attorney

**SETTLEMENT AGREEMENT BETWEEN ATMOS ENERGY CORP., MID-TEX  
DIVISION AND ATMOS CITIES STEERING COMMITTEE**

WHEREAS, this agreement (“Settlement Agreement”) is entered into by Atmos Energy Corp’s Mid-Tex Division and Atmos Cities Steering Committee (“ACSC”) whose members include the Cities of Abilene, Addison, Allen, Alvarado, Angus, Anna, Argyle, Arlington, Aubrey, Bedford, Bellmead, Benbrook, Beverly Hills, Blossom, Blue Ridge, Bowie, Boyd, Bridgeport, Brownwood, Buffalo, Burkburnett, Burleson, Caddo Mills, Canton, Carrollton, Cedar Hill, Celeste, Celina, Centerville, Cisco, Clarksville, Cleburne, Clyde, College Station, Colleyville, Colorado City, Comanche, Commerce, Coolidge, Coppell, Copperas Cove, Corinth, Corral City, Crandall, Crowley, Dalworthington Gardens, Denison, DeSoto, Duncanville, Eastland, Edgecliff Village, Emory, Ennis, Euless, Everman, Fairview, Farmers Branch, Farmersville, Fate, Flower Mound, Forest Hill, Fort Worth, Frisco, Frost, Gainesville, Garland, Garrett, Grand Prairie, Grapevine, Gunter, Haltom City, Harker Heights, Haskell, Haslet, Hewitt, Highland Park, Highland Village, Honey Grove, Hurst, Hutto, Iowa Park, Irving, Justin, Kaufman, Keene, Keller, Kemp, Kennedale, Kerens, Kerrville, Killeen, Krum, Lake Worth, Lakeside, Lancaster, Lewisville, Lincoln Park, Little Elm, Lorena, Madisonville, Malakoff, Mansfield, McKinney, Melissa, Mesquite, Midlothian, Murphy, Newark, Nocona, North Richland Hills, Northlake, Oakleaf, Ovilla, Palestine, Pantego, Paris, Parker, Pecan Hill, Petrolia, Plano, Ponder, Pottsboro, Prosper, Quitman, Red Oak, Reno (Parker County), Richardson, Richland, Richland Hills, Roanoke, Robinson, Rockwall, Roscoe, Rowlett, Royse City, Sachse, Saginaw, Sansom Park, Seagoville, Sherman, Snyder, Southlake, Springtown, Stamford, Stephenville, Sulphur Springs, Sweetwater, Temple, Terrell, The Colony, Trophy Club, Tyler, University Park, Venus, Vernon, Waco, Watauga, Waxahachie, Westlake, White Settlement, Whitesboro, Wichita Falls, Woodway, and Wylie.

WHEREAS, on February 28, 2014, Atmos filed with the ACSC Cities an application, hereinafter referred to as the 2014 RRM filing, to adjust rates pursuant to Rider RRM - Rate Review Mechanism, which were subsequently consolidated into GUD No. 10359 at the Railroad Commission of Texas; and

WHEREAS, on February 27, 2015, Atmos filed with the ACSC Cities an application, hereinafter referred to as the 2015 RRM filing, to adjust rates pursuant to Rider RRM - Rate Review Mechanism; and

WHEREAS, the Settlement Agreement resolves all issues between Atmos and ACSC (“the Signatories”) regarding the 2014 RRM filing, which is currently pending before the Commission, and the 2015 RRM filing, which is currently pending before the ACSC Cities, in a manner that the Signatories believe is consistent with the public interest, and the Signatories represent diverse interests; and

WHEREAS, the Signatories believe that the resolution of the issues raised in the 2014 RRM filing and the 2015 RRM filing can best be accomplished by each ACSC City approving this Settlement Agreement and the rates, terms and conditions reflected in the tariffs attached to this Settlement Agreement as Exhibit A;

NOW, THEREFORE, in consideration of the mutual agreements and covenants established herein, the Signatories, through their undersigned representatives, agree to the

## Attachment A

following Settlement Terms as a means of fully resolving all issues between Atmos and the ACSC Cities involving the 2014 RRM filing and 2015 RRM filing:

### Settlement Terms

1. Upon the execution of this Settlement Agreement, the ACSC Cities will approve an ordinance or resolution to approve the Settlement Agreement and implement the rates, terms and conditions reflected in the tariffs attached to the Settlement Agreement as Exhibit A. (Attachment A to the Ordinance ratifying the Agreement). Said tariffs should allow Atmos to recover annually an additional \$65.7 million in revenue over the amount allowed under currently approved rates by implementation of rates shown in the proof of revenues attached as Exhibit B. (Attachment B to the Ordinance ratifying this Agreement). The uniform implementation of gas rates, terms and conditions established by the Settlement Agreement shall be effective for bills rendered on or after June 1, 2015. Consistent with the City's authority under Section 103.001 of the Texas Utilities Code, the Settlement Agreement represents a comprehensive settlement of gas utility rate issues affecting the rates, operations and services offered by Atmos within the municipal limits of the ACSC Cities arising from Atmos' 2014 RRM filing and 2015 RRM filing. No refunds of charges billed to customers by Atmos under the RRM in past periods shall be owed or owing.
2. In an effort to streamline the regulatory review process, Atmos and the ACSC Cities have agreed to renew the Rate Review Mechanism ("Rider RRM") for a period commencing with the Company's March 1, 2016 filing under this mechanism for the calendar year 2015, effective June 1, 2016, and continuing thereafter until such time as either the ACSC Cities issue an ordinance stating a desire to discontinue the operation of the tariff or Atmos files a Statement of Intent. Atmos and the ACSC Cities further agree that the RRM tariff shall remain in effect until such time as new, final rates are established for Atmos. Upon approval of this Settlement Agreement by the ACSC Cities, Atmos shall file an updated RRM Tariff with each city reflecting the provisions of this agreement.
3. Atmos and the ACSC Cities agree that rate base as of December 31, 2014 in the amount of \$1,955,948,256 is just and reasonable and shall be recovered in rates.
4. Atmos and the ACSC Cities agree that a pension and other postemployment benefits balance as of December 31, 2014 in the amount of \$18,284,949 is just and reasonable and shall be used as the beginning balance for purposes of determining pension and other postemployment benefits to be recovered in the next RRM filing (Attachment D to the Ordinance ratifying the Agreement).
5. With regard to the treatment of Atmos' Rule 8.209 regulatory asset under the RRM, Atmos and the ACSC Cities agree to the following with respect to any pending and future RRM filings:
  - a. the capital investment in the Rule 8.209 regulatory asset in the 2014 RRM filing and 2015 RRM filing is reasonable and consistent with the requirements of Rule 8.209;

## Attachment A

- b. the classification of projects included in the Rule 8.209 regulatory asset in the 2014 RRM filing and 2015 RRM filing is reasonable and consistent with the requirements of Rule 8.209 and shall serve as a basis for classification of projects in future RRM filings;
  - c. the treatment of blanket replacement projects, system upgrades, relocations, and transmission line replacements in the Rule 8.209 regulatory asset in the 2014 RRM filing and 2015 RRM filing is reasonable and consistent with the requirements of Rule 8.209 and shall be included in future RRM filings.
  - d. the incurred expenses included in the Rule 8.209 regulatory asset in the 2014 RRM and the 2015 RRM are reasonable and consistent with the requirements of Rule 8.209 and shall be included in future RRM filings;
  - e. interest on the Rule 8.209 regulatory asset account shall be calculated using the pre-tax cost of capital most recently approved by the Commission. The use of the pre-tax cost of capital is consistent with Rule 8.209. A return on Rule 8.209 capital investment is only earned once the investment is included in rate base. No change in the Company's calculation of the interest component in its Rule 8.209 regulatory asset accounts is warranted through the period ended May 31, 2015. Beginning June 1, 2015, interest expense shall be calculated monthly using simple interest (*i.e.* 11.49% divided by 12, or approximately 0.96% per month) applied to the total value of the Rule 8.209 asset investment (exclusive of interest) until such time the Rule 8.209 regulatory asset is approved for inclusion in the Company's rate base.
  - f. While Atmos and the ACSC Cities agree to apply the treatments and methodologies set forth in this paragraph, subsections (a) – (e) in all future RRM filings, the regulatory authority retains its right to disallow any capital investment that is not shown to be prudently incurred, and any expense not shown to be reasonable and necessary, in future RRM filings.
  - g. Atmos and the ACSC Cities acknowledge that their agreement regarding the treatment and methodologies applicable to Rule 8.209 capital investments under the RRM tariff shall not prejudice the right of either party to argue for different treatments or methodologies in a future statement of intent proceeding.
6. Revenues approved pursuant to Paragraph 1 of the Settlement Agreement include reimbursement of rate case expenses owed to the ACSC Cities in connection with the 2014 RRM filing.
  7. The Signatories agree that each ACSC city shall approve this Settlement Agreement and adopt an ordinance or resolution to implement for the ACSC Cities the rates, terms, and conditions reflected in the tariffs attached to the Settlement Agreement as Exhibit A. Atmos and ACSC further agree that at such time as all of the ACSC Cities have passed an ordinance or resolution consistent with the Settlement and Atmos has received such ordinance or resolution, Atmos shall withdraw its appeal of the currently pending RRM filing before the Railroad Commission of Texas in connection with the 2014 RRM filing.

8. Atmos and the ACSC Cities further agree that the express terms of the Rider RRM are supplemental to the filing, notice, regulatory review, or appellate procedural process of the ratemaking provisions of Chapter 104 of the Texas Utilities Code. If the statute requires a mandatory action on behalf of the municipal regulatory authority or Atmos, the parties will follow the provisions of such statute. If the statute allows discretion on behalf of the municipal regulatory authority, the ACSC Cities agree that they shall exercise such discretion in such a way as to implement the provisions of the RRM tariff. If Atmos appeals an action or inaction of an ACSC City regarding an RRM filing to the Railroad Commission, the ACSC Cities agree that they will not oppose the implementation of interim rates or advocate the imposition of a bond by Atmos consistent with the RRM tariff. Atmos agrees that it will make no filings on behalf of its Mid-Tex Division under the provisions of Section 104.301 of the Texas Utilities code while the Rider RRM is in place. In the event that a regulatory authority fails to act or enters an adverse decision regarding the proposed annual RRM adjustment, the Railroad Commission of Texas shall have exclusive appellate jurisdiction, pursuant to the provisions of the Texas Utilities Code, to review the action or inaction of the regulatory authority exercising exclusive original jurisdiction over the RRM request. In addition, the Signatories agree that this Settlement Agreement shall not be construed as a waiver of the ACSC Cities' right to initiate a show cause proceeding or the Company's right to file a Statement of Intent under the provisions of the Texas Utilities Code.
9. The Signatories agree that the terms of the Settlement Agreement are interdependent and indivisible, and that if any ACSC city enters an order that is inconsistent with this Settlement Agreement, then any Signatory may withdraw without being deemed to have waived any procedural right or to have taken any substantive position on any fact or issue by virtue of that Signatory's entry into the Settlement Agreement or its subsequent withdrawal. If any ACSC city rejects this Settlement Agreement, then this Settlement Agreement shall be void *ab initio* and counsel for the ACSC Cities shall thereafter only take such actions as are in accordance with the Texas Disciplinary Rules of Professional Conduct.
10. The Signatories agree that all negotiations, discussions and conferences related to the Settlement Agreement are privileged, inadmissible, and not relevant to prove any issues associated with Atmos' 2014 RRM filing and 2015 RRM filing.
11. The Signatories agree that neither this Settlement Agreement nor any oral or written statements made during the course of settlement negotiations may be used for any purpose other than as necessary to support the entry by the ACSC Cities of an ordinance or resolution implementing this Settlement Agreement.
12. The Signatories agree that this Settlement Agreement is binding on each Signatory only for the purpose of settling the issues set forth herein and for no other purposes, and, except to the extent the Settlement Agreement governs a Signatory's rights and obligations for future periods, this Settlement Agreement shall not be binding or precedential upon a Signatory outside this proceeding.

Attachment A

13. The Signatories agree that this Settlement Agreement may be executed in multiple counterparts and may be filed with facsimile signatures.

Agreed to this 7 day of May, 2015.

ATMOS ENERGY CORP., MID-TEX DIVISION

By: John A. Paris  
John A. Paris  
President, Mid-Tex Division



Attachment A

Agreed to this 7th day of May 2015.

ATTORNEY FOR ATMOS CITIES STEERING COMMITTEE, WHOSE MEMBERS INCLUDE THE CITIES OF ABILENE, ADDISON, ALLEN, ALVARADO, ANGUS, ANNA, ARGYLE, ARLINGTON, AUBREY, BEDFORD, BELLMEAD, BENBROOK, BEVERLY HILLS, BLOSSOM, BLUE RIDGE, BOWIE, BOYD, BRIDGEPORT, BROWNWOOD, BUFFALO, BURKBURNETT, BURLESON, CADDO MILLS, CANTON, CARROLLTON, CEDAR HILL, CELESTE, CELINA, CENTERVILLE, CISCO, CLARKSVILLE, CLEBURNE, CLYDE, COLLEGE STATION, COLLEYVILLE, COLORADO CITY, COMANCHE, COMMERCE, COOLIDGE, COPPELL, COPPERAS COVE, CORINTH, CORRAL CITY, CRANDALL, CROWLEY, DALWORTHINGTON GARDENS, DENISON, DESOTO, DUNCANVILLE, EASTLAND, EDGECLIFF VILLAGE, EMORY, ENNIS, EULESS, EVERMAN, FAIRVIEW, FARMERS BRANCH, FARMERSVILLE, FATE, FLOWER MOUND, FOREST HILL, FORT WORTH, FRISCO, FROST, GAINESVILLE, GARLAND, GARRETT, GRAND PRAIRIE, GRAPEVINE, GUNTER, HALTOM CITY, HARKER HEIGHTS, HASKELL, HASLET, HEWITT, HIGHLAND PARK, HIGHLAND VILLAGE, HONEY GROVE, HURST, HUTTO, IOWA PARK, IRVING, JUSTIN, KAUFMAN, KEENE, KELLER, KEMP, KENNEDALE, KERENS, KERRVILLE, KILLEEN, KRUM, LAKE WORTH, LAKESIDE, LANCASTER, LEWISVILLE, LINCOLN PARK, LITTLE ELM, LORENA, MADISONVILLE, MALAKOFF, MANSFIELD, MCKINNEY, MELISSA, MESQUITE, MIDLOTHIAN, MURPHY, NEWARK, NOCONA, NORTH RICHLAND HILLS, NORTHLAKE, OAKLEAF, OVILLA, PALESTINE, PANTEGO, PARIS, PARKER, PECAN HILL, PETROLIA, PLANO, PONDER, POTTSBORO, PROSPER, QUITMAN, RED OAK, RENO (PARKER COUNTY), RICHARDSON, RICHLAND, RICHLAND HILLS, ROANOKE, ROBINSON, ROCKWALL, ROSCOE, ROWLETT, ROYSE CITY, SACHSE, SAGINAW, SANSOM PARK, SEAGOVILLE, SHERMAN, SNYDER, SOUTHLAKE, SPRINGTOWN, STAMFORD, STEPHENVILLE, SULPHUR SPRINGS, SWEETWATER, TEMPLE, TERRELL, THE COLONY, TROPHY CLUB, TYLER, UNIVERSITY PARK, VENUS, VERNON, WACO, WATAUGA, WAXAHACHIE, WESTLAKE, WHITE SETTLEMENT, WHITESBORO, WICHITA FALLS, WOODWAY, AND WYLIE.

By:   
Geoffrey Gay\*

\* Subject to approval by ACSC City Councils

**MID-TEX DIVISION  
ATMOS ENERGY CORPORATION**

**RRC Tariff No:**

<b>RATE SCHEDULE:</b>	<b>C – COMMERCIAL SALES</b>	
<b>APPLICABLE TO:</b>	<b>ALL CUSTOMERS IN THE MID-TEX DIVISION EXCEPT THE CITY OF DALLAS AND UNINCORPORATED AREAS</b>	
<b>EFFECTIVE DATE:</b>	<b>Bills Rendered on or after 06/01/2015</b>	<b>PAGE:</b>

**Application**

Applicable to Commercial Customers for all natural gas provided at one Point of Delivery and measured through one meter and to Industrial Customers with an average annual usage of less than 30,000 Ccf.

**Type of Service**

Where service of the type desired by Customer is not already available at the Point of Delivery, additional charges and special contract arrangements between Company and Customer may be required prior to service being furnished.

**Monthly Rate**

Customer's monthly bill will be calculated by adding the following Customer and Ccf charges to the amounts due under the riders listed below:

<b>Charge</b>	<b>Amount</b>
Customer Charge per Bill	\$ 40.00 per month
Rider CEE Surcharge	\$ 0.00 per month <sup>1</sup>
<b>Total Customer Charge</b>	<b>\$ 40.00 per month</b>
Commodity Charge – All Ccf	\$ 0.08020 per Ccf

Gas Cost Recovery: Plus an amount for gas costs and upstream transportation costs calculated in accordance with Part (a) and Part (b), respectively, of Rider GCR.

Weather Normalization Adjustment: Plus or Minus an amount for weather normalization calculated in accordance with Rider WNA.

Franchise Fee Adjustment: Plus an amount for franchise fees calculated in accordance with Rider FF. Rider FF is only applicable to customers inside the corporate limits of any incorporated municipality.

Tax Adjustment: Plus an amount for tax calculated in accordance with Rider TAX.

Surcharges: Plus an amount for surcharges calculated in accordance with the applicable rider(s).

**Agreement**

An Agreement for Gas Service may be required.

**Notice**

Service hereunder and the rates for services provided are subject to the orders of regulatory bodies having jurisdiction and to the Company's Tariff for Gas Service.

<sup>1</sup> Reference Rider CEE - Conservation And Energy Efficiency as approved in GUD 10170. Surcharge billing effective July 1, 2014.

**MID-TEX DIVISION  
ATMOS ENERGY CORPORATION**

**RRC Tariff No:**

<b>RATE SCHEDULE:</b>	<b>I – INDUSTRIAL SALES</b>	
<b>APPLICABLE TO:</b>	<b>ALL CUSTOMERS IN THE MID-TEX DIVISION EXCEPT THE CITY OF DALLAS AND UNINCORPORATED AREAS</b>	
<b>EFFECTIVE DATE:</b>	<b>Bills Rendered on or after 06/01/2015</b>	<b>PAGE:</b>

**Application**

Applicable to Industrial Customers with a maximum daily usage (MDU) of less than 3,500 MMBtu per day for all natural gas provided at one Point of Delivery and measured through one meter. Service for Industrial Customers with an MDU equal to or greater than 3,500 MMBtu per day will be provided at Company's sole option and will require special contract arrangements between Company and Customer.

**Type of Service**

Where service of the type desired by Customer is not already available at the Point of Delivery, additional charges and special contract arrangements between Company and Customer may be required prior to service being furnished.

**Monthly Rate**

Customer's monthly bill will be calculated by adding the following Customer and MMBtu charges to the amounts due under the riders listed below:

<b>Charge</b>	<b>Amount</b>
Customer Charge per Meter	\$ 700.00 per month
First 0 MMBtu to 1,500 MMBtu	\$ 0.2937 per MMBtu
Next 3,500 MMBtu	\$ 0.2151 per MMBtu
All MMBtu over 5,000 MMBtu	\$ 0.0461 per MMBtu

Gas Cost Recovery: Plus an amount for gas costs and upstream transportation costs calculated in accordance with Part (a) and Part (b), respectively, of Rider GCR.

Franchise Fee Adjustment: Plus an amount for franchise fees calculated in accordance with Rider FF. Rider FF is only applicable to customers inside the corporate limits of any incorporated municipality.

Tax Adjustment: Plus an amount for tax calculated in accordance with Rider TAX.

Surcharges: Plus an amount for surcharges calculated in accordance with the applicable rider(s).

**Curtailement Overpull Fee**

Upon notification by Company of an event of curtailement or interruption of Customer's deliveries, Customer will, for each MMBtu delivered in excess of the stated level of curtailement or interruption, pay Company 200% of the midpoint price for the Katy point listed in *Platts Gas Daily* published for the applicable Gas Day in the table entitled "Daily Price Survey."

**Replacement Index**

In the event the "midpoint" or "common" price for the Katy point listed in *Platts Gas Daily* in the table entitled "Daily Price Survey" is no longer published, Company will calculate the applicable imbalance fees utilizing a daily price index recognized as authoritative by the natural gas industry and most closely approximating the applicable index.

**MID-TEX DIVISION  
ATMOS ENERGY CORPORATION**

**RRC Tariff No:**

<b>RATE SCHEDULE:</b>	<b>I – INDUSTRIAL SALES</b>	
<b>APPLICABLE TO:</b>	<b>ALL CUSTOMERS IN THE MID-TEX DIVISION EXCEPT THE CITY OF DALLAS AND UNINCORPORATED AREAS</b>	
<b>EFFECTIVE DATE:</b>	<b>Bills Rendered on or after 06/01/2015</b>	<b>PAGE:</b>

**Agreement**

An Agreement for Gas Service may be required.

**Notice**

Service hereunder and the rates for services provided are subject to the orders of regulatory bodies having jurisdiction and to the Company's Tariff for Gas Service.

**Special Conditions**

In order to receive service under Rate I, Customer must have the type of meter required by Company. Customer must pay Company all costs associated with the acquisition and installation of the meter.

**MID-TEX DIVISION  
ATMOS ENERGY CORPORATION**

**RRC Tariff No:**

<b>RATE SCHEDULE:</b>	<b>R – RESIDENTIAL SALES</b>	
<b>APPLICABLE TO:</b>	<b>ALL CUSTOMERS IN THE MID-TEX DIVISION EXCEPT THE CITY OF DALLAS AND UNINCORPORATED AREAS</b>	
<b>EFFECTIVE DATE:</b>	<b>Bills Rendered on or after 06/01/2015</b>	<b>PAGE:</b>

**Application**

Applicable to Residential Customers for all natural gas provided at one Point of Delivery and measured through one meter.

**Type of Service**

Where service of the type desired by Customer is not already available at the Point of Delivery, additional charges and special contract arrangements between Company and Customer may be required prior to service being furnished.

**Monthly Rate**

Customer's monthly bill will be calculated by adding the following Customer and Ccf charges to the amounts due under the riders listed below:

<b>Charge</b>	<b>Amount</b>
Customer Charge per Bill	\$ 18.60 per month
Rider CEE Surcharge	\$ 0.02 per month <sup>1</sup>
<b>Total Customer Charge</b>	<b>\$ 18.62 per month</b>
Commodity Charge – All <u>Ccf</u>	\$0.09931 per Ccf

Gas Cost Recovery: Plus an amount for gas costs and upstream transportation costs calculated in accordance with Part (a) and Part (b), respectively, of Rider GCR.

Weather Normalization Adjustment: Plus or Minus an amount for weather normalization calculated in accordance with Rider WNA.

Franchise Fee Adjustment: Plus an amount for franchise fees calculated in accordance with Rider FF. Rider FF is only applicable to customers inside the corporate limits of any incorporated municipality.

Tax Adjustment: Plus an amount for tax calculated in accordance with Rider TAX.

Surcharges: Plus an amount for surcharges calculated in accordance with the applicable rider(s).

**Agreement**

An Agreement for Gas Service may be required.

**Notice**

Service hereunder and the rates for services provided are subject to the orders of regulatory bodies having jurisdiction and to the Company's Tariff for Gas Service.

<sup>1</sup>Reference Rider CEE - Conservation And Energy Efficiency as approved in GUD 10170. Surcharge billing effective July 1, 2014.

**MID-TEX DIVISION  
ATMOS ENERGY CORPORATION**

**RRC Tariff No:**

<b>RATE SCHEDULE:</b>	<b>T – TRANSPORTATION</b>	
<b>APPLICABLE TO:</b>	<b>ALL CUSTOMERS IN THE MID-TEX DIVISION EXCEPT THE CITY OF DALLAS AND UNINCORPORATED AREAS</b>	
<b>EFFECTIVE DATE:</b>	<b>Bills Rendered on or after 06/01/2015</b>	<b>PAGE:</b>

**Application**

Applicable, in the event that Company has entered into a Transportation Agreement, to a customer directly connected to the Atmos Energy Corp., Mid-Tex Division Distribution System (Customer) for the transportation of all natural gas supplied by Customer or Customer's agent at one Point of Delivery for use in Customer's facility.

**Type of Service**

Where service of the type desired by Customer is not already available at the Point of Delivery, additional charges and special contract arrangements between Company and Customer may be required prior to service being furnished.

**Monthly Rate**

Customer's bill will be calculated by adding the following Customer and MMBtu charges to the amounts and quantities due under the riders listed below:

<b>Charge</b>	<b>Amount</b>
Customer Charge per Meter	\$ 700.00 per month
First 0 MMBtu to 1,500 MMBtu	\$ 0.2937 per MMBtu
Next 3,500 MMBtu	\$ 0.2151 per MMBtu
All MMBtu over 5,000 MMBtu	\$ 0.0461 per MMBtu

Upstream Transportation Cost Recovery: Plus an amount for upstream transportation costs in accordance with Part (b) of Rider GCR.

Retention Adjustment: Plus a quantity of gas as calculated in accordance with Rider RA.

Franchise Fee Adjustment: Plus an amount for franchise fees calculated in accordance with Rider FF. Rider FF is only applicable to customers inside the corporate limits of any incorporated municipality.

Tax Adjustment: Plus an amount for tax calculated in accordance with Rider TAX.

Surcharges: Plus an amount for surcharges calculated in accordance with the applicable rider(s).

**Imbalance Fees**

All fees charged to Customer under this Rate Schedule will be charged based on the quantities determined under the applicable Transportation Agreement and quantities will not be aggregated for any Customer with multiple Transportation Agreements for the purposes of such fees.

**Monthly Imbalance Fees**

Customer shall pay Company the greater of (i) \$0.10 per MMBtu, or (ii) 150% of the difference per MMBtu between the highest and lowest "midpoint" price for the Katy point listed in *Platts Gas Daily* in the table entitled "Daily Price Survey" during such month, for the MMBtu of Customer's monthly Cumulative Imbalance, as defined in the applicable Transportation Agreement, at the end of each month that exceeds 10% of Customer's receipt quantities for the month.

**MID-TEX DIVISION  
ATMOS ENERGY CORPORATION**

**RRC Tariff No:**

<b>RATE SCHEDULE:</b>	<b>T – TRANSPORTATION</b>	
<b>APPLICABLE TO:</b>	<b>ALL CUSTOMERS IN THE MID-TEX DIVISION EXCEPT THE CITY OF DALLAS AND UNINCORPORATED AREAS</b>	
<b>EFFECTIVE DATE:</b>	<b>Bills Rendered on or after 06/01/2015</b>	<b>PAGE:</b>

**Curtailement Overpull Fee**

Upon notification by Company of an event of curtailment or interruption of Customer's deliveries, Customer will, for each MMBtu delivered in excess of the stated level of curtailment or interruption, pay Company 200% of the midpoint price for the Katy point listed in *Platts Gas Daily* published for the applicable Gas Day in the table entitled "Daily Price Survey."

**Replacement Index**

In the event the "midpoint" or "common" price for the Katy point listed in *Platts Gas Daily* in the table entitled "Daily Price Survey" is no longer published, Company will calculate the applicable imbalance fees utilizing a daily price index recognized as authoritative by the natural gas industry and most closely approximating the applicable index.

**Agreement**

A transportation agreement is required.

**Notice**

Service hereunder and the rates for services provided are subject to the orders of regulatory bodies having jurisdiction and to the Company's Tariff for Gas Service.

**Special Conditions**

In order to receive service under Rate T, customer must have the type of meter required by Company. Customer must pay Company all costs associated with the acquisition and installation of the meter.

**MID-TEX DIVISION  
ATMOS ENERGY CORPORATION**

<b>RIDER:</b>	<b>WNA – WEATHER NORMALIZATION ADJUSTMENT</b>	
<b>APPLICABLE TO:</b>	<b>ALL CUSTOMERS IN THE MID-TEX DIVISION EXCEPT THE CITY OF DALLAS AND UNINCORPORATED AREAS</b>	
<b>EFFECTIVE DATE:</b>	<b>Bills Rendered on or after 11/01/2015</b>	<b>PAGE:</b>

Provisions for Adjustment

The Commodity Charge per Ccf (100 cubic feet) for gas service set forth in any Rate Schedules utilized by the cities of the Mid-Tex Division service area for determining normalized winter period revenues shall be adjusted by an amount hereinafter described, which amount is referred to as the "Weather Normalization Adjustment." The Weather Normalization Adjustment shall apply to all temperature sensitive residential and commercial bills based on meters read during the revenue months of November through April. The five regional weather stations are Abilene, Austin, Dallas, Waco, and Wichita Falls.

Computation of Weather Normalization Adjustment

The Weather Normalization Adjustment Factor shall be computed to the nearest one-hundredth cent per Ccf by the following formula:

$$WNAF_i = R_i \frac{(HSF_i \times (NDD-ADD))}{(BL_i + (HSF_i \times ADD))}$$

Where

- $i$  = any particular Rate Schedule or billing classification within any such particular Rate Schedule that contains more than one billing classification
- $WNAF_i$  = Weather Normalization Adjustment Factor for the  $i^{th}$  rate schedule or classification expressed in cents per Ccf
- $R_i$  = Commodity Charge rate of temperature sensitive sales for the  $i^{th}$  schedule or classification.
- $HSF_i$  = heat sensitive factor for the  $i^{th}$  schedule or classification divided by the average bill count in that class
- $NDD$  = billing cycle normal heating degree days calculated as the simple ten-year average of actual heating degree days.
- $ADD$  = billing cycle actual heating degree days.
- $BL_i$  = base load sales for the  $i^{th}$  schedule or classification divided by the average bill count in that class

The Weather Normalization Adjustment for the  $j$ th customer in  $i$ th rate schedule is computed as:

$$WNA_j = WNAF_i \times q_{ij}$$

Where  $q_{ij}$  is the relevant sales quantity for the  $j$ th customer in  $i$ th rate schedule.



**MID-TEX DIVISION  
ATMOS ENERGY CORPORATION**

<b>RIDER:</b>	<b>WNA – WEATHER NORMALIZATION ADJUSTMENT</b>	
<b>APPLICABLE TO:</b>	<b>ALL CUSTOMERS IN THE MID-TEX DIVISION EXCEPT THE CITY OF DALLAS AND UNINCORPORATED AREAS</b>	
<b>EFFECTIVE DATE:</b>	<b>Bills Rendered on or after 11/01/2015</b>	<b>PAGE:</b>

Base Use/Heat Use Factors

Weather Station	<u>Residential</u>		<u>Commercial</u>	
	Base use <u>Ccf</u>	Heat use <u>Ccf/HDD</u>	Base use <u>Ccf</u>	Heat use <u>Ccf/HDD</u>
Abilene	10.22	0.1404	98.80	0.6372
Austin	11.59	0.1443	213.62	0.7922
Dallas	14.12	0.2000	208.11	0.9085
Waco	9.74	0.1387	130.27	0.6351
Wichita Falls	11.79	0.1476	122.35	0.5772

Weather Normalization Adjustment (WNA) Report

On or before June 1 of each year, the company posts on its website at [atmosenergy.com/mtx-wna](http://atmosenergy.com/mtx-wna), in Excel format, a *Weather Normalization Adjustment (WNA) Report* to show how the company calculated its WNAs factor during the preceding winter season. Additionally, on or before June 1 of each year, the company files one hard copy and a Excel version of the *WNA Report* with the Railroad Commission of Texas' Gas Services Division, addressed to the Director of that Division.

ATMOS ENERGY CORP., MID-TEX DIVISION  
 PROOF OF REVENUES AND PROPOSED TARIFF STRUCTURE  
 TEST YEAR ENDING DECEMBER 31, 2014

(a)	(b)	(c)	(d)	(e)	(f)	(g)
1	Proposed Change In Rates:	\$21,066,527	Schedule A			
2	Proposed Change In Rates without Revenue Related Taxes:	\$19,757,254	Ln 1 divided by factor on WP_F-5.1			
3						
4						
5						
6						
7	Residential	Revenue Requirements	Allocations			
8	Commercial	\$ 338,431,486	77.95%	Per GUD 10170 Final Order		
9	Industrial and Transportation	\$ 84,223,622	19.40%	Per GUD 10170 Final Order		
10	Net Revenue Requirements GUD No. 10170	\$ 11,490,316	2.65%	Per GUD 10170 Final Order		
11		\$ 434,145,424				
12						
17						
18						
19						
20	Residential Base Charge	Current	Proposed Change	Proposed Rates	Proposed Change In Revenues	Proposed Rates with Rate Case Expenses
21	Residential Consumption Charge	\$ 18.20	\$ 0.36	\$ 18.56	\$ 6,351,350	\$ 18.60
22	Commercial Base Charge	\$ 0.08819	\$ 0.01112	\$ 0.09931	\$ 9,049,383	\$ 0.09931
23	Commercial Consumption Charge	\$ 38.50	\$ 1.37	\$ 39.87	\$ 2,000,584	\$ 40.00
24	I&T Base Charge	\$ 0.07681	\$ 0.00339	\$ 0.08020	\$ 1,834,968	\$ 0.08020
25	I&T Consumption Charge Tier 1 MMBTU	\$ 675.00	\$ 22.35	\$ 697.35	\$ 220,192	\$ 700.00
26	I&T Consumption Charge Tier 2 MMBTU	\$ 0.2807	\$ 0.0130	\$ 0.2937	\$ 142,055	\$ 0.2937
27	I&T Consumption Charge Tier 3 MMBTU	\$ 0.2056	\$ 0.0095	\$ 0.2151	\$ 117,051	\$ 0.2151
28		\$ 0.0441	\$ 0.0020	\$ 0.0461	\$ 42,703	\$ 0.0461
29				\$	\$ 19,758,287	\$ 523,612,169

Data Sources:  
 GUD10170\_FINAL.xlsm

ATMOS ENERGY CORP., MID-TEX DIVISION  
 PROOF OF REVENUES AND PROPOSED TARIFF STRUCTURE  
 TEST YEAR ENDING DECEMBER 31, 2014

(a) (b) (c) (d) (e) (f) (g)

1 Proposed Change In Rates: \$21,066,527 Schedule A  
 2 Proposed Change In Rates without Revenue Related Taxes: \$19,757,254 Ln 1 divided by factor on WP\_F-5.1

Revenue Requirements	Allocations
\$ 338,431,486	77.95% Per GUD 10170 Final Order
\$ 84,223,622	19.40% Per GUD 10170 Final Order
\$ 11,490,316	2.65% Per GUD 10170 Final Order
<u>\$ 434,145,424</u>	

Rate Class	Current	Proposed Change	Proposed Rates	Proposed Change In Revenues	Proposed Revenues	Proposed Rates with Rate Case Expenses
20 Residential Base Charge	\$ 18.20	\$ 0.36	\$ 18.56	\$ 6,351,350	\$ 327,447,398	\$ 18.60
21 Residential Consumption Charge	\$ 0.08819	\$ 0.01112	\$ 0.09931	\$ 9,049,383	\$ 80,817,829	\$ 0.09931
22 Commercial Base Charge	\$ 38.50	\$ 1.37	\$ 39.87	\$ 2,000,584	\$ 58,221,364	\$ 40.00
23 Commercial Consumption Charge	\$ 0.07681	\$ 0.00339	\$ 0.08020	\$ 1,834,968	\$ 43,411,339	\$ 0.08020
24 I&T Base Charge	\$ 675.00	\$ 22.35	\$ 697.35	\$ 220,192	\$ 6,870,292	\$ 700.00
25 I&T Consumption Charge Tier 1 MMBTU	\$ 0.2807	\$ 0.0130	\$ 0.2937	\$ 142,055	\$ 3,209,350	\$ 0.2937
26 I&T Consumption Charge Tier 2 MMBTU	\$ 0.2056	\$ 0.0095	\$ 0.2151	\$ 117,051	\$ 2,650,282	\$ 0.2151
27 I&T Consumption Charge Tier 3 MMBTU	\$ 0.0441	\$ 0.0020	\$ 0.0461	\$ 42,703	\$ 984,314	\$ 0.0461
28				\$ 19,758,287	\$ 523,612,169	
29						

Data Sources:  
 GUD10170\_FINAL.xlsm

<b>RATE SCHEDULE:</b>	<b>C – COMMERCIAL SALES</b>	
<b>APPLICABLE TO:</b>	<b>ALL CUSTOMERS IN THE MID-TEX DIVISION EXCEPT THE CITY OF DALLAS AND UNINCORPORATED AREAS</b>	
<b>EFFECTIVE DATE:</b>	<b>Bills Rendered on or after 06/01/2015</b>	<b>PAGE:</b>

**Application**

Applicable to Commercial Customers for all natural gas provided at one Point of Delivery and measured through one meter and to Industrial Customers with an average annual usage of less than 30,000 Ccf.

**Type of Service**

Where service of the type desired by Customer is not already available at the Point of Delivery, additional charges and special contract arrangements between Company and Customer may be required prior to service being furnished.

**Monthly Rate**

Customer's monthly bill will be calculated by adding the following Customer and Ccf charges to the amounts due under the riders listed below:

<b>Charge</b>	<b>Amount</b>
Customer Charge per Bill	\$ 40.00 per month
Rider CEE Surcharge	\$ 0.00 per month <sup>1</sup>
<b>Total Customer Charge</b>	<b>\$ 40.00 per month</b>
Commodity Charge – All Ccf	\$ 0.08020 per Ccf

Gas Cost Recovery: Plus an amount for gas costs and upstream transportation costs calculated in accordance with Part (a) and Part (b), respectively, of Rider GCR.

Weather Normalization Adjustment: Plus or Minus an amount for weather normalization calculated in accordance with Rider WNA.

Franchise Fee Adjustment: Plus an amount for franchise fees calculated in accordance with Rider FF. Rider FF is only applicable to customers inside the corporate limits of any incorporated municipality.

Tax Adjustment: Plus an amount for tax calculated in accordance with Rider TAX.

Surcharges: Plus an amount for surcharges calculated in accordance with the applicable rider(s).

**Agreement**

An Agreement for Gas Service may be required.

**Notice**

Service hereunder and the rates for services provided are subject to the orders of regulatory bodies having jurisdiction and to the Company's Tariff for Gas Service.

<sup>1</sup> Reference Rider CEE - Conservation And Energy Efficiency as approved in GUD 10170. Surcharge billing effective July 1, 2014.

<b>RATE SCHEDULE:</b>	<b>I – INDUSTRIAL SALES</b>	
<b>APPLICABLE TO:</b>	<b>ALL CUSTOMERS IN THE MID-TEX DIVISION EXCEPT THE CITY OF DALLAS AND UNINCORPORATED AREAS</b>	
<b>EFFECTIVE DATE:</b>	<b>Bills Rendered on or after 06/01/2015</b>	<b>PAGE:</b>

**Application**

Applicable to Industrial Customers with a maximum daily usage (MDU) of less than 3,500 MMBtu per day for all natural gas provided at one Point of Delivery and measured through one meter. Service for Industrial Customers with an MDU equal to or greater than 3,500 MMBtu per day will be provided at Company's sole option and will require special contract arrangements between Company and Customer.

**Type of Service**

Where service of the type desired by Customer is not already available at the Point of Delivery, additional charges and special contract arrangements between Company and Customer may be required prior to service being furnished.

**Monthly Rate**

Customer's monthly bill will be calculated by adding the following Customer and MMBtu charges to the amounts due under the riders listed below:

<b>Charge</b>	<b>Amount</b>
Customer Charge per Meter	\$ 700.00 per month
First 0 MMBtu to 1,500 MMBtu	\$ 0.2937 per MMBtu
Next 3,500 MMBtu	\$ 0.2151 per MMBtu
All MMBtu over 5,000 MMBtu	\$ 0.0461 per MMBtu

Gas Cost Recovery: Plus an amount for gas costs and upstream transportation costs calculated in accordance with Part (a) and Part (b), respectively, of Rider GCR.

Franchise Fee Adjustment: Plus an amount for franchise fees calculated in accordance with Rider FF. Rider FF is only applicable to customers inside the corporate limits of any incorporated municipality.

Tax Adjustment: Plus an amount for tax calculated in accordance with Rider TAX.

Surcharges: Plus an amount for surcharges calculated in accordance with the applicable rider(s).

**Curtailement Overpull Fee**

Upon notification by Company of an event of curtailement or interruption of Customer's deliveries, Customer will, for each MMBtu delivered in excess of the stated level of curtailement or interruption, pay Company 200% of the midpoint price for the Katy point listed in *Platts Gas Daily* published for the applicable Gas Day in the table entitled "Daily Price Survey."

**Replacement Index**

In the event the "midpoint" or "common" price for the Katy point listed in *Platts Gas Daily* in the table entitled "Daily Price Survey" is no longer published, Company will calculate the applicable imbalance fees utilizing a daily price index recognized as authoritative by the natural gas industry and most closely approximating the applicable index.

<b>RATE SCHEDULE:</b>	<b>I – INDUSTRIAL SALES</b>	
<b>APPLICABLE TO:</b>	<b>ALL CUSTOMERS IN THE MID-TEX DIVISION EXCEPT THE CITY OF DALLAS AND UNINCORPORATED AREAS</b>	
<b>EFFECTIVE DATE:</b>	<b>Bills Rendered on or after 06/01/2015</b>	<b>PAGE:</b>

**Agreement**

An Agreement for Gas Service may be required.

**Notice**

Service hereunder and the rates for services provided are subject to the orders of regulatory bodies having jurisdiction and to the Company's Tariff for Gas Service.

**Special Conditions**

In order to receive service under Rate I, Customer must have the type of meter required by Company. Customer must pay Company all costs associated with the acquisition and installation of the meter.

<b>RATE SCHEDULE:</b>	<b>R – RESIDENTIAL SALES</b>	
<b>APPLICABLE TO:</b>	<b>ALL CUSTOMERS IN THE MID-TEX DIVISION EXCEPT THE CITY OF DALLAS AND UNINCORPORATED AREAS</b>	
<b>EFFECTIVE DATE:</b>	<b>Bills Rendered on or after 06/01/2015</b>	<b>PAGE:</b>

**Application**

Applicable to Residential Customers for all natural gas provided at one Point of Delivery and measured through one meter.

**Type of Service**

Where service of the type desired by Customer is not already available at the Point of Delivery, additional charges and special contract arrangements between Company and Customer may be required prior to service being furnished.

**Monthly Rate**

Customer's monthly bill will be calculated by adding the following Customer and Ccf charges to the amounts due under the riders listed below:

<b>Charge</b>	<b>Amount</b>
Customer Charge per Bill	\$ 18.60 per month
Rider CEE Surcharge	\$ 0.02 per month <sup>1</sup>
<b>Total Customer Charge</b>	<b>\$ 18.62 per month</b>
Commodity Charge – All <u>Ccf</u>	\$0.09931 per Ccf

Gas Cost Recovery: Plus an amount for gas costs and upstream transportation costs calculated in accordance with Part (a) and Part (b), respectively, of Rider GCR.

Weather Normalization Adjustment: Plus or Minus an amount for weather normalization calculated in accordance with Rider WNA.

Franchise Fee Adjustment: Plus an amount for franchise fees calculated in accordance with Rider FF. Rider FF is only applicable to customers inside the corporate limits of any incorporated municipality.

Tax Adjustment: Plus an amount for tax calculated in accordance with Rider TAX.

Surcharges: Plus an amount for surcharges calculated in accordance with the applicable rider(s).

**Agreement**

An Agreement for Gas Service may be required.

**Notice**

Service hereunder and the rates for services provided are subject to the orders of regulatory bodies having jurisdiction and to the Company's Tariff for Gas Service.

<sup>1</sup>Reference Rider CEE - Conservation And Energy Efficiency as approved in GUD 10170. Surcharge billing effective July 1, 2014.

<b>RATE SCHEDULE:</b>	<b>T – TRANSPORTATION</b>	
<b>APPLICABLE TO:</b>	<b>ALL CUSTOMERS IN THE MID-TEX DIVISION EXCEPT THE CITY OF DALLAS AND UNINCORPORATED AREAS</b>	
<b>EFFECTIVE DATE:</b>	<b>Bills Rendered on or after 06/01/2015</b>	<b>PAGE:</b>

**Application**

Applicable, in the event that Company has entered into a Transportation Agreement, to a customer directly connected to the Atmos Energy Corp., Mid-Tex Division Distribution System (Customer) for the transportation of all natural gas supplied by Customer or Customer's agent at one Point of Delivery for use in Customer's facility.

**Type of Service**

Where service of the type desired by Customer is not already available at the Point of Delivery, additional charges and special contract arrangements between Company and Customer may be required prior to service being furnished.

**Monthly Rate**

Customer's bill will be calculated by adding the following Customer and MMBtu charges to the amounts and quantities due under the riders listed below:

<b>Charge</b>	<b>Amount</b>
Customer Charge per Meter	\$ 700.00 per month
First 0 MMBtu to 1,500 MMBtu	\$ 0.2937 per MMBtu
Next 3,500 MMBtu	\$ 0.2151 per MMBtu
All MMBtu over 5,000 MMBtu	\$ 0.0461 per MMBtu

Upstream Transportation Cost Recovery: Plus an amount for upstream transportation costs in accordance with Part (b) of Rider GCR.

Retention Adjustment: Plus a quantity of gas as calculated in accordance with Rider RA.

Franchise Fee Adjustment: Plus an amount for franchise fees calculated in accordance with Rider FF. Rider FF is only applicable to customers inside the corporate limits of any incorporated municipality.

Tax Adjustment: Plus an amount for tax calculated in accordance with Rider TAX.

Surcharges: Plus an amount for surcharges calculated in accordance with the applicable rider(s).

**Imbalance Fees**

All fees charged to Customer under this Rate Schedule will be charged based on the quantities determined under the applicable Transportation Agreement and quantities will not be aggregated for any Customer with multiple Transportation Agreements for the purposes of such fees.

**Monthly Imbalance Fees**

Customer shall pay Company the greater of (i) \$0.10 per MMBtu, or (ii) 150% of the difference per MMBtu between the highest and lowest "midpoint" price for the Katy point listed in *Platts Gas Daily* in the table entitled "Daily Price Survey" during such month, for the MMBtu of Customer's monthly Cumulative Imbalance, as defined in the applicable Transportation Agreement, at the end of each month that exceeds 10% of Customer's receipt quantities for the month.



<b>RATE SCHEDULE:</b>	<b>T – TRANSPORTATION</b>	
<b>APPLICABLE TO:</b>	<b>ALL CUSTOMERS IN THE MID-TEX DIVISION EXCEPT THE CITY OF DALLAS AND UNINCORPORATED AREAS</b>	
<b>EFFECTIVE DATE:</b>	<b>Bills Rendered on or after 06/01/2015</b>	<b>PAGE:</b>

**Curtailment Overpull Fee**

Upon notification by Company of an event of curtailment or interruption of Customer's deliveries, Customer will, for each MMBtu delivered in excess of the stated level of curtailment or interruption, pay Company 200% of the midpoint price for the Katy point listed in *Platts Gas Daily* published for the applicable Gas Day in the table entitled "Daily Price Survey."

**Replacement Index**

In the event the "midpoint" or "common" price for the Katy point listed in *Platts Gas Daily* in the table entitled "Daily Price Survey" is no longer published, Company will calculate the applicable imbalance fees utilizing a daily price index recognized as authoritative by the natural gas industry and most closely approximating the applicable index.

**Agreement**

A transportation agreement is required.

**Notice**

Service hereunder and the rates for services provided are subject to the orders of regulatory bodies having jurisdiction and to the Company's Tariff for Gas Service.

**Special Conditions**

In order to receive service under Rate T, customer must have the type of meter required by Company. Customer must pay Company all costs associated with the acquisition and installation of the meter.

**MID-TEX DIVISION  
ATMOS ENERGY CORPORATION**

<b>RIDER:</b>	<b>WNA – WEATHER NORMALIZATION ADJUSTMENT</b>	
<b>APPLICABLE TO:</b>	<b>ALL CUSTOMERS IN THE MID-TEX DIVISION EXCEPT THE CITY OF DALLAS AND UNINCORPORATED AREAS</b>	
<b>EFFECTIVE DATE:</b>	<b>Bills Rendered on or after 11/01/2015</b>	<b>PAGE:</b>

Provisions for Adjustment

The Commodity Charge per Ccf (100 cubic feet) for gas service set forth in any Rate Schedules utilized by the cities of the Mid-Tex Division service area for determining normalized winter period revenues shall be adjusted by an amount hereinafter described, which amount is referred to as the "Weather Normalization Adjustment." The Weather Normalization Adjustment shall apply to all temperature sensitive residential and commercial bills based on meters read during the revenue months of November through April. The five regional weather stations are Abilene, Austin, Dallas, Waco, and Wichita Falls.

Computation of Weather Normalization Adjustment

The Weather Normalization Adjustment Factor shall be computed to the nearest one-hundredth cent per Ccf by the following formula:

$$WNAF_i = R_i \frac{(HSF_i \times (NDD-ADD))}{(BL_i + (HSF_i \times ADD))}$$

Where

- $i$  = any particular Rate Schedule or billing classification within any such particular Rate Schedule that contains more than one billing classification
- $WNAF_i$  = Weather Normalization Adjustment Factor for the  $i^{th}$  rate schedule or classification expressed in cents per Ccf
- $R_i$  = Commodity Charge rate of temperature sensitive sales for the  $i^{th}$  schedule or classification.
- $HSF_i$  = heat sensitive factor for the  $i^{th}$  schedule or classification divided by the average bill count in that class
- $NDD$  = billing cycle normal heating degree days calculated as the simple ten-year average of actual heating degree days.
- $ADD$  = billing cycle actual heating degree days.
- $BL_i$  = base load sales for the  $i^{th}$  schedule or classification divided by the average bill count in that class

The Weather Normalization Adjustment for the  $j$ th customer in  $i$ th rate schedule is computed as:

$$WNA_j = WNAF_i \times q_{ij}$$

Where  $q_{ij}$  is the relevant sales quantity for the  $j$ th customer in  $i$ th rate schedule.

**MID-TEX DIVISION  
ATMOS ENERGY CORPORATION**

<b>RIDER:</b>	<b>WNA – WEATHER NORMALIZATION ADJUSTMENT</b>	
<b>APPLICABLE TO:</b>	<b>ALL CUSTOMERS IN THE MID-TEX DIVISION EXCEPT THE CITY OF DALLAS AND UNINCORPORATED AREAS</b>	
<b>EFFECTIVE DATE:</b>	<b>Bills Rendered on or after 11/01/2015</b>	<b>PAGE:</b>

Base Use/Heat Use Factors

Weather Station	<u>Residential</u>		<u>Commercial</u>	
	Base use <u>Ccf</u>	Heat use <u>Ccf/HDD</u>	Base use <u>Ccf</u>	Heat use <u>Ccf/HDD</u>
Abilene	10.22	0.1404	98.80	0.6372
Austin	11.59	0.1443	213.62	0.7922
Dallas	14.12	0.2000	208.11	0.9085
Waco	9.74	0.1387	130.27	0.6351
Wichita Falls	11.79	0.1476	122.35	0.5772

Weather Normalization Adjustment (WNA) Report

On or before June 1 of each year, the company posts on its website at [atmosenergy.com/mtx-wna](http://atmosenergy.com/mtx-wna), in Excel format, a *Weather Normalization Adjustment (WNA) Report* to show how the company calculated its WNAs factor during the preceding winter season. Additionally, on or before June 1 of each year, the company files one hard copy and a Excel version of the *WNA Report* with the Railroad Commission of Texas' Gas Services Division, addressed to the Director of that Division.

**ATMOS ENERGY CORP., MID-TEX DIVISION  
PENSIONS AND RETIREE MEDICAL BENEFITS FOR CITIES APPROVAL  
TEST YEAR ENDING DECEMBER 31, 2014**

Line No.	Description (a)	Shared Services		Mid-Tex Direct			Adjustment Total (g)
		Pension Account Plan ("PAP") (b)	Post-Retirement Medical Plan ("FAS 106") (c)	Pension Account Plan ("PAP") (d)	Supplemental Executive Benefit Plan ("SERP") (e)	Post-Retirement Medical Plan ("FAS 106") (f)	
1	Fiscal Year 2014 Towers Watson Report (excluding Removed Cost Centers)	\$ 6,388,826	\$ 4,542,023	\$ 9,481,670	\$ 165,758	\$ 8,736,645	
2	Allocation to Mid-Tex	46.26%	46.26%	71.70%	100.00%	71.70%	
3	FY14 Towers Watson Benefit Costs (excluding Removed Cost Centers) Allocated to MTX (Ln 1 x Ln 2)	\$ 2,955,304	\$ 2,101,021	\$ 6,798,531	\$ 165,758	\$ 6,264,334	
4	O&M and Capital Allocation Factor	100.00%	100.00%	100.00%	100.00%	100.00%	
5	FY14 Towers Watson Benefit Costs To Approve (excluding Removed Cost Centers) (Ln 3 x Ln 4)	\$ 2,955,304	\$ 2,101,021	\$ 6,798,531	\$ 165,758	\$ 6,264,334	\$ 18,284,949
6							
7							
8	<b>Summary of Costs to Approve:</b>						
9							
10	Total Pension Account Plan ("PAP")	\$ 2,955,304	\$ 2,101,021	\$ 6,798,531		\$ 9,753,835	
11	Total Post-Retirement Medical Plan ("FAS 106")				\$ 6,264,334	\$ 8,365,356	
12	Total Supplemental Executive Retirement Plan ("SERP")				\$ 165,758	\$ 165,758	
13	Total (Ln 10 + Ln 11 + Ln 12)	\$ 2,955,304	\$ 2,101,021	\$ 6,798,531	\$ 165,758	\$ 6,264,334	\$ 18,284,949
14							
15							
16	O&M Expense Factor	95.82%	95.82%	43.03%	21.00%	43.03%	
17							
18	Expense Portion (Ln 13 x Ln 16)	\$ 2,831,859	\$ 2,013,260	\$ 2,925,600	\$ 34,809	\$ 2,695,721	\$ 10,501,250
19							
20	Capital Factor	4.18%	4.18%	56.97%	79.00%	56.97%	
21							
22	Capital Portion (Ln 13 x Ln 20)	\$ 123,445	\$ 87,761	\$ 3,872,930	\$ 130,949	\$ 3,568,614	\$ 7,783,699
23							
24	Total (Ln 18 + Ln 22)	\$ 2,955,304	\$ 2,101,021	\$ 6,798,531	\$ 165,758	\$ 6,264,334	\$ 18,284,949



# City of Killeen

## Legislation Details

---

**File #:** PH-15-021A    **Version:** 1    **Name:** Fleet Services Tools  
**Type:** Resolution/Public Hearing    **Status:** Resolutions  
**File created:** 4/30/2015    **In control:** City Council Workshop  
**On agenda:** 5/19/2015    **Final action:**  
**Title:** Consider a memorandum/resolution to purchase mechanic toolkits for Fleet Services.  
**Sponsors:** Support Services Department  
**Indexes:**  
**Code sections:**  
**Attachments:** [Council Memorandum](#)  
[Quote](#)  
[Tools](#)

Date	Ver.	Action By	Action	Result
------	------	-----------	--------	--------

## **CITY COUNCIL MEMORANDUM**

### **AGENDA ITEM**

### **FLEET SERVICES MECHANIC TOOLKITS**

### **ORIGINATING DEPARTMENT**

### **Support Services**

### **BACKGROUND INFORMATION**

Fleet Services needs to provide the mechanics with effective toolkits and has a unique, resource-efficient, and time-sensitive opportunity to purchase quality toolsets at a significant discount from a national distributor.

The conduct of effective, safe, and timely maintenance operations often hinges on two factors - first, mechanic experience and training and, second, quality facilities and tools. There is no national standard regarding the responsibility to provide mechanic basic toolkits; however, the decision to offload that responsibility to employees can negatively impact an organization's ability to standardize maintenance operations, facilitate training, ensure correct tool-to-task linkages, minimize tool wear and tear, maximize availability of serviceable tools, and enhance employee safety.

The City of Killeen purchases tools for its team of thirteen mechanics. In the past, when replacement tools became difficult to obtain, mechanics brought tools from home in order to complete assigned tasks. Fleet Services eventually purged these tools because of the confusion that mixed ownership creates in terms of accountability; existing toolkits are now a varied mix of older tools from Lowe's (Kobalt), Sears (Craftsman), and Napa (Blackhawk). Replacements are purchased individually and as required. Fleet Services has sustained the use of a common tool room consisting of specialty tools.

### **DISCUSSION/CONCLUSION**

Snap-on is a leading national tool producer and a member of the State of Texas cooperative purchasing network. Research confirms that Snap-on has an excellent reputation and is considered by many professional mechanics to be the gold-standard of tools. Snap-on also uses mobile teams to facilitate timely customer support.

Last year, Snap-on assembled 350 master mechanic toolkits for the federal government; however, the contract was cancelled before the tools were delivered. Each toolkit included SAE (Society of Automotive Engineers) and metric sockets and wrenches, a large securable tool chest, laser cut drawer inserts, and an excellent warranty program. The drawer inserts facilitate accountability, reduce wear and tear, and are normally expensive and purchased separately.

Snap-on recently offered these toolkits for sale to the general public. Fleet Services learned of the offer and explored options with Snap-on's government rep in San Antonio. The optimum solution for Fleet Services given current personnel authorizations is fourteen (14) toolkits, one each for thirteen (13) authorized mechanics and one (1) shared by the three lube techs.

The tools in these kits retail for \$44,061.50 when purchased individually. Snap-on's initial offer was a promotional price of \$16,785 per kit. It then offered an additional 35% discount of \$5,875 if the City of Killeen ordered a minimum of fourteen (14) kits. The total cost per kit would be \$10,910.58.

Of the 350 original kits, less than 50 remain. Snap-on agreed to reserve fourteen sets for the City of Killeen pending council approval.

Support Services contacted a number of organizations to ask how they manage tools. Results varied.

TXDOT provides mechanic toolkits and purchased ~ 350 similar kits from Snap-on.  
Denton provides starter toolkits, if required, and an annual \$650 tool allowance.  
Fort Worth provides starter toolkits, if required, but no tool allowance.  
Austin does not provide toolkits but provides an annual \$1,000 tool allowance.  
Temple does not provide toolkits but provides an annual \$900 tool allowance.  
Georgetown provides toolkits but no tool allowance.  
Johnson Brothers Ford and Toyota of Killeen do not provide toolkits.  
Volkswagen and Mercedes Benz dealers are transitioning to providing toolkits.

The purchase of these toolkits would enable Fleet Services to standardize its tool inventory, ensure correct tool to task linkages, minimize wear and tear, and maximize employee safety. Accountability would be enforced using 10% monthly inventories, 100% inventories on change of hand receipt holders, and loss/damage reimbursement mechanisms. It would also reinforce the progress Fleet Services is making in overall maintenance operations and mechanic recruitment and retention.

## **FISCAL IMPACT**

The cost to purchase fourteen master mechanic toolkits from Snap-on leveraging TXMAS contracts 3-51V-010 and 445-A1 is \$152,748.12. Purchases through a cooperative satisfy the bidding requirements of Texas Local Government Code 271.102.

## **RECOMMENDATION**

Staff recommends the city manager be authorized to take all actions necessary to purchase fourteen master mechanic toolkits from Snap-on for Fleet Services.



# GOVERNMENT Quote

Submit To: Snap-on Industrial  
 A Division of IDSC Holdings, LLC  
 PO BOX 9004  
 Crystal Lake, IL 60039-9004  
  
 (877)740-1900

Number **203288** Date: 4/16/2015  
 Type Quote  
 Customer # 200990890 **Valid Until: 5/16/2015**  
 Cust PO # Final Quote  
 Ship Via UPS GROUND  
 Terms NET 30 DAYS  
 Sales Rep **046969 Russell Blankman, Phone: (210)274-9172**  
 Fax/Mobile (512)233-0852 / (210)274-9172  
 E-mail russell.s.blankman@snapon.com

**Delivery To: 200990890**  
 CITY OF KILLEEN, FLEET SERVICES  
 2003 LITTLE NOLAN RD  
 KILLEEN, TX 76542  
  
 ATTN: Grant Roach

**Bill To: 301060561**  
 KILLEEN, CITY OF  
 CITY OF KILLEEN FLEET SERVICES  
 PO BOX 1329  
 KILLEEN, TX 76540

Item	Description	Origin	SIN	Qty	Unit Price	Total
9400GMBFMBR	BIG SET IN FOAM NSN# - NON-FSS-9400GMBF	UNITED STATES	NON-FSS	14	10,910.58	152,748.12
9400GMSTDAD	STD TOOL ADD-ON FOR 9400METRIC NSN# - NON-FSS-9400GMST	UNITED STATES	NON-FSS	14	0.00	0.00

Tax and freight shown are estimates.

Applicable tax and freight will be charged to the Customers account.

The sale of product is subject to Snap-on Industrial's standard terms and conditions of sale. Placement of an order is Customer's assent to these terms and conditions and Snap-on hereby objects to any additional and/or different terms which may be contained in any Customer forms or other documents. No such additional terms will be of any force or effect.

Items on Snap-on's GSA Federal Supply Schedule (FSS) contract are designated as "105-002" in the SIN column. Items that have either the "NON-FSS" designation or no designation are not available under Snap-on's FSS contract. Such items are being sold outside of the FSS process under other procurement authority, such as Federal Acquisition Regulation (FAR) Subpart 13.2 (micro-purchase) or FAR Subpart 13.3 (simplified acquisition).

The sale of product is subject to Customer meeting Snap-on Industrial's credit approvals. Financing through Snap-on Credit LLC is available on most purchases. Ask your Sales Rep for more information.

**Please reference this quote number on all P.O.s in order to obtain these prices**

<b>Sub Total</b>	<b>\$152,748.12</b>
<b>Tax</b>	<b>\$0.00</b>
<b>Shipping/Handling</b>	<b>\$0.00</b>
<b>Total</b>	<b>\$152,748.12</b>

**STATE OF TEXAS CONTRACT**  
 TXMAS Contract #  
**TXMAS-3-51V-010**  
 Effective 9/20/2010 – 01/31/2016  
 Vendor ID # 1364070294300  
 Federal Tax ID# 13640702943



**MASTER MECHANIC TOOL SET**

# ULTIMATE OFFER

GET THE 613 PIECE  
**9400GMBFMBR**  
METRIC TOOL SET  
FOR **\$16,785** AND  
RECEIVE AN  
ADDITIONAL

# 211 TOOLS FREE

**9400GMBFMBR**  
SET INCLUDES 12 PIECE  
TOOL CONTROL FOAM KIT  
(See back page)

**Snap-on**



# BUY THIS SET . . .

While supplies last, you can purchase this **613 Piece 9400GMBFMBR Master Mechanic Tool Set** complete with Tool Control Foam Kit\* (see back page) for the **GREATLY REDUCED PRICE** of **\$16,785**.



The **9400GMBFMBR Master Mechanic Tool Set** provides a vast array of essential tools to maximize any Technician's potential. Add in the **FREE** fractional accessory tools to the right, and there has never been a better time to expand your capabilities.

\* The tool control foam kit included with the 9400GMBFMBR set holds only the tools from that set and does not include slots for the free products included with this offer.



# GET THESE FREE!

As an added bonus, you will also receive this **211 Piece 9400GMSTDA** tool set with a value of over **\$5,900** for **FREE!**

## 1/4" Drive



110ETMAY - Hex bit 1/16" - 1/4"



110STMY - 6 point, deep 3/16" - 9/16"



110TMY - 6 point, standard 3/16" - 9/16"



1061MTM - 6 point, standard impact 1/4" - 9/16"



106TMUSA - 6 point, universal 1/4" - 9/16"

## 3/8" Drive



208EFAY - Hex bit 1/8" - 3/8"



206AFSA - 6 point, universal 7/16" - 3/4"



205IPF - 6 point, impact universal 7/16" - 3/4"



212SIMFYA - 6 point, deep impact 5/16" - 1"



211SFSY - 6 point, deep 1/4" - 7/8"



212IMFYA - 6 point, standard impact 5/16" - 1"



211FSY - 6 point, standard 1/4" - 7/8"



207SFRH - 6 point, flare nut crowfoot 3/8" - 3/4"

## 1/2" Drive



311IMYA - 6 point, standard impact 3/8" - 1"



313TSYA - 6 point, deep 3/8" - 1 7/8"



307IPLY - 6 point impact flex 9/16" - 1 1/8"



313SIMA - 6 point, deep impact 1/2" - 1 1/4"



313TWYA - 6 point, standard 3/8" - 1 7/8"



NDD900B - Nut driver set 3/16" - 1/2"



OEXS715K - 12 point short combination wrench set 1/4" - 1"



OEX714K - 12 point combination wrench set 3/8" - 1 1/4"



ETB1650A - 1/2" drive electric impact

ECFB960 - Flexible penlight











# City of Killeen

## Legislation Details

---

**File #:** PH-15-021B    **Version:** 1    **Name:** Budget Amendment - Tool Kits for Fleet Services  
**Type:** Ordinance/Public Hearing    **Status:** Public Hearings  
**File created:** 5/13/2015    **In control:** City Council Workshop  
**On agenda:** 5/19/2015    **Final action:**  
**Title:** HOLD a public hearing and consider an ordinance amending the FY 2015 Annual Budget and Plan of Municipal Services of the City of Killeen by increasing a Water and Sewer Fund account by \$152,749 to fund the purchase of 14 tool kits for Fleet Services.  
**Sponsors:** Finance Department, Fleet Services, Support Services Department  
**Indexes:**  
**Code sections:**  
**Attachments:** [Council Memorandum](#)  
[Ordinance](#)

Date	Ver.	Action By	Action	Result
------	------	-----------	--------	--------

## CITY COUNCIL MEMORANDUM

### AGENDA ITEM

### BUDGET AMENDMENT FOR THE PURCHASE OF 14 TOOL KITS FOR FLEET SERVICES

### ORIGINATING DEPARTMENT

Finance

### BACKGROUND INFORMATION

The City has an opportunity to purchase high quality tool kits for Fleet Services staff at a 75% discount. Staff recommends the purchase of 14 tool kits at \$10,910.58 each for a total cost of \$152,748.12. These tool kits come with an excellent warranty and will improve the efficiency, safety, and effectiveness of Fleet Services mechanics. Funding is available from the Water and Sewer Fund Balance.

### DISCUSSION/CONCLUSION

A budget amendment approved by City Council is required to appropriate the funds from Water and Sewer Fund Balance to expend funds for the procurement of the tool kits.

### FISCAL IMPACT

FY 2015 Water and Sewer Fund Balance will be appropriated to provide funding for the purchase of the tool kits for a total of \$152,749.

<i>Account Number</i>	<i>Revised Budget</i>	<i>Budget Increase</i>	<i>Amended Budget</i>
550-2133-460-61-35	\$11,085	\$152,749	\$163,834
<b>Total</b>	<b>\$11,085</b>	<b>\$152,749</b>	<b>\$163,834</b>

### RECOMMENDATION

Staff recommends that the City Council approve this ordinance amending the FY 2015 Municipal Operating budget by \$152,749.



**ORDINANCE \_\_\_\_\_**

**AN ORDINANCE OF THE CITY COUNCIL OF THE CITY OF KILLEEN, TEXAS, AMENDING THE FY 2015 ANNUAL BUDGET AND PLAN OF MUNICIPAL SERVICES OF THE CITY OF KILLEEN BY INCREASING THE WATER AND SEWER FUND EXPENDITURE ACCOUNT BY \$152,749; REPEALING ALL ORDINANCES OR PARTS OF ORDINANCES IN CONFLICT WITH THIS ORDINANCE; PROVIDING A SAVINGS CLAUSE AND ESTABLISHING AN EFFECTIVE DATE.**

**WHEREAS**, a budget for operating the municipal government of the City of Killeen for the Fiscal Year October 1, 2014, to September 30, 2015, has been adopted by City Council in accordance with the City Charter; and

**WHEREAS**, it is the desire of the Killeen City Council to increase the Water and Sewer Fund account by adding funds from fund balance for the purchase of 14 tool kits; and

**WHEREAS**, the need for the additional funds requires a budget amendment;

**NOW THEREFORE, BE IT ORDAINED BY THE CITY COUNCIL OF THE CITY OF KILLEEN:**

**SECTION I.** That Ordinance 14-067 adopting a budget for operating the municipal government of the City of Killeen for the Fiscal Year October 1, 2014, to September 30, 2015, be amended as to the portion of said budget as follows:

<i>Account Number</i>	<i>Revised Budget</i>	<i>Budget Increase</i>	<i>Amended Budget</i>
550-2133-460-61-35	\$11,085	\$152,749	\$163,834

**SECTION II.** That the City Council finds that the public notice and public hearing requirements of Section 56 of the City Charter have been complied with prior to the enactment of this ordinance.

**SECTION III.** That should any section or part of any section or paragraph of this ordinance be declared invalid or unconstitutional for any reason, it shall not invalidate or impair the validity, force or effect of any other section or sections or part of a section or paragraph of this ordinance.

**SECTION IV.** That all ordinances or parts of ordinances in conflict with the provisions of this ordinance are hereby repealed to the extent of such conflict.



**SECTION V.** That this ordinance shall be effective after its passage and publication according to the law.

**PASSED AND APPROVED** at a regular meeting of the City Council of the City of Killeen, Texas, this 26th day of May, 2015, at which meeting a quorum was present, held in accordance with the provisions of V.T.C.A., Government Code, 551.001 *et seq.*

**APPROVED**

\_\_\_\_\_  
Scott Cospers, MAYOR

**ATTEST:**

\_\_\_\_\_  
Dianna Barker, CITY SECRETARY

**APPROVED AS TO FORM:**

\_\_\_\_\_  
Kathryn H. Davis, CITY ATTORNEY